

Electric Service Guidelines

TSN 449260

November 2021



Important Notice Regarding Removal of Oncor Electric Delivery Company LLC Meters to Perform Work on Customer's Premise

Effective October 15, 2013, as provided for in the Oncor Tariff for Retail Delivery Service approved by the Public Utility Commission of Texas (PUC), unauthorized removal of an Oncor meter, which includes any work on the customer's equipment that would require cutting the seal and removal of the meter, will result in a charge to the customer of \$19.20. Additional charges may also be applied if tampering is determined to have occurred.

To ensure that a customer is not charged these fees as a result of work being performed, prior authorization must be obtained by following the steps below BEFORE removing self-contained meters (only Oncor is authorized to remove 480 volt self-contained meters) and disconnecting power at a customer's premise.*

Call Oncor at 1.800.518.2374 BEFORE removing an Oncor self-contained meter and provide the following information:

- Electrical Contractor's Company name
- Contact phone number for clarifying information
- Contact person's name at Electrical Contractor Company
- Address where the work is to be done (if rural, provide directions)
- City
- Work to be done
- Will work require an electrical inspection? (Yes / No)
- Date meter will be pulled
- Date meter will be replaced

Upon receipt of the above notice, Oncor will schedule a trip to the customer's premise after the self-contained meter has been replaced, to inspect and reseal the meter.

If work is not completed on the date planned, customer or electrician must contact Oncor to avoid a charge being assessed.

The number above is answered between 8:00 a.m. and 7:00 p.m. M-F. For after-hours work, please leave the required information on the voicemail.

Failure to follow this process will result in the customer being charged, at a minimum \$19.20. Additionally, if the Oncor meter (or the customer's meter base) is determined to have been compromised and/or damaged, other charges may be applied.

If you have questions or need additional information, please refer to the Oncor.com website or call 1.800.518.2374

*If there is a locking mechanism (i.e., such as a lock or locking bar), contact Oncor at 1.800.518.2374 to schedule the removal of the locking mechanism prior to any work being conducted. Only Oncor may remove the locks. Please provide one business day notice for this type of work to be performed.

CONTENTS

FOREWORD	Page 4
SECTION 100	
100.01 General Information Definitions.....	Page 5-9
100.02 Codes Governing Electrical Installations Information.....	Page 10
100.03 Company Service Area Information.....	Page 11
100.04 Security and Safety Information.....	Page 12
100.05 Standard Delivery Service Information.....	Page 13-14
SECTION 200	
Clearances.....	Page 15-22
SECTION 300	
Overhead Service.....	Page 23-33
SECTION 400	
Underground Service.....	Page 34-41
SECTION 500	
Metering and Associated Equipment.....	Page 42-72
SECTION 600	
Temporary Service.....	Page 73-75
SECTION 700	
Distributed Generation	Page 76-79
APPENDIX A	
Two Hole Compression Lugs for Terminal Connections.....	Page 80
APPENDIX B	
One Hole Compression Lugs for Submersible Mole Connections.....	Page 81
APPENDIX C	
Primary Metering Equipment Connection.....	Page 82-85

FOREWORD

This booklet is issued by Oncor Electric Delivery Company LLC (Company) for use by Customers and their agents. These Electric Service Guidelines supersede all prior issues of the Electric Service Guidelines issued by Oncor and are effective with all construction commencing on or after November 2021.

This booklet should be used as a guide in planning the installation of electrical equipment and methods for interconnection of electrical power and energy with the electrical delivery system of Company.

If service methods other than the examples discussed in this booklet are required, the Customer is to obtain written Company approval prior to letting bids and installing equipment.

Where local inspection authority is not involved, equipment should be installed in accordance with the latest edition of the National Electrical Code or Company specifications when the Company specifications exceed those of the National Electrical Code.

The information presented herein will be revised periodically to reflect changes which may develop. It is the Customer's responsibility for obtaining the latest revision.

**For New Customers Requesting Service, please complete the New Serve Questionnaire found at:
www.oncor.com/SitePages/NewConstruction.aspx**

**For underground utility locating service:
[Call 811 before you dig.](tel:811)**

For information about Solar, Battery Storage, or other forms of Customer Owned Distributed Generation (DG) please email DG@ONCOR.com OR visiting www.oncor.com/sitepages/RenewableEnergy.aspx

SECTION 100

GENERAL INFORMATION DEFINITIONS

100.01 DEFINITIONS

- 100.01.01 **Company**
Oncor Electric Delivery Company LLC and its officers, agents, employees, successors, and assigns.
- 100.01.02 **Company Conductor/Cable**
Oncor Electric Delivery Company LLC and its officers, agents, employees, successors, and assigned owned cable and/or conductor. (i.e. primary, secondary, service lateral)
- 100.01.03 **Connected Load**
The combined electrical requirement (i.e., the sum of the capacities and/or ratings) of all motors and other electric power consuming devices installed on the Customer's premises.
- 100.01.04 **Current Transformer (CT)**
A transformer used in metering applications which reduces, by a definite ratio, the value of primary current to a value usable by the meter.
- 100.01.05 **CT Enclosure (also known as CT Can)**
See instrument transformer enclosure.
- 100.01.06 **CT Socket**
A meter socket used only with external instrument transformers.
- 100.01.07 **Customer**
An end-use customer who purchases electric power and energy and ultimately consumes it. When used in the context of construction services, the term Customer also includes property owners, builders, developers, contractors, governmental entities, or any other organization, entity, or individual that is not a Competitive Retailer making a request for such services to the Company.
- 100.01.08 **Delivery Service**
The service performed by Company for the delivery of electric power and energy. Delivery Service comprises delivery system services and discretionary services.
- 100.01.09 **Demand**
The rate at which electric energy is used at any instant or averaged over any designated period of time and which is measured in kW or kVA.
- 100.01.10 **Demand Interval**
The specified interval of time on which a demand measurement is based. The Company demand interval is normally 15 minutes.
- 100.01.11 **Energy**
The measure of how much electric power is provided over time for doing work. The electrical unit is the watt-hour, or kilowatt-hour.
- 100.01.12 **Emergency Disconnect**
An exterior disconnect installed on one and two family dwellings. To be located closely adjacent to the meter base. To be used by first responders in the event of a natural disaster, fire, flooding and the like.

GENERAL INFORMATION DEFINITIONS (cont'd)

- 100.01.13 **Facility Extension Agreement**
The service agreement that must be executed by Company and Customer requesting certain construction services before Company can provide such construction services to the requesting entity.
- 100.01.14 **Good Utility Practice**
The term will have the meaning ascribed thereto in PUC Substantive Rules, Section 25.5, Definitions, or its successor.
- 100.01.15 **Grounding Electrode**
A conducting object through which a direct connection to Earth is established. The only Company approved grounding electrode is the Ground Rod. Ufer grounds will not be accepted.
- 100.01.16 **Ground Rod**
The only Company approved grounding electrode allowed for grounding purposes. Ground Rod shall be made of copper clad steel, 8ft in length and, at least .625 inches in diameter.
- 100.01.17 **Generator Transfer Switch**
A customer generator transfer switch is to be installed on the load side of the meter base. It is under no circumstances that a generator transfer switch be integrated or placed in series with the meter and the base.
- 100.01.18 **Inspection Authority**
The governing bodies having jurisdiction over inspection of Customer installations and equipment and oversight of NEC Compliance.
- 100.01.19 **Interconnection Agreement**
The interconnection agreement sets forth the contractual conditions under which a Company and Customer agree that one or more facilities (DG) may be interconnected with the Company utility system.
- 100.01.20 **Instrument Transformer (IT)**
Current transformers and voltage transformers are collectively called instrument transformers and are used for metering electric service.
- 100.01.21 **Instrument Transformer (IT) Enclosure (also known as CT Can or CT Enclosure)**
A metal cabinet which houses the Company's instrument transformers when a transocket is not feasible.
- 100.01.22 **Maximum Available Fault Current**
The amount of current that will flow due to a direct short circuit from one conductor to ground or from one conductor to another.
- 100.01.23 **Meter**
A device or devices for measuring the amount of electric power and energy delivered to a particular location.

GENERAL INFORMATION DEFINITIONS (cont'd)

- 100.01.24 **Meter/Main Combination**
The meter socket breaker combination unit can serve as an all in one service entrance equipment for single family and duplex residential service customers provided it meets the guidelines of the Authority Having Jurisdiction (AHJ). It contains the ringless meter socket as well as the breaker(s). This enclosure has completely separate utility and customer compartments. It can meet the NEC Code 230.85 regarding outdoor emergency disconnects. See Table 5-C pg 58 for reference.
- 100.01.25 **Meter Pack**
A single enclosure that allows for multiple meters. Before purchasing a meter pack, please contact your Oncor Representative for approval.
- 100.01.26 **Meter Socket**
A receptacle of weatherproof construction used for mounting a socket type meter. Customer shall permanently mark each meter socket at multi-meter locations before a meter can be set. See 500.11 pg 48 for reference.
- 100.01.27 **Non-Standard Facilities**
May include but are not limited to a two-way feed, automatic and manual transfer switches, Delivery Service through more than one Point of Delivery, redundant facilities, facilities in excess of those normally required for Delivery Service, or facilities necessary to provide Delivery Service at a non-standard voltage.
- 100.01.28 **On-Site Distributed Generation (DG)**
An electrical generating facility located at a Customer's point of delivery (point of common coupling) of 10 MW or less and connected at a voltage less than 60 kV which may be connected in parallel operation to the utility system.
- 100.01.29 **Parallel Operation**
The operation of on-site distributed generation while the Customer is connected to the Company's utility system.
- 100.01.30 **Point of Common Coupling (PCC)**
The point where the electrical conductors of the Company utility system are connected to the Customer's conductors and where any transfer of electric power between the Customer and the utility system takes place, such as switchgear near the meter.
- 100.01.31 **Point of Delivery (POD, Service Point)**
The Point at which electric power and energy leaves the Company delivery system. The Company POD is the same as the NEC Service Point. See NEC Handbook Article 100, Exhibit 100.15 and Exhibit 100.16 and Service Point.
- 100.01.32 **Raceway**
Tubular or rectangular channel or conduit for containing electrical conductors, which may be exposed, buried beneath the surface of the earth, or encased in a building or structure.
- 100.01.33 **Secondary Service**
Non-residential delivery service at any one of Company's standard service voltages listed in 100.05.02, page 13.
- 100.01.34 **Service Agreement**
Any commission approved agreement between Company and Customer which sets forth certain information, terms, obligations and/or conditions of delivery service pursuant to the provisions of the Tariff for Retail Delivery Service.

GENERAL INFORMATION DEFINITIONS (cont'd)

- 100.01.35 **Service Availability Statement**
A statement from the Company designating the acceptable location of the Customer's service entrance conductors, the proper location of meters and metering equipment, the type of service available or which will be made available to the specific location under consideration, and the capacity of the service to be provided.
- 100.01.36 **Service Disconnect**
An appropriate means of disconnecting a service location from the Companies facilities and discontinuing the flow of energy and power. Disconnect must be able to be locked in the "Open" position.
- 100.01.37 **Service Drop**
Overhead conductors that extend from Company's overhead delivery system to the point of delivery (POD) where connection is made to Customer's electrical installation.
- 100.01.38 **Service Enclosure**
A connection enclosure specified, provided, owned and locked/sealed by the Company. Company provides the Service Enclosure to the Customer and it is installed by Customer for the purpose of connecting the service lateral to Customer's electrical installation. Typically installed on the exterior of a structure. See 500.08, page 48.
- 100.01.39 **Service Entrance Conductors**
Conductors provided by Customer extending from Customer's electrical equipment to the point of delivery (POD) where connection is made.
- 100.01.40 **Service Equipment**
The necessary equipment, usually consisting of (a) circuit breaker(s) or switch(es) and fuse(s) and their accessories, connected to the load end of service conductors to a building or other structure, or an otherwise designated area, and intended to constitute the main control and cutoff of the supply.
- 100.01.41 **Service Lateral**
Conductors, usually underground but sometimes in raceway above ground, that extend from Company's delivery system to the point of delivery or from Customer's electrical installation to the point of delivery.
- 100.01.42 **Service Point**
See 100.01.31, page 7 Point of Delivery; Reference NEC Handbook Article 100, Exhibit 100.15 and Exhibit 100.16 and Service Point.
- 100.01.43 **Secondary Enclosure**
A pad mounted connection enclosure specified, installed, owned and locked/sealed by Company, located adjacent to Company transformer used to connect Customer's service conductors that are in excess in number and/or size, and cannot normally be accommodated by transformer. A secondary enclosure and its pad, conduits, trenching and secondary conductors from transformer to the secondary enclosure and are owned and installed by Company. A Customer payment is typically required for a secondary Enclosure installation. See 500.09, page 48.
- 100.01.44 **Secondary Pedestal**
A single phase secondary pedestal is a free standing HDPE connection enclosure. It will accommodate 6 connections of #4 - 500 kcmil conductor per connector. Use in lieu of secondary/service handholes.

GENERAL INFORMATION DEFINITIONS (cont'd)

- 100.01.45 **Tariff for Retail Delivery Service**
The document filed with, and approved by, the PUC pursuant to which Company provides delivery service. It is comprised of Rate Schedules, Riders, and Service Rules and Regulations. The Service Rules and Regulations include definitions, terms and conditions, policies, and Service Agreements.
- 100.01.46 **Transocket**
A metal enclosure which includes instrument transformers and meter socket.
- 100.01.47 **Ufer Ground**
A grounding method to foundation steel which is not recognized as an approved grounding electrode. A grounding method to foundation steel which the company does not recognize as an approved grounding electrode for metering equipment. Used by the customer for their service entrance facilities only.
- 100.01.48 **Visible Lockable Labeled AC Disconnect (VLLD)**
A manual disconnect device that has a visual break that is appropriate to the voltage level, be accessible to utility personnel, and capable of being locked in the open position.
- 100.01.49 **Voltage Transformer (VT, also known as PT-Potential Transformer)**
A transformer used in metering applications which reduces, by a definite ratio, the value of primary voltage to a value usable by the meter.

CODES GOVERNING ELECTRICAL INSTALLATIONS INFORMATION

100.02 CODES GOVERNING ELECTRICAL INSTALLATIONS

100.02.01 National Electrical Safety Code

The National Electrical Safety Code (NESC) is the code the Company follows in design and construction of electric supply lines whether overhead or underground.

100.02.02 National Electrical Code

The National Electrical Code (NEC) is published by the National Fire Protection Association (NFPA). The current edition of the NEC is the code that electrical contractors follow for wiring Customer's electrical installations.

100.02.03 Inspection and Approval of Customer's Electrical Installation

In those locations where an ordinance requires the Customer to obtain a certificate of inspection and acceptance or a permit, Customer will obtain all necessary permits and certificates of inspection covering its electrical installation. Company requires customer to meet all code and Company requirements pertaining to corresponding installation. Company will not interconnect its distribution facilities with Customer's electrical installation until Company receives notification of approval of Customer's electrical installation by the proper authority. Company does not assume any duty of inspecting Customer's lines, wires, switches, ground rods, or other equipment. Without limiting the foregoing sentence, Company may decline to interconnect its delivery system facilities with any of Customer's electrical installation that is known to be hazardous under applicable codes or that is of such character that satisfactory delivery service cannot be provided consistent with good utility practice, or where a known dangerous condition exists and for as long as it exists. **The providing of delivery service by Company does not indicate that Company has inspected Customer's electrical installation and pronounced it safe or adequate. If service methods other than the examples outlined in this booklet are required, the Customer is to obtain written Company approval prior to letting bids or installing equipment.**

COMPANY SERVICE AREA INFORMATION

100.03 COMPANY SERVICE AREA

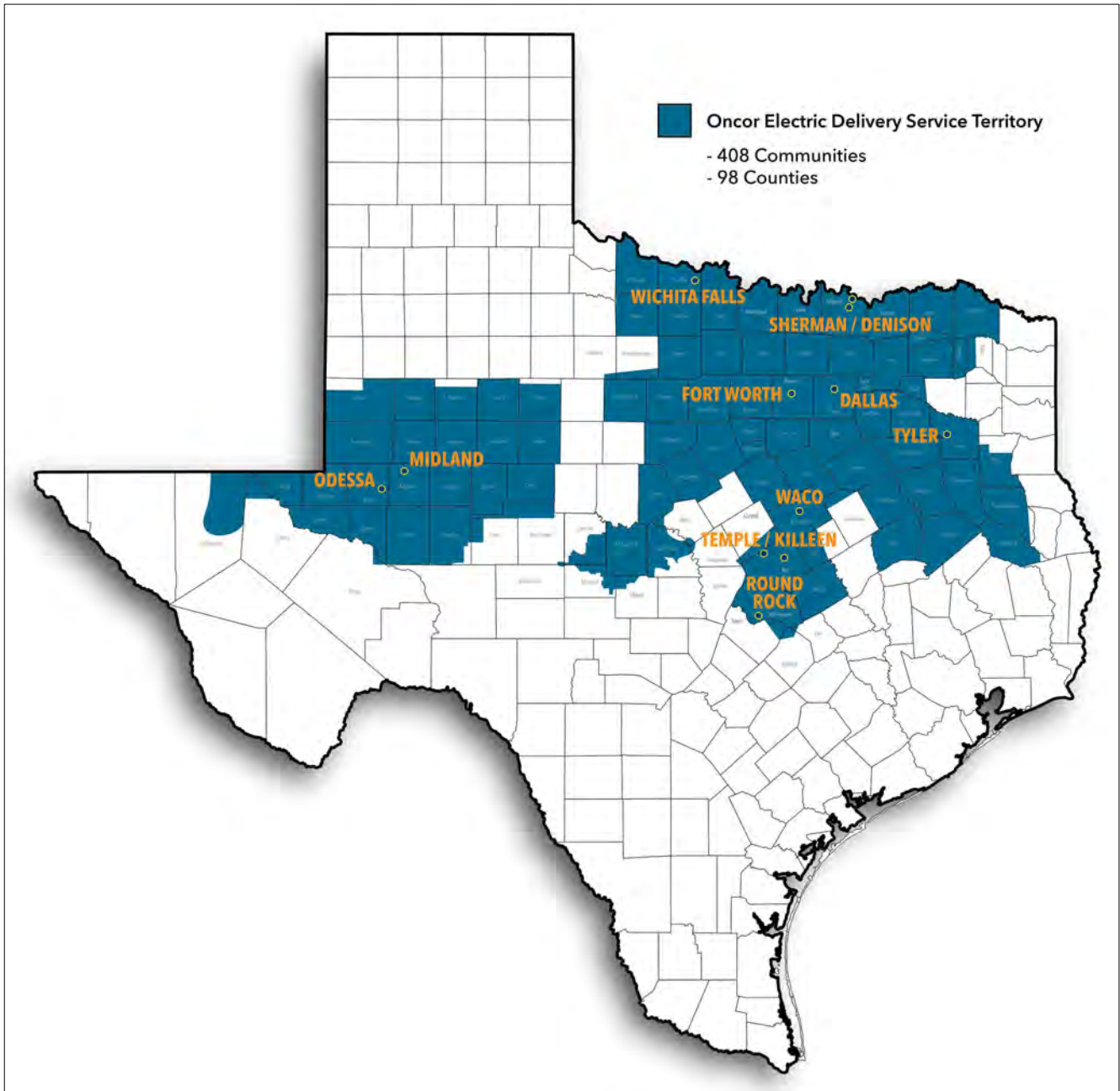

SECURITY AND SAFETY INFORMATION

100.04 SECURITY AND SAFETY

100.04.01 Radio and Television Antennas

Antennas for radio, radio transmitter (including citizen band or amateur), or televisions shall not be erected over or under Company's overhead electric lines, nor shall they be attached to Company's poles or other equipment. Antennas should be located as far as practicable from Company's lines and in a place where they may not accidentally fall into energized wires. To do otherwise may result in serious accidents, damage to property or poor radio or television reception. The attachment of antenna guying systems to poles carrying Company's conductors is prohibited. Such attachments will be removed upon discovery by Company.

100.04.02 Attachments to Company Facilities

Company does not permit any unlicensed attachments (such as wires, ropes, signs, banners, metering equipment, radio equipment, lightning arresters, alarms, etc.) to Company facilities by others except when authorized in writing by Company. Licensed attachments must comply with all requirements set forth by Company. License agreements do not allow meter equipment to be installed on Company poles if licensee utilization equipment is not on the same Company pole. See 500.04, page 44. **Company may without notice and without liability remove unauthorized attachments to Company facilities.** For more information, please contact Oncor's Joint Use department at 1.888.313.4747.

100.04.03 Company's Locks or Seals

It is standard practice by Company to install locks or seals on all meters, service enclosures, service disconnects, pad mounted transformers, pad mounted switchgear, unmetered service wireways, or other equipment. **Only Company agents and authorized persons shall remove a seal or lock.** See 500.02, page 43. See "Important Notice Regarding Removal of Oncor Meters to Perform work on Customer's Premise" printed inside front cover of this booklet.

100.04.04 Tampering

Tampering with Company equipment or using any method which permits the flow of unmetered energy to a premise violates the laws of the State of Texas and may lead to disconnection of service, prosecution, or both. Company shall not be liable to Customer for any injuries or damages that result from such tampering.

STANDARD DELIVERY SERVICE INFORMATION

100.05 STANDARD DELIVERY SERVICE

100.05.01 General

Company provides delivery service at the Company's standard voltages in accordance with Company's facilities extension policy, and not all standard voltages are available at every location. If Customer requests a voltage which is non-standard or not available for a specific load or location, such voltage may be provided by Company at the Company's discretion and at the expense of the requesting party. Company does not guarantee that facilities providing non-standard service (e.g., transformers) are readily available and extended outages may result.

100.05.02 Standard Secondary Voltages

Single-Phase		Three-Phase	
Voltage	Connection	Voltage	Connection
120	2W	120/208	4W,Y (OH) & (UG)
120/240	3W	120/240	4W, Δ (OH)
240	2W	240	3W, Δ (OH)
240/480	3W	240/480	4W, Δ (OH)
480	2W	277/480	4W,Y (OH) & (UG)
2400*	2W	480	3W, Δ (OH)
		2400*	3W, Δ (OH)
		2400/4160*	4W,Y (OH) & (UG)
		4160*	3W,Y (OH)

* See Company for metering requirements for these voltages.

Notes:

1. All four-wire services require three phase conductors and an NEC compliant neutral.
2. Overhead service is designated by (OH).
3. Underground service is designated by (UG).

100.05.03 Request for Underground Three-Wire, Three-Phase Service (Non-Standard)

The use of three-wire, three-phase service at 240 V, 480 V and 2400 V, shall be grounded unless the Customer requests, in writing, that the service be ungrounded (i.e. one service conductor is grounded at the distribution transformer and at the Customer's premises grounding electrode system). See 500.06.07, page 46 for meter sockets used on ungrounded services. Contact Company representative for details. The use of three-wire, three-phase service at 240 V and 480 V is only available from overhead transformers. The use of three-wire, three-phase service at 2400 V is available from overhead and pad mounted transformers in limited size ranges. New and existing Customers adding load should check with the appropriate Company representative on availability of service at 2400 V from overhead or pad mounted transformers.

100.05.04 120/208 V, Single-Phase, Three-Wire Network Service (Non-Standard)

When and if available, Secondary Service Customers requesting 120/208 V, single-phase, three-wire service from Company Network Distribution systems in downtown Dallas and downtown Fort Worth are limited to service entrance capacity of 60 amperes. See 100.05.01 and Figure 5-1, page 71. For services greater than 60 amperes, the Customer must wire for full four-wire, wye service.

STANDARD DELIVERY SERVICE INFORMATION (cont'd)

- 100.05.05 **Non-Network Secondary Service Customers**
Requesting 120/208 V, single-phase, three-wire service from Company distribution systems may be limited based upon the existing Company facilities that must be reviewed for each location requested. If Customer load is greater than 200 amperes, Customer must wire for full four-wire, wye service. This applies to both overhead and underground services. Refer to 100.05.01, page 13 and Figure 5-I, page 71.
- 100.05.06 **Mixed Use Customer Facilities**
Three-phase service for mixed use customer facilities (i.e. residential and commercial) shall be treated as Secondary Service. The point of delivery for such services shall be as specified in Drawings on pages 40-56.
- 100.05.07 **Easements, Rights-of-Way, Suitable Space, and Point of Delivery (POD) Requirements**
Customer's electrical installation must be arranged so that the location of the point of delivery allows Company to provide safe and reliable delivery service, taking into consideration the location of existing Company facilities and construction needed to connect Customer's electric installation to Company system. Customer must grant or secure for Company, at Customer's expense, any rights-of-way or easements on property owned or controlled by Customer necessary for Company to install delivery system facilities for the sole purpose of delivering electric power and energy to Customer. Customer must provide, without cost to Company, suitable space on Customer's premises for the installation of delivery system facilities necessary to deliver electric power and energy to Customer and for installation of Company's metering equipment and the meter. Customer shall clearly mark the final location of the service conduit riser where the meter will be set. This location must allow for safe and reliable delivery of service. Company may inspect Customer provided space before installing electric facilities.
- Any change from the Company designated point of delivery (POD) is subject to payment by customer based on any added costs to reach the new designated point.
- To obtain standards on suitable space, Easement and/or Right-of-Way requirements, contact Company Representative.
- 100.05.08 **Loads Exceeding 3000 Amperes**
Standard delivery service at 600 volts and less may be limited to 3000 amperes of load through a single Customer owned service entrance. Company may require loads exceeding 3000 amperes to be served with two or more adjacent services at one POD with totalized metering and an Automated Throw-over Switch on the customers secondary.
- 100.05.09 **Customer's Electrical Load and Parallel Operation**
Customer must take reasonable actions to control the use of electric power and energy so that Customer's electrical load at the point of delivery is in reasonable balance and Customer's parallel operation meets the contractual conditions of the interconnection agreement.
- 100.05.10 **Sensitive Equipment Protection**
Customers planning the installation of electric equipment such as computers, communication equipment, electronic control devices, motors, etc., the performance of which may be adversely affected by voltage fluctuations, distorted 60 hertz wave forms, or single-phase events are responsible for providing and installing the necessary facilities, including protective equipment, to limit these adverse effects.
- 100.05.11 **Three-Phase Service Four-Wire, 120/240 V**
Service at 120/240 Volt three-phase, Four-wire delta is available from overhead transformers. Availability of this service voltage from pad mounted transformers is very limited. New Customers or existing Customers adding load should check with Company regarding availability of four-wire, 120/240 V, three-phase service from a pad mount transformer.

SECTION 200

CLEARANCES

200.01 Texas Law & OSHA Regulations

To ensure safety and the protection of the public, Chapter 752 of the Texas Health and Safety Code makes it unlawful for unauthorized persons to move or be placed or bring any part of a tool, equipment, machine, or material within proximity of live overhead high voltage lines. OSHA Regulations also restrict the activities of unauthorized persons. See back cover for more details. Contractors and owners are legally responsible for the safety of construction workers under this law. This law carries both criminal and civil liability. The Oncor document **Safety Smart** provides additional information and may be found at website: oncor.com/EN/Pages/SafetySmart.aspx. For lines to be turned off, moved, or other arrangements, call Oncor at 1.888.313.6862

200.02 Local Codes

Some local Electrical Codes require structures to be located a safe distance away from live overhead high voltage lines as defined by the National Electrical Safety Code.

200.03 Clearances for Service Drop

See Figure 2-A, page 16.

200.04 Clearances of Swimming Pools from Overhead Facilities

Before installation of a pool, contact Company to review clearances to overhead facilities. See Figure 2-B, pages 17-18 and Table 2-B, page 19.

200.05 Clearances of Swimming Pools from Underground Facilities

Before installation of a pool, contact Company to review clearances to underground facilities. See Figure 2-C, page 20.

200.06 Clearances of Pad Mounted Transformers from Buildings

pad mounted transformers shall be installed to meet the spatial separations to buildings set forth in Figure 2-D, page 21. No transformers shall be installed within the drip line of a building unless installed in a transformer vault meeting the requirements of Article 450 of the National Electrical Code.

200.07 Screening Clearances around Pad Mounted Equipment

See Figure 2-E, page 22.

200.08 Suitable Space

The required amount of cleared space after vegetation and other obstructions have been removed in order to permanently and securely have stable access to install, operate, maintain replace Company facilities. Contact Company Representative for details.

CLEARANCES OF SERVICE DROP

FIGURE 2-A

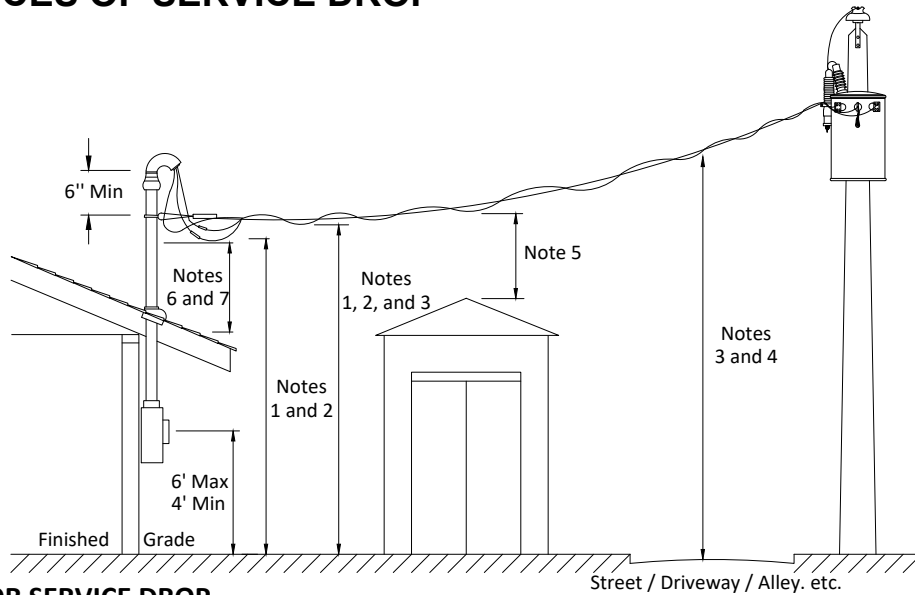

CLEARANCES FOR SERVICE DROP

Clearances shall be maintained under all varying conditions of wind, temperature and ice loading. Allowance should be made for change in conductor sag due to varying temperature, wind and ice loading on the conductor. See Table 3-C, page 27 for minimum service attachment height.

Vertical Clearances		Single-Phase 120/240 208Y (ft)	240D 480Y (ft)	480D Single-Phase 480 (ft)
Notes:				
1.	Over spaces and ways subject to pedestrians or restricted vehicular traffic not exceeding 8 feet in height (see Exceptions below)		12	
2.	Residential Driveway (see Exceptions below)		16	
3.	Alleys, commercial and apartment driveways, parking lots, and other areas subject to truck traffic.		16	
4.	Streets, highways, county, or other public roads		22	
5.	Roof not readily accessible by means of permanent ladder, doorway, ramp, or stairway (service not attached to building, i.e. passing over).*		3.5	
6.	Roof within 6 feet of mast where mast is within 4 feet of nearest roof edge		1.5	
7.	Over roof of building service is attached to and roof is not readily accessible. *		3	

EXCEPTIONS: listed below are related to Vertical Clearance Notes 1 & 2 for Insulated cables and where height of residential building does not permit above values. Prior approval by Company representative is required.

Exception 1	Over spaces and ways for residential service drops subject to pedestrians and restricted traffic not exceeding 8 feet in height.	10	10.5	12
Exception 2	Over residential driveways only			
	· Service conductor	12	12.5	16
	· Drip loops	10	10.5	16

*A roof, balcony, or area is considered readily accessible to pedestrians if it can be casually accessed through a doorway, ramp, window, stairway, or permanently mounted ladder by a person on foot who neither exerts extraordinary physical effort nor employs tools or devices to gain entry. A permanently mounted ladder is not considered a means of access if its bottom rung is 8 feet or more from the ground or other permanently installed accessible surface.

HORIZONTAL CLEARANCES

Service drop conductors attached to a building shall not pass closer than 3 feet from windows, wall projections, fire escapes, balconies or similar locations.*

CLEARANCES OF SWIMMING POOLS FROM OVERHEAD FACILITIES

FIGURE 2-B

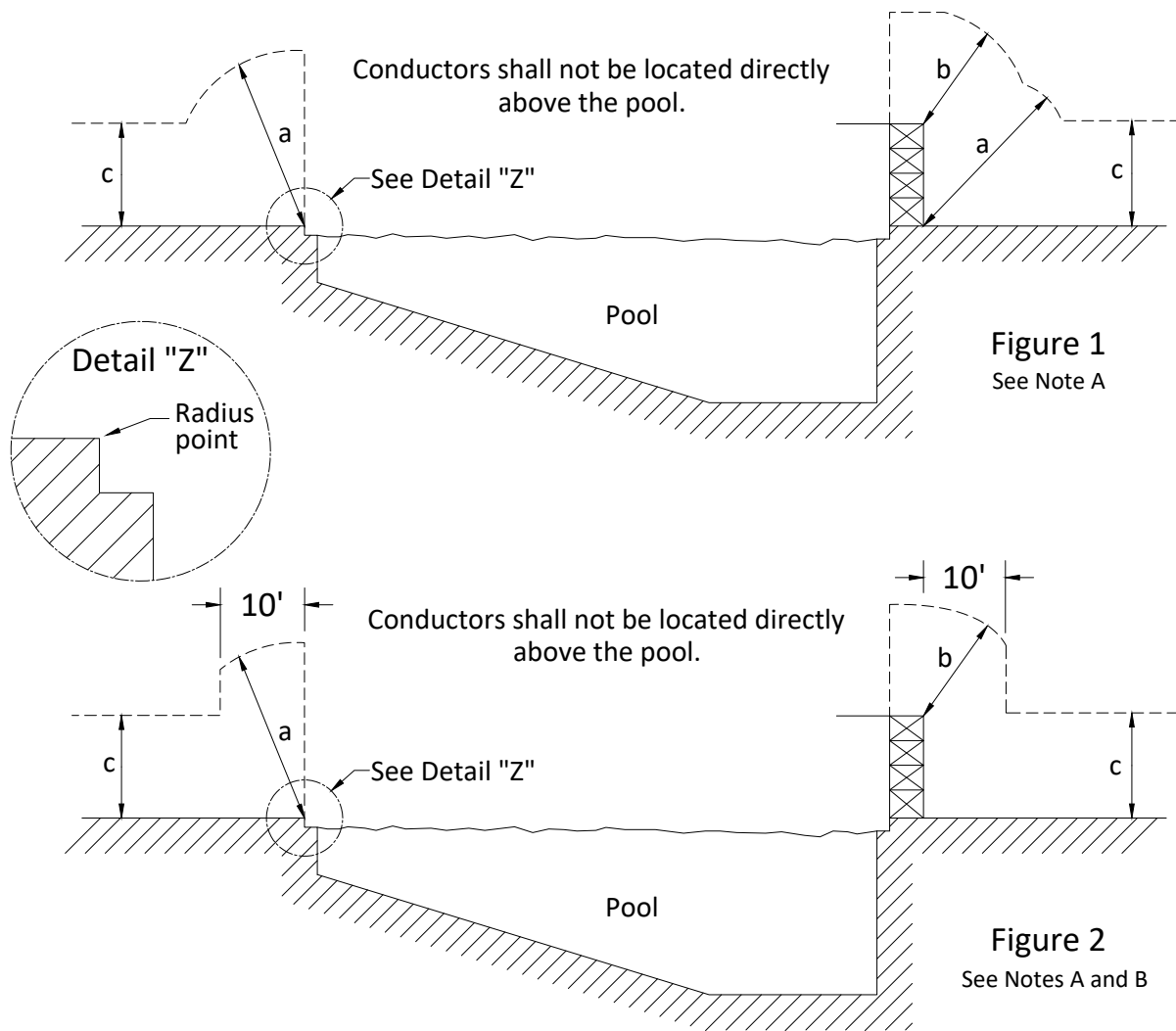

Notes:

- A. Dimensions for "a", "b", and "c" shown above are defined by table on Page 19.
- B. Figure 2 shall be applied ONLY to:
 - Overhead Guys;
 - Neutral Conductor;
 - Cabled Conductor ≤ 750 V Phase to Ground

CLEARANCES OF SWIMMING POOLS FROM OVERHEAD FACILITIES (cont'd)

FIGURE 2-B

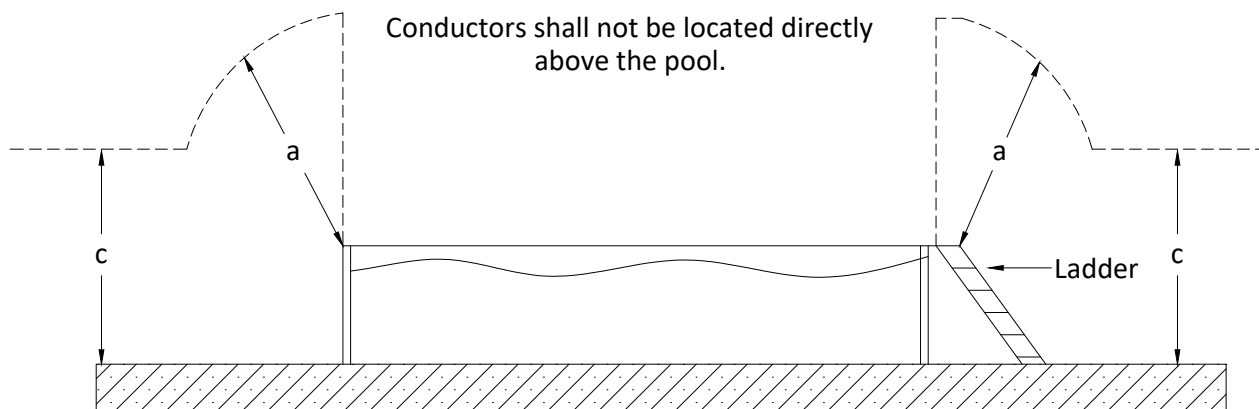

Above ground swimming pool without a deck. Clearances maintained from the highest point of the installation.

Figure 3

See Notes A and C

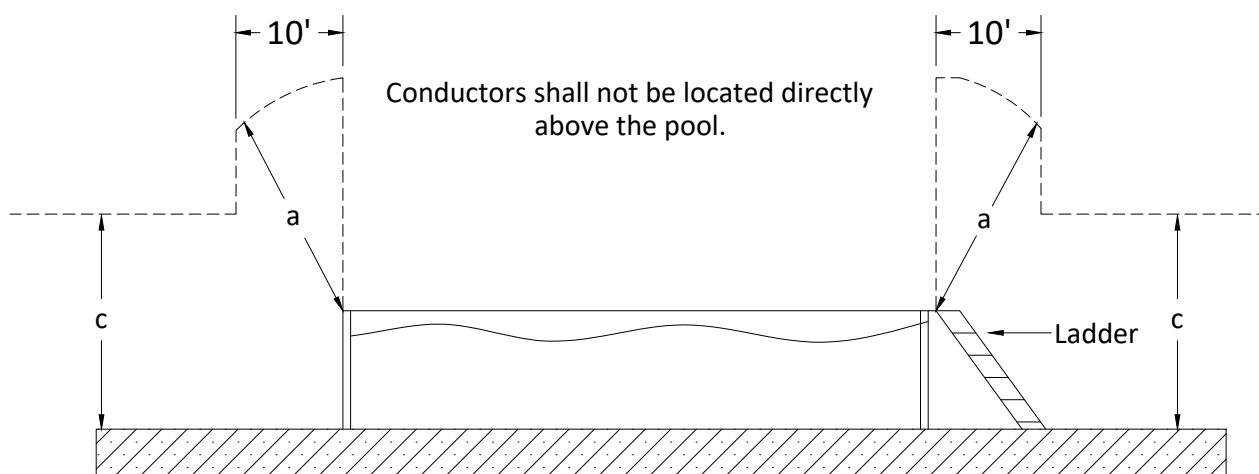

Above ground swimming pool without a deck. Clearances maintained from the highest point of the installation.

Figure 4

See Notes A, B, and C

Notes:

- A. Dimensions for "a" and "c" shown above are defined by table on Page 19.
- B. Figure 4 shall be applied ONLY to:
 - Overhead Guys;
 - Neutral Conductor;
 - Cabled Conductor \leq 750 V Phase to Ground
- C. Proper respective clearances must be maintained if a diving platform, tower, water slide, or other fixed, pool-related structure exists.

CLEARANCES OF SWIMMING POOLS FROM OVERHEAD FACILITIES (cont'd)

TABLE 2-B

The table below contains clearance values based upon the requirements of the National Electrical Safety Code with allowances for worst case conditions. Actual clearance requirements vary with conductor size and type, ambient air temperature, and other factors. The values shown in the table are meant to be a guideline. **When clearances are less than indicated in the table, the Customer should contact Company for exact requirements based on field conditions.**

Please Note: **Wires, conductors, cables, or unguarded rigid live parts shall not pass over a swimming pool.**

	Requirements	Overhead Guy or Neutral (ft)	Bundled or Cabled Secondary or Service (ft)	Open Wire Secondary or Service (ft)	Pole Line or Primary Conductor (ft)
a.	Clearance in any direction from water level, edge of pool, base of diving platform, or anchored raft.	27	27.5	28	30
b.	Clearance in any direction to diving platform, tower, water slide or other fixed, pool related structure.	19	19.5	20	22
c.	Vertical clearance over adjacent land which is driveways, parking lots, and alleys subject to truck traffic (any vehicle exceeding 8 feet in height).	20.5	21	21.5	23.5
d.	Vertical clearance over adjacent land which is spaces and ways subject to pedestrians or restricted traffic only. *	14.5	17	17.5	19.5
e.	These clearances do not apply to overhead guys, neutral conductors and cabled conductor \leq 750 volts when these facilities are 10 feet or more horizontally from the edge of the pool, diving platform, diving tower, water slide, or other fixed, pool related structure.	10	-	-	-

CLEARANCE OF SWIMMING POOLS FROM UNDERGROUND FACILITIES

FIGURE 2-C

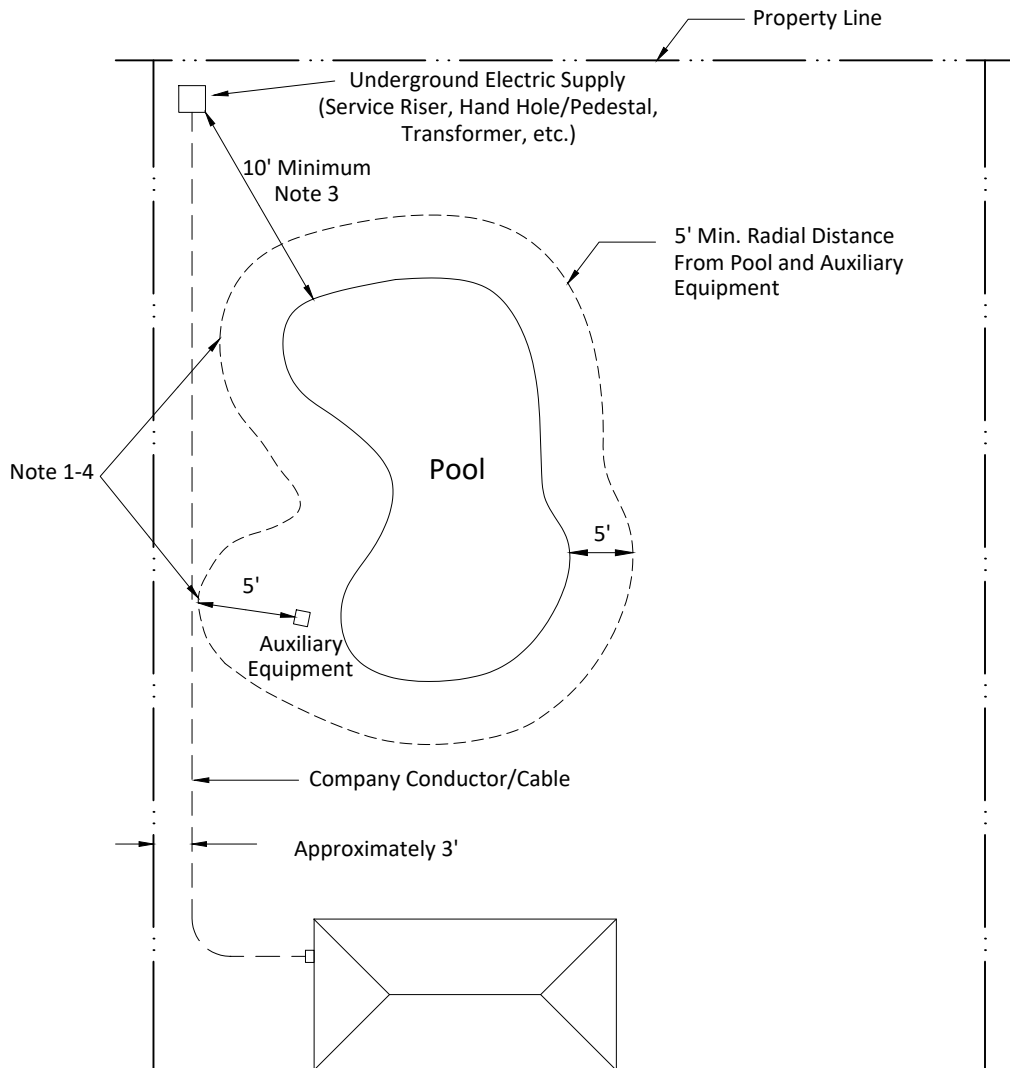

Notes:

1. Company Conductor/Cable - Oncor Electric Delivery Company LLC and its officers, agents, employees, successors, and assigned owned cable and/or conductor. (i.e. primary, secondary, service lateral)
2. A swimming pool or its auxiliary equipment or water pipes shall not be installed within 5 feet of direct-buried company conductor/cable.
3. Where a swimming pool must be installed within 5 feet of an existing direct-buried primary, secondary, and/or service, the primary, secondary, and/or service shall be installed in a continuous conduit to the point of delivery (POD).
4. Conduits installed for company conductor/cable shall be a minimum of 2 feet from the water's edge of the swimming pool. This distance applies to new pool site conduits and to the re-routing of existing company primary, secondary, and/or service.
5. The swimming pool auxiliary equipment conduits, conductors, water pipes, or customer owned facilities may not be installed in the same trench as the company conductor/cable.
6. Pad mounted equipment shall be located 10 feet or more from the water's edge.
7. Local requirements may require greater clearances.
8. For additional information related to company conductor/cable and swimming pools see document DDS1PR at Oncor.com.
9. Allowing pools and pool equipment as close as 2 feet from Oncor owned medium voltage cables (5 through 25 kV) may require the Oncor R.O.W. Department involvement.

CLEARANCES OF PAD MOUNTED TRANSFORMERS FROM BUILDING

FIGURE 2-D

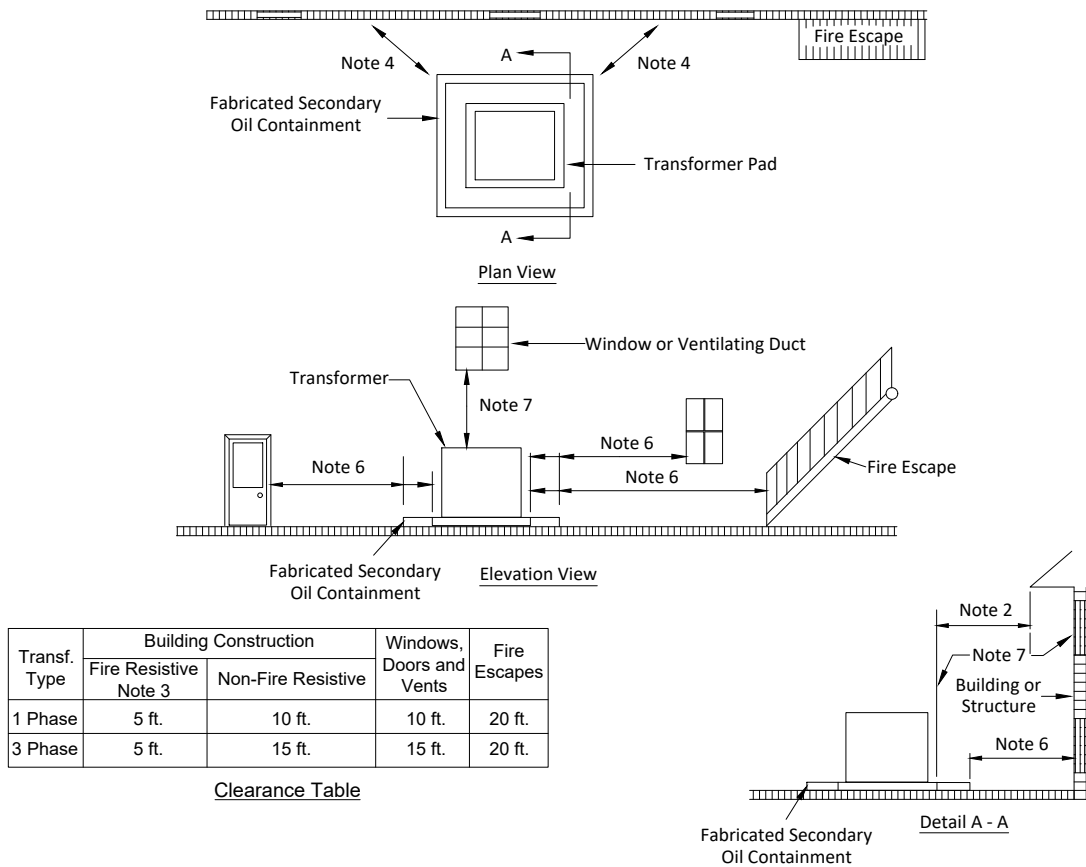

Notes:

1. Clearance from building walls shall comply with the clearance table. All dimensions are minimal dimensions.
2. Where there are building eaves or overhangs within 25 feet above ground, clearance shall be measured horizontally beginning from the edge of the eave or overhang.
3. Fire resistive building walls include brick and masonry structures that have a 2 hour fire rating.
4. Clearance to building doors, windows, vents and fire escapes to be measured radially.
5. Liquid flow in area surrounding transformer should be away from building. Where ground is flat or slopes toward building, a fabricated secondary oil containment sufficient to contain all transformer oil for transformers 500 KVA and larger shall be provided.
6. Clearances are measured from pad edge to building wall, opening, overhang or fire escape unless a fabricated secondary oil containment device is utilized.
7. Clearances from windows and vents above transformer are measured radially from closest point on transformer.
8. Pad mounted transformers shall be positioned such that hotstick use is not required on the side facing the building. If hotstick use is required on the building side, clearances shown in Figure 2-E, page 22 shall be maintained.
9. There should not be any above ground obstructions, such as shrubs, cooling towers, gas meters, fencing, etc. within 10 feet of pad or overhangs above pad facilities. Reference Figure 2-E, page 22 for screening clearances around pad mounted equipment.
10. There should not be any piping or conduit under the pad. Mutually agreed upon communication conduits other than those entering the transformer are allowed.
11. Transformers shall not obstruct fire lane.
12. It is the owner's responsibility to comply with any insurance regulations affecting the premises.

SCREENING CLEARANCES AROUND PAD MOUNTED EQUIPMENT

FIGURE 2-E

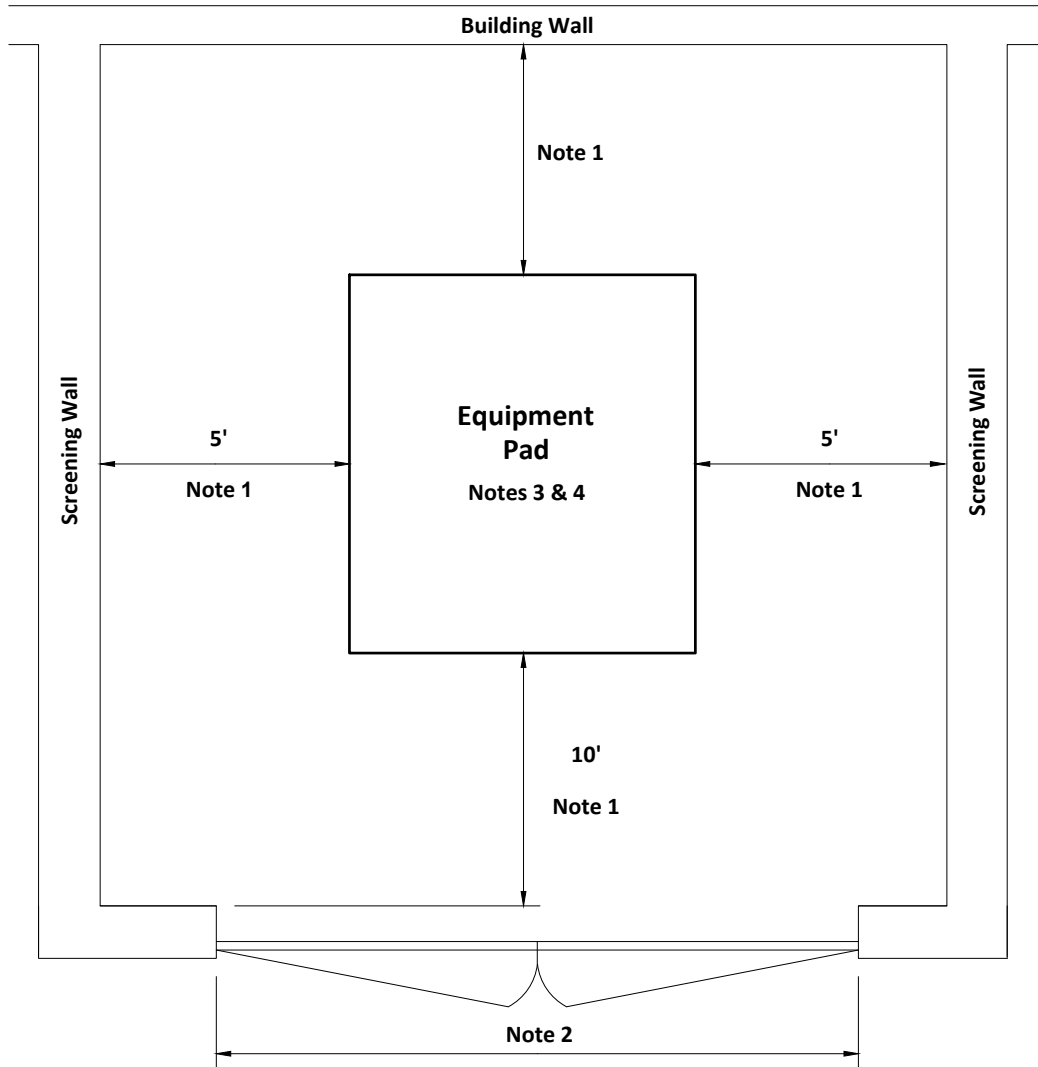

Notes:

- Clearances to building walls shall be the greater of:
 - The clearances listed in Figure 2-D, page 21 for oil filled equipment
 - 10 feet on operating side
 - 5 feet on non-operating side
- Gate shall open outward and the width shall be no less than 10 feet.
- Where ground is flat or slopes toward building, fabricated secondary oil containment sufficient to contain all oil for transformers 500KVA or larger shall be installed. Contact Company Representative for details.
- When transformers are installed, screening walls shall provide adequate ventilation.

SECTION 300

OVERHEAD SERVICE INFORMATION

- 300.01 General**
Company provides, installs, and maintains service drop to point of delivery approved by Company. Customer provides point of attachment which is acceptable to Company so that service drop meets requirements of all applicable codes.
- 300.02 Typical Permanent Service Drop**
See Figure 3-A, page 25.
- 300.03 Overhead Service Attachments**
See Figure 3-B, page 26.
- 300.04 Maximum Service Drop Length for Residential Services**
See Table 3-C, page 27.
- 300.05 Overhead Service, with Service Mast**
See Figure 3-D, page 28.
- 300.06 Overhead Service, Permanent Meter Pole**
See Figure 3-E, page 29.
- 300.07 Overhead Service, Wall Mount Meter**
See Figure 3-F, page 30.
- 300.08 Overhead Service, Two or Three Secondary Service Meters**
See Figure 3-G, page 31.
- 300.09 Overhead Service, Four or More Secondary Service Meters**
See Figure 3-H, page 32.
- 300.10 Overhead Service, Three-Wire Delta**
See Figure 3-I, page 33.

OVERHEAD SERVICE INFORMATION (cont'd)

300.11 Overhead Service to Mobile or Manufactured Homes

Overhead service to a mobile home shall be made in a manner as depicted in Figure 3-E, page 29 with a permanent meter pole. The meter socket shall not be mounted directly to the mobile home. Manufactured homes, if equipped with factory installed service equipment, may be connected directly if all three of the following requirements are met.

1. The manufactured home is secured to a permanent foundation by an approved anchoring system. Compliance with this requirement may be evidenced with one of the following:
 - a. The manufactured home structure is included in the real property deed
 - b. The foundation and anchoring system is designed by a Texas licensed engineer or Texas licensed architect, or
 - c. An affidavit from a home inspector is provided verifying that the foundation and anchoring system meets the Texas Administrative Code foundation and anchoring requirements for Manufactured Housing (TAC Title 10, Part 1, Chapter 80).
2. The service equipment complies with Article 230 of the National Electrical Code (NEC).
3. Bonding and grounding comply with Article 250 of the NEC. Manufactured home installations that meet the above requirements may be served as depicted in Figure 3-D, page 28. Service mast shall be of sufficient strength to support service drop. Contact Company representative prior to installation of mobile or manufactured homes to determine service method.

300.12 Other Overhead Services

For any situation that is not addressed, please contact Company representative for specific instructions.

Note: For temporary overhead service, see Section 600, page 73 and Figure 6-A, page 74.

TYPICAL PERMANENT OVERHEAD SERVICE DROP

FIGURE 3-A

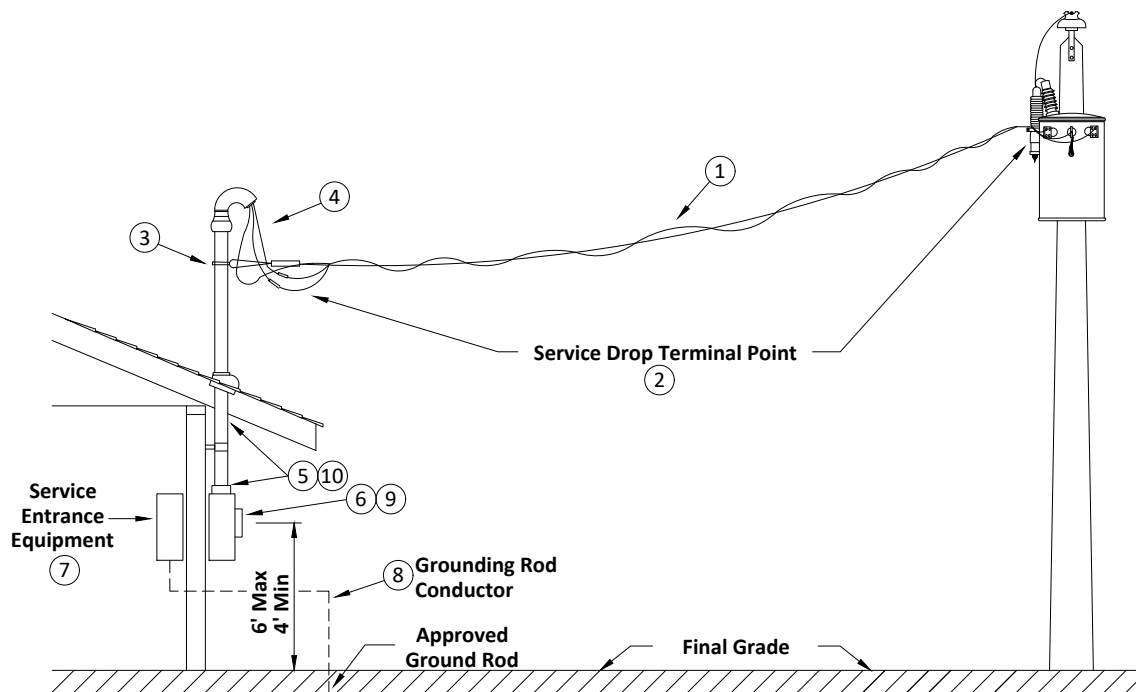

Notes:

1. Service drop (conductors, service grips and service connectors) owned, installed and connected to service entrance conductors by Company.
2. See Table 3-C, page 27 for maximum length of residential service drop. For all other services contact Company for maximum service lengths. Reduced distance or higher attachment point may be required for large service or to maintain minimum clearances.
3. Customer installs service drop attachment of adequate strength for attachment of Company's service drop conductors. See Figure 3-B, page 26.
4. Service entrance conductors (#8 Copper or #6 Aluminum minimum) provided and installed by Customer, shall extend 24 inches or the minimum length required by local ordinance outside the service head for connection to service drop. Phase conductors to have black insulation. Neutral conductor to be marked white or bare.
5. Service raceway and service entrance conductors to be owned, maintained, and installed by Customer.
6. Meter socket shall be provided, installed and maintained by Customer. Mounting height to Center is 4 feet minimum and 6 feet maximum, as measured from finished grade. See Table 5-C, pages 56-61 for list of approved meter sockets.
7. Customer's installation to meet the requirements of all applicable codes and local ordinances.
8. Customer's ground rod conductor (#6 Copper minimum) shall originate in the service entrance equipment and extend to an ground rod. The ground rod conductor is permitted to be routed through the meter socket enclosure, but **shall not** terminate within. Company reserves the right to refuse installation of service upon observing an unsafe Customer connection. The Company does not recognize Ufer Grounds as an approved grounding electrode for metering equipment. To be used by the customer for their service entrance facilities only.
9. Insulated conduit bushings are required for raceways terminating in the meter socket.
10. The use of flexible metallic conduit, liquid-tight flexible metallic conduit, and liquid-tight flexible non-metallic conduit for service entrance raceway is prohibited
11. For **3-wire delta services**, see **Figure 3-I, page 33**.

OVERHEAD SERVICE ATTACHMENTS

FIGURE 3-B

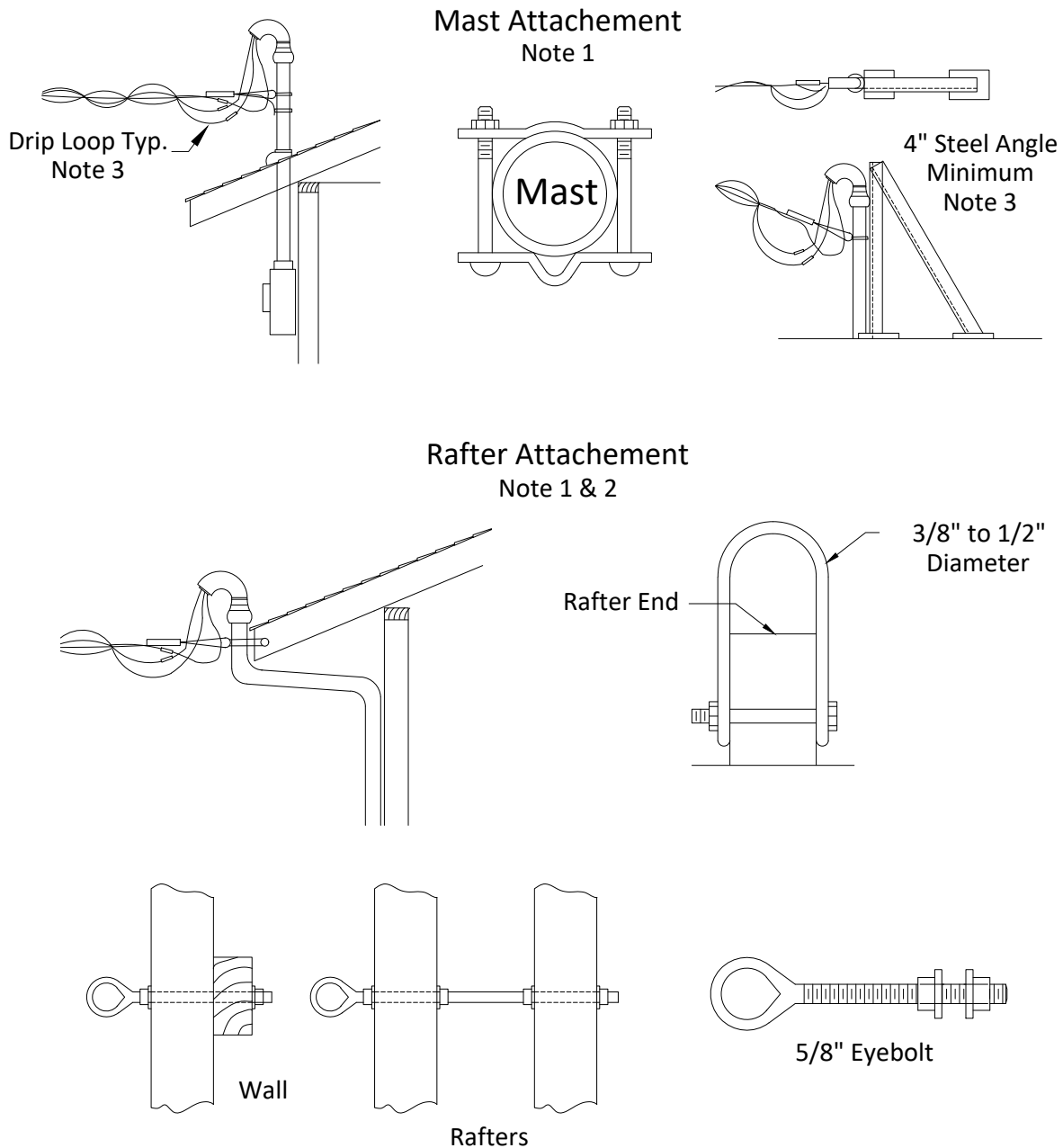

Notes:

1. Customer provides and installs service drop attachment of adequate strength for attachment of Company's service drop conductors.
2. Screw-in type service attachments are not allowed.
3. Service mast supporting service drop to be minimum 2 inch rigid steel or 2.5 inch IMC conduit with no coupling above top conduit clamp. EMT is not acceptable for service mast.
4. See Figure 3-I, page 33 for three-wire delta services.

MAXIMUM OVERHEAD SERVICE DROP LENGTH FOR RESIDENTIAL SERVICES

TABLE 3-C

FOR # 2 ALUMINUM TRIPLEX SERVICE CABLE (Note 2)

MINIMUM GROUND CLEARANCE REQUIRED (ft)	Minimum Attachment Height and Maximum Length of Service Drop		
10 (Note 3)	Attachment Height (ft)		
	12	11	10.5 (Notes 3 and 5)
	100 maximum length	90 maximum length	85 maximum length
12	Attachment Height (ft)		
	14	13	12
	95 maximum length	85 maximum length	60 maximum length
16	Attachment Height (ft)		
	18	17	16
	80 maximum length	70 maximum length	45 maximum length

Notes:

1. See Figure 2-A, page 16 for required clearance for single-phase 120/240 V service drop.
2. Distances based on #2 Aluminum triplex service drop. Contact Company representative for requirements on larger or longer services.
3. Prior approval by Company is required before the exceptions on Figure 2-A, page 16 may be considered.
4. Contact Company representative regarding commercial services or any service over 100 feet in length.
5. Attachment height of 10.5 feet is based on 6 inch allowance of drip loop below attachment point and the drip loop maintaining 10 feet clearance requirement.
6. Clearances and maximum lengths are based on service attachment to pole at 22 feet 3 inches.

OVERHEAD SERVICE MAST

FIGURE 3-D

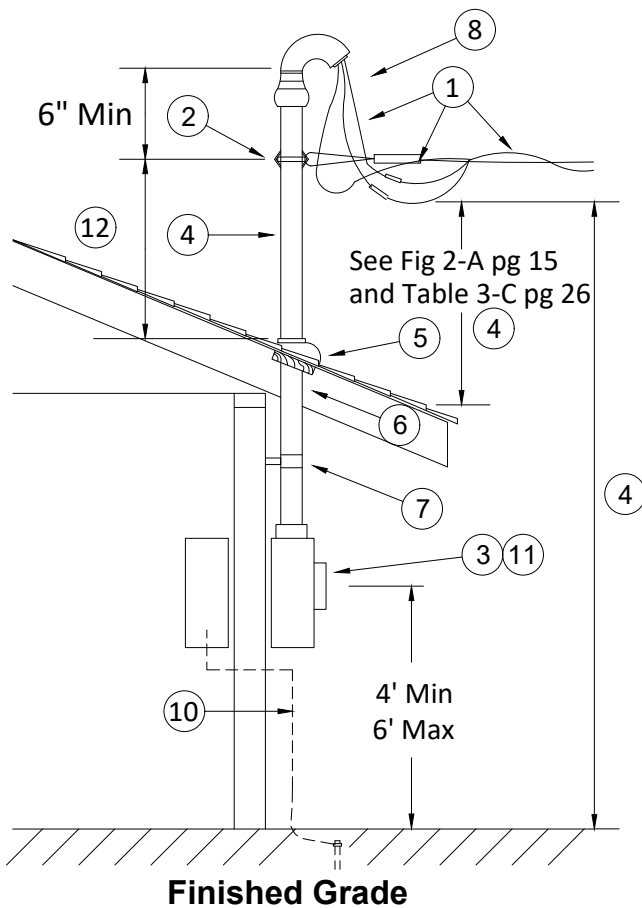

Notes:

1. Service drop provided and installed by Company.
2. Customer installs service drop attachment of adequate strength for attachment of Company's service drop conductors. See Figure 3-B, page 26.
3. Meter socket shall be provided, installed and maintained by Customer. Transockets, when required, shall be provided by Company and installed and maintained by Customer. Socket must be securely anchored to wall.
4. Service mast shall be of sufficient height for the service drop to meet minimum clearances (see Figure 2-A, page 16). A minimum 2 inch rigid steel conduit with no coupling above conduit clamp is required. EMT/PVC is not acceptable for service mast. Service mast to be of sufficient strength to support service drop.
5. Mast roof kit installed by Customer.
6. Install a 2 inch x 6 inch between rafters to reinforce roof decking for additional mast support.
7. Install a conduit hanger above meter socket for mast support.
8. Service entrance conductors (#8 Copper or #6 Aluminum minimum) provided and installed by Customer, shall extend 24 inches or the minimum length required by local ordinance outside of service head for connection to Company service drop. Phase conductors to have black insulation. Neutral conductor to be marked white or bare.
9. Customer's installation to meet requirements of all applicable codes and local ordinances. Typical single-phase service shown here. For three-phase see Figure 3-F, page 30.
10. Customer's ground rod conductor, #6 Copper minimum shall originate in the service entrance equipment and extend to a ground rod. The ground rod conductor is permitted to be routed through the meter socket enclosure, but **shall not** terminate within. Company reserves the right to refuse installation of service upon observing an unsafe Customer connection. The Company does not recognize Ufer Grounds as an approved grounding electrode for metering equipment. To be used by the customer for their service entrance facilities only.
11. Insulated conduit bushings are required for raceways terminating in the meter socket. See Table 5-C, pages 56-61 for list of approved meter sockets.
12. Customer shall install additional mast support (guying or other suitable support) to support the tension of the service drop cable if the service drop attachment (Note 2) is more than 5 feet above the roof line.
13. The use of flexible metallic conduit, liquid tight flexible metallic conduit, and liquid tight flexible non-metallic conduit for service entrance raceway is prohibited.
14. See Figure 3-I, page 33 for three-wire delta services.

OVERHEAD SERVICE, PERMANENT METER POLE

FIGURE 3-E

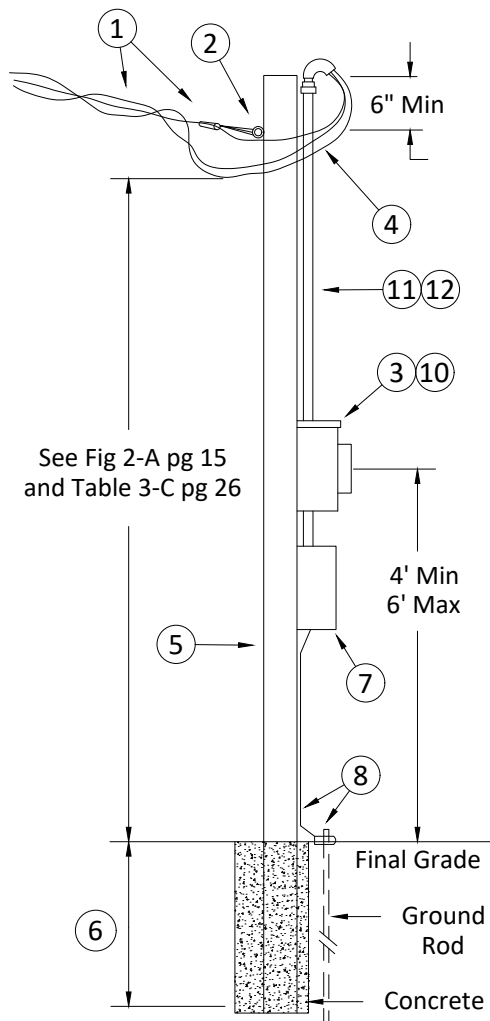

Notes:

1. Service drop provided and installed by Company.
2. Customer installs service drop attachment of adequate strength for attachment of Company's service drop conductors. See Figure 3-B, page 26.
3. Meter socket shall be provided, installed and maintained by Customer. Transockets, when required, shall be provided by Company and installed and maintained by Customer. Socket must be securely anchored.
4. Service entrance conductors (#8 Copper or #6 Aluminum minimum) and service raceway provided and installed by Customer, shall extend 24 inches or the minimum length required by local ordinance outside service head for connection to Company service drop. Phase conductors to have black insulation. Neutral conductor to be marked white or bare. Customer will bond 480 V neutral conductor to all metal service entrance raceways.
5. Customer to provide and install support for service attachment and meter socket. Creosote pole or equal to be 5 inch minimum diameter at top. Steel pipe to be 4.5 inch minimum outside diameter and a minimum thickness of 0.237 inches. Steel tube to be 4 inches square and a minimum thickness of 0.25 inch. Support to be sufficient height for the service drop to meet minimum clearances. See Figure 2-A, page 16.
6. Wood Pole to be set in 4 feet of concrete where soil conditions are less than rock. Steel pipe or tube to be set in 4 feet of concrete. Pole foam back-fill may be used, if approved by Company.
7. Weatherproof service switch or breaker panel is required for all permanent meter pole installations and is provided and installed by Customer.
8. Customer's ground rod conductor, #6 Copper minimum shall originate in the service entrance equipment and extend to a ground rod. The ground rod conductor is permitted to be routed through the meter socket enclosure, but **shall not** terminate within. Company reserves the right to refuse installation of service upon observing an unsafe Customer connection. The Company does not recognize Ufer Grounds as an approved grounding electrode for metering equipment. To be used by the customer for their service entrance facilities only.
9. Customer's installation to meet the requirements of all applicable codes and local ordinances.
10. Insulated conduit bushings are required for raceways terminating in the meter socket. See Table 5-C, pages 56-61 for list of approved meter sockets.
11. The use of flexible metallic conduit, liquid tight flexible metallic conduit, and liquid tight flexible non-metallic conduit for service entrance raceway is prohibited. The service raceway may not contain any conduit or other open connections.
12. The use of schedule 40 or 80 PVC for service mast not supporting service drop is allowed unless prohibited by the local inspecting authority. Service mast shall be of sufficient height for the service drop to meet minimum clearances (see Figure 2-A, page 16). A 2 inch rigid steel minimum with no coupling above conduit clamp is required. EMT/PVC is not acceptable for service mast. Service mast to be sufficient strength to support service drop.
13. For overhead service to mobile homes, see 300.11, page 24.
14. For **three-wire delta services**, see Figure 3-I, page 33.

OVERHEAD SECONDARY SERVICE, WALL MOUNTED METER

NON-RESIDENTIAL SINGLE OCCUPANCY STRUCTURES

FIGURE 3-F

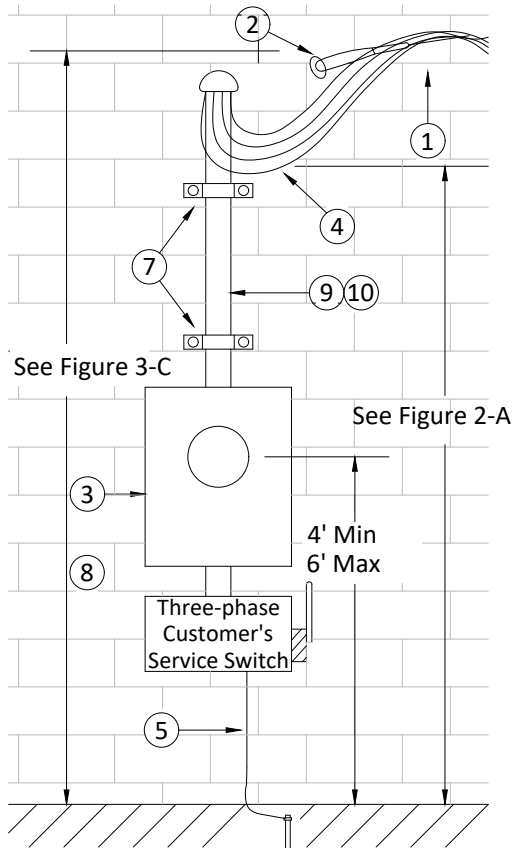

1. Service drops provided and installed by Company
2. Customer installs service drop attachment of adequate strength for attachment of Company's service drop conductors. See Figure 3-B, page 26.
3. Meter socket shall be provided, installed and maintained by Customer. Transockets, when required, shall be provided by Company and installed and maintained by customer. Socket must be securely anchored to wall.
4. Service entrance conductors (#8 Copper or #6 Aluminum minimum) and service raceway provided and installed by Customer, shall extend 24 inches or the minimum length required by local ordinance outside service for connection to service drop. Phase conductors to have black insulation. Neutral conductor to be marked white or bare.
5. Customer's ground rod conductor (#6 Copper minimum) shall originate in the service entrance equipment and extend to a ground rod. The ground rod conductor is permitted to be routed through the meter socket enclosure, but **shall not** terminate within. The Company does not recognize Ufer Grounds as an approved grounding electrode for metering equipment. To be used by the customer for their service entrance facilities only. Company reserves the right to refuse installation of service upon observing an unsafe Customer connection
6. Customer's installation to meet all requirements of all applicable codes and local ordinances.
7. Two or more conduit straps shall be provided to support conduit. Socket must be securely anchored to wall. The service raceway may not contain any conduit or other open connections.
8. Insulated conduit bushings are required for raceways terminating in meter socket.
9. The use of flexible metallic conduit, liquid tight flexible metallic conduit, and liquid tight flexible non-metallic conduit for service entrance raceway is prohibited. The service raceway may not contain any conduit or other open connections.
10. The use of PVC for service mast not supporting service drop is allowed unless prohibited by the local inspecting authority. Service mast shall be of sufficient height for the service drop to meet minimum clearances (see Figure 2-A, page 16). A 2 inch rigid steel minimum with no coupling above conduit clamp is required. EMT/PVC is not acceptable for service mast. Service mast to be sufficient strength to support service drop.
11. **Not for three-wire delta services, see Figure 3-I, page 33.**
12. If an existing single-occupancy structure customer requests that one or more additional three-phase meters be installed to convert to a multi-metered structure, then the customer must install a disconnecting means on the load side of each existing instrument rated meter installation on the structure and on each newly installed three-phase meter installation.
13. If there is a possibility of additional customers being served from the same transformer at another location, a service disconnect is required. This only applies for non-residential installations.
14. Single-phase services that utilize transockets for the metering equipment require a disconnecting means to be installed on the load side of the transocket. See Figure 5-D, pages 62-65 for instrument rated/transocket details.
15. Service disconnect switches and breakers are both acceptable for use as the disconnecting means. The disconnecting means must have provision for a Company lock. The disconnecting means must be readily accessible by Company and within close proximity of the meter. A 4 inch minimum clearance from the service disconnect switch operating lever is required. Customer must receive Company approval of electrical design and/or nonstandard equipment or locations prior to installation of equipment.

OVERHEAD TWO OR THREE SECONDARY SERVICE NON-RESIDENTIAL METERS FIGURE 3-G

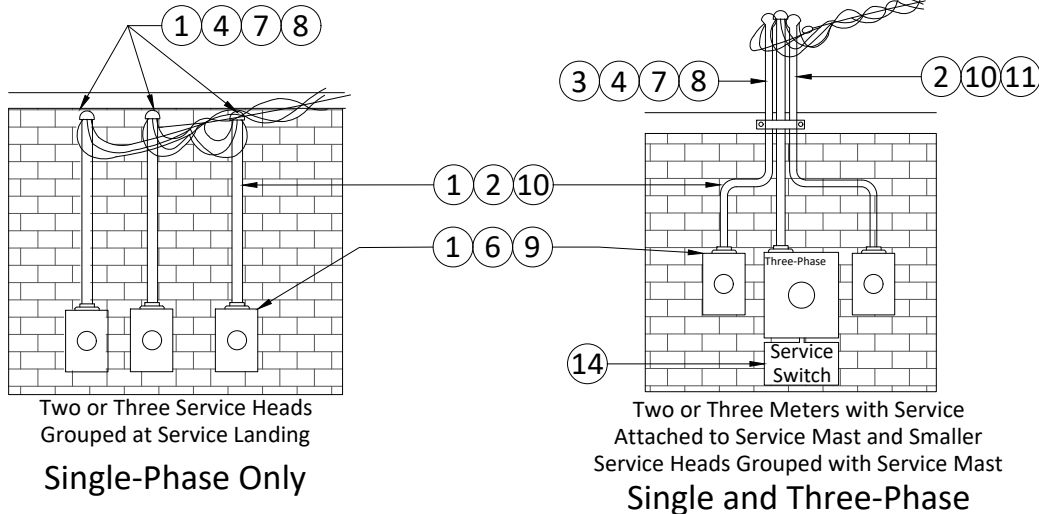

Notes:

1. Meter sockets shall be provided, installed and maintained by the Customer. Transockets, when required, shall be provided by Company and installed and maintained by Customer. Sockets must be securely attached to wall. See 500.11, page 47 for marking sockets and 500.04, page 43 for installation location. Customer installs service drop attachment of adequate strength for attachment of Company's service drop conductors. See Figure 3-B, page 26. Service landing must meet service drop clearances required per Figure 2-A, page 15. For Duplex and other multifamily installations, see Figure 5-F, page 67.
2. Service head, service raceway and service entrance conductors provided, installed and maintained by Customer. The service raceway may not contain any conduit or other open connections.
3. A 2 inch rigid steel conduit minimum, for service mast supporting service drop. No coupling in the mast may be at or above the roof line. Service mast shall be of sufficient strength to support the service conductors.
4. Service entrance conductors to extend from weatherhead to service landing, but in no case less than 36 inches minimum. Service head shall be located within 3 feet of service landing attachment.
5. It is Customer's responsibility to meet requirements of all applicable codes and ordinances.
6. For 240V four-wire delta services, the "power leg" must be connected to the right-hand terminals in meter sockets and be identified by orange insulation or painted orange at the weatherhead and in meter sockets.
7. Service heads must be grouped for service drop.
8. No more than three meter sockets (with a maximum of six service masts total) will be served in this manner. See Figure 3-H, page 32 for installations exceeding these requirements.
9. Insulated conduit bushings are required for raceways terminating in the meter base.
10. The use of flexible metallic conduit, liquid tight flexible metallic conduit, and liquid tight flexible non-metallic conduit for service entrance raceway is prohibited.
11. PVC for service mast not supporting service drop is allowed unless prohibited by local inspecting authority. Service mast shall be of sufficient height for the service drop to meet minimum clearances (see Figure 2-A, page 16). A 2 inch rigid steel minimum with no coupling above conduit clamp is required. EMT/PVC is not acceptable for service mast. Service mast to be sufficient strength to support service drop.
12. Each socket must be clearly and permanently marked as indicated in 500.11, page 47.
13. **Not for three-wire delta services. See Figure 3-I, page 33.**
14. Instrument rated service to a non-residential structure must be equipped with a disconnecting means installed on the load-side of the instrument rated metering equipment where the metering equipment is installed on a customer structure, unless prohibited by local governing authority.
15. Service disconnect switches and breakers are both acceptable for use as the disconnecting means. The disconnecting means must have provision for a Company lock. The disconnecting means must be readily accessible by inspection authority and within close proximity of the meter. A 4 inch minimum clearance from the service disconnect switch operating lever is required. Customer must receive inspection authority approval of electrical design and/or nonstandard equipment or locations prior to installation of equipment. Service disconnects are not required for non-instrument rated single-phase installations.

OVERHEAD SERVICE, FOUR OR MORE SECONDARY SERVICE NON-RESIDENTIAL SERVICE FIGURE 3-H

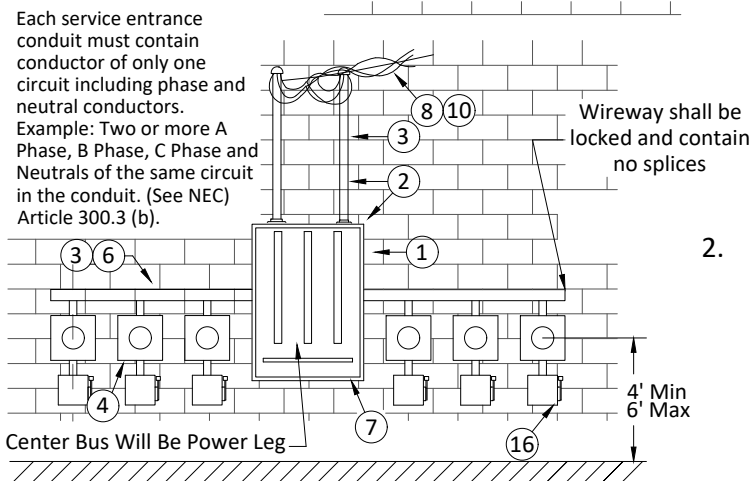

Notes:

1. A service enclosure (see 500.08, page 47) installed by Customer on outside wall of building, is required for Secondary Service installations through 2500 amperes with four or more meter sockets. See Figure 3-G, page 31 for installations of less than four meter sockets. Contact Company for determination of service enclosure requirements. For multifamily installations, see Figure 5-F, page 67. **Not for three-wire delta services. See Figure 3-I, page 33.**
2. Service head, service raceway and main service entrance conductors provided, installed and maintained by Customer. The service raceway may not contain any conduit or other open connections. Line-side conductors from weatherheads are to contact the center of bus bars. Load conductors to meter sockets to be connected equally on both ends of bus bars to obtain full current rating.
3. Conductors and raceways provided, installed and maintained by Customer. Service head, service raceway and main service entrance conductors provided, installed and maintained by Customer. A 2 inch rigid steel conduit minimum, for service mast supporting service drop. No coupling in the mast may be at or above the roof line. Service mast shall be of sufficient strength to support the service conductors.
4. Meter sockets shall be provided, installed and maintained by Customer. Transockets, when required, shall be provided by Company and installed and maintained by Customer. See Figure 5-D, pages 62-65 for instrument rated/transocket details.
5. For use on service voltages through 480 V.
6. Service entrance conductors to be continuous from meter sockets to service enclosure. Service enclosure, meter socket and wireways shall be locked.
7. Customer provides all connectors and makes all connections in the enclosure. Approved connectors, plated .375 inch minimum diameter bolts, Belleville washers, and oxide inhibitor are required for connections to plated aluminum bus.
8. See Figure 2-A, page 16 for service drop clearances.
9. Service switches, when installed near the service enclosure, should not interfere with service to an occupancy.
10. Service entrance conductors to extend from weatherhead to service landing, but in no case less than 36 inch minimum. Service head(s) shall be located within 3 feet of service landing attachment. No more than six service masts allowed without prior Company approval.
11. Customer installs service drop attachment of adequate strength for Company's service drop conductors. See Figure 3-B, page 27.
12. Insulated conduit bushings are required for raceways terminating in the meter base.
13. The use of flexible metallic conduit, liquid tight flexible metallic conduit, and liquid tight flexible non-metallic conduit for service entrance raceway is prohibited.
14. Each socket must be clearly and permanently marked as indicated in 500.11, page 47, before a meter can be set or installed.
15. The use of PVC for service mast not supporting service drop is allowed unless prohibited by the local governing authority. Service mast shall be of sufficient height for the service drop to meet minimum clearances (see Figure 2-A, page 16). A 2 inch rigid steel minimum with no coupling above conduit clamp is required. EMT/PVC is not acceptable for service mast. Service mast to be sufficient strength to support service drop.
16. Instrument rated service to a multi-tenant structure must be equipped with a disconnecting means installed on the load-side of the instrument rated metering equipment where the metering equipment is installed on a customer structure. Service disconnect switches and breakers are both acceptable for use as the disconnecting means. A service disconnect switch for single-phase instrument rated installations is required. The disconnecting means must have provision for a Company lock. The disconnecting means must be readily accessible by Company and within close proximity of the meter. A 4 inch minimum clearance from the service disconnect switch operating lever is required. Customer must receive Company approval of electrical design and/or nonstandard equipment or locations prior to installation of equipment.

OVERHEAD SERVICE, THREE-WIRE DELTA

FIGURE 3-I

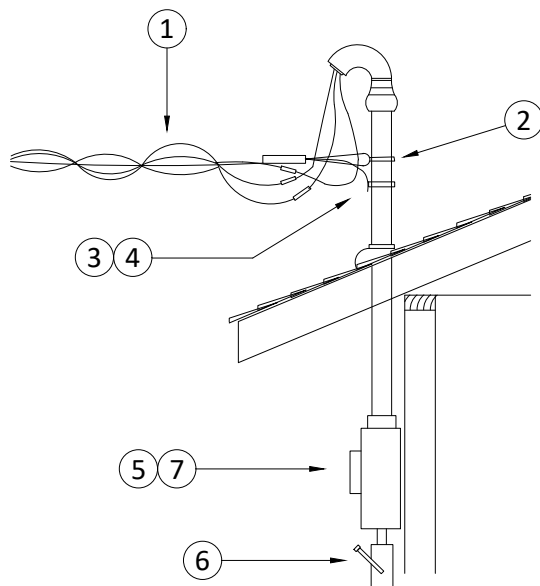

Notes:

1. Service drop conductor (quadruplex) provided, installed, and connected by Company.
2. Customer installs service drop attachment of adequate strength for attachment of Company's service drop conductors. See Figure 3-B, page 26.
3. Service mast shall be of sufficient height for the service drop to meet minimum clearances (see Figure 2-A, page 16). A 2 inch rigid steel minimum with no coupling is required. EMT/PVC is not acceptable for service mast. Service mast to be of sufficient strength to support the service drop. The service mast may not contain any conduit or other open connections.
4. Customer to install conduit grounding clamp for bonding service drop messenger to service raceway. Company shall connect service messenger to the neutral at the transformer pole, ground at every intermediate pole, and connect to the conduit grounding clamp at the service raceway.
5. Meter socket enclosure and service raceways shall be connected to the grounded system conductor or to the grounding rod conductor as per the NEC. See 500.04, pages 43 for location of meter.
6. Non-residential single occupancy structure customers metered by instrument rated metering equipment and served from a non-dedicated transformer (i.e. other customers may be served from this transformer) will require a disconnecting means installed on the load-side of the instrument rated metering equipment where the instrument rated metering equipment is installed on a customer structure, unless prohibited by local governing authority. Service disconnect switches and breakers are both acceptable for use as the disconnecting means. The disconnecting means must have provision for a Company lock. The disconnecting means must be readily accessible by Company and within close proximity of the meter. A 4 inch minimum clearance from the service disconnect switch operating lever is required. Customer must receive Company approval of electrical design and/or nonstandard equipment or locations prior to installation of equipment.
7. Meter socket shall be provided, installed and maintained by Customer. See Table 5-C, pages 56-61 for list of approved meter sockets. Transockets, when required, shall be provided by Company and installed by Customer. Customer will maintain Customer connections in the transocket. Meter sockets and Transockets shall be securely mounted to the structure. The mounting height as measured to the center of meter socket is a minimum of 4 feet to a maximum of 6 feet from final grade.
8. Customer's ground rod conductor, #6 Copper minimum shall originate in the service entrance equipment and extend to a ground rod. The ground rod conductor is permitted to be routed through the meter socket enclosure but **shall not** terminate within. Company reserves the right to refuse installation of service upon observing an unsafe Customer connection. Ufer grounds are not recognized as an approved grounding electrode.

SECTION 400

UNDERGROUND SERVICE INFORMATION

400.01 **General**

Underground service is provided to Customer who meets Company requirements set out herein and pays to Company any amount due. **All conduit shall be at 24 inch minimum burial depth to the top of the conduit in accordance with NEC regulations.** Cash payments or other arrangements satisfactory to Company are made by Customer prior to Company beginning construction. All underground facilities included in the cost estimates are provided, installed, owned and maintained by Company.

Where Company provides delivery service underground, Company retains the right to limit delivery service to such underground, network, and/or dual feed distribution systems.

400.02 **Underground Service Lateral for Underground Residential Customers and Non-Residential Service Customers served from Overhead Transformation**

The Company owns and maintains the service lateral conductor and raceway to the Point of Delivery, see 100.01.42 page 8. The Company installs the service lateral conductor. The Customer has the option of installing the raceway connecting the Company's distribution system to Customer's point of delivery, reference Drawings, pages 48-55. Where Customer installs or plans to install obstructions (e.g., asphalt or concrete walk, driveway, retaining wall, paved parking lot, etc.) in the path of Company's service lateral, Company will require Customer to provide and install raceway for Company's service lateral to Company specifications. Should Customer not install necessary raceway for service lateral prior to the installation of obstructions or should Customer's service route change after the installation of obstructions where no raceway exists for new service lateral location, Customer must make the necessary raceway installations prior to service lateral installations. Contact Company representative for details.

Customer is to establish final grade before service lateral can be installed. Conduit must meet 24 inch NEC burial depth to the top of the conduit requirement. For residential installations, an inspection may be performed. For commercial and industrial installation, an inspection prior to cover up is mandatory. Any change in final grade which results in the lowering or raising of service lateral raceway or associated equipment is at the expense of the Customer. When installed by Company, service lateral will be run in a straight line. A clear path wide enough to permit passage of excavation equipment is required. It is the Customer's responsibility to clear all obstructions before service lateral installation starts. Customer is also responsible for marking or exposing any plumbing. The Company will not be responsible for damaging private plumbing.

Company owned service lateral raceways are to be located on the exterior of the building.

400.03 **Underground Services to Non-Residential Service Customers Fed from Pad mounted Transformers, Handholes, or Service Pedestals for all three-phase and single-phase greater than or equal to 20 kW**

Secondary Service Customers fed from pad mounted transformers, handholes, or service pedestals are to furnish, install, own and maintain the service lateral conductors including raceway(s) to the device terminals. Customer will furnish and Company will install physical connections at POD. Conductor size limits are based on equipment terminal configurations. For single-phase pad mounted transformers the maximum size secondary service conductors is 500 kcmil. For Service Enclosures maximum conductor sizes refer to Typical Service Enclosures, Figure 5-E, page 66. Where fed from three-phase pad mounted transformers three-wire or four-wire delta service is not available. For three-phase transformers and Secondary Enclosures the Customer conductor size shall be limited to 1000 kcmil. See pages 48-55 for Company-Customer responsibility.

UNDERGROUND SERVICE INFORMATION (cont'd)

400.04 Underground Services to Multi-metered Apartments

The Company will provide and install the source conductor and conduit to the P.O.D. for Multi-Family Residential with the standard service voltage of 120/240V. The Customer may provide and install the conduit with the approval from the Company and per Company specifications. The conduit and conductor for all other voltage other than 120/240V to Multi-Family Residential will be the customers responsibility. If the number of conductors exceeds the pad mounted transformer secondary terminal connection limitations, the Company may require a pad mounted secondary enclosure. See 100.01.43, page 8 and 500.09, page 47.

400.05 Underground Service, Self-contained Meter Wiring

See Figure 4-A, page 37.

400.06 Underground Three-Phase and Single-Phase Service Meter for One Residential or One Non-Residential (One Secondary) Service

See Figure 4-B, page 38.

400.07 Underground Service, Two or More Non-Residential Service Meters with Service Enclosure

See Figure 4-C page 39.

400.08 Underground Service Meter Pack, Multi-Meter Installation

See Figure 4-D, page 40.

400.09 Underground Service, Meter Rack

See Figure 4-E, page 41.

400.10 Underground Service to Mobile or Manufactured Homes

Underground service to a mobile home shall be made in a manner as depicted in Figure 4-E, page 41. The meter socket shall not be mounted directly to the mobile home. Manufactured homes, if equipped with factory-installed service equipment, may be connected as depicted in Figure 4-B, page 38 if all three of the following requirements are met.

1. The manufactured home is secured to a permanent foundation by an approved anchoring system. Compliance with this requirement may be evidenced with one of the following:
 - a. the manufactured home structure is included in the real property deed,
 - b. the foundation and anchoring system is designed by a Texas licensed engineer or Texas licensed architect, or
 - c. an affidavit from a home inspector is provided verifying that the foundation and anchoring system meets the Texas Administration Code Foundation and anchoring requirements for Manufactured Housing (TAC Title 10, Part 1, Chapter 80).
2. The service equipment complies with Article 230 of the National Electric Code (NEC).
3. Bonding and grounding comply with Article 250 of the NEC. Contact Company prior to installation of mobile or manufactured homes to determine service method.

UNDERGROUND SERVICE INFORMATION (cont'd)

400.11 Service to Recreational Vehicle (RV) Park

Per the Company tariff, an RV is not considered an Individual Private Dwelling and cannot be placed on the Residential Rate. RV parks shall not be provided meters to each RV pad site regardless of the period of time RVs are located at an RV park whether permanent residence or not. RVs are to be treated differently than mobile home parks. RVs are not mobile homes and cannot be served in the same manner.

Company practice is to design and supply service to RV parks with a negotiated minimal number of points of delivery. These points should be based on load and/or voltage drop on Customer owned facilities. Each point of delivery is setup under the Secondary Rate. The owner of the park still has the option to provide their own meters to individual pad sites by following PUC rules, if they so desire.

400.12 Other Underground Services

For any situation that is not addressed, please contact Company for specific instructions.

Notes:

1. For temporary underground service, see Section 600, page 73 and Figure 6-B, page 75.
2. For underground utility cable locating service - Call 811 - before you dig.

UNDERGROUND SINGLE-PHASE SERVICE, SELF-CONTAINED METER WIRING, SINGLE OCCUPANCY STRUCTURES

FIGURE 4-A

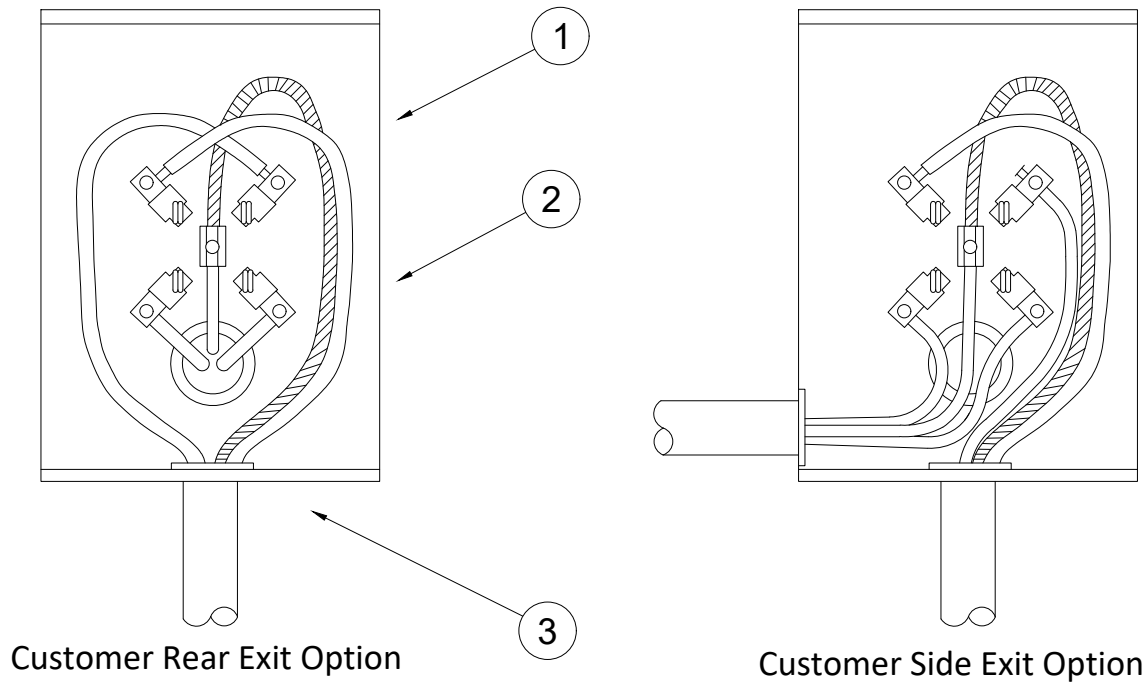

Notes:

1. Company owned service lateral conductors are installed by Company and line-side (top) connections made up by Company. Customer's service conductors are installed and connected in socket by Customer. **Customer's load conductors for self-contained meter sockets may not exit top half of meter socket enclosure.**
2. Meter socket shall be provided, installed, and maintained by the customer. See Table 5-C, pages 56-61 for list of approved meter sockets.
3. An insulated conduit bushing is required for raceways terminating in the meter socket. The service raceway may not contain any conduit or other open connections. See Figure 4-B, page 38 for oversized PVC conduit/raceway fitting details.
4. Customer's ground rod conductor, #6 Copper minimum shall originate in the service entrance equipment and extend to a ground rod. The ground rod conductor is permitted to be routed through the meter socket enclosure, but **shall not** terminate within. Company reserves the right to refuse installation of service contingent upon inspection of Customer's grounding connections.
5. Reference 400.02, page 34 for Company or Customer responsibility for service lateral raceway installation. Schedule 80 PVC or Schedule 40 PVC (if permitted by local code) is required for underground service lateral raceway. **Rigid steel, IMC, or EMC is not allowed.**
6. The use of flexible metallic conduit, liquid tight flexible metallic conduit, and liquid tight flexible non-metallic conduit for service entrance raceway is prohibited. The service raceway shall not contain any conduit or other open connections.
7. Service riser conduit must be straight and in-line with the meter socket with at least 3 feet of service riser raceway above grade. The service raceway shall not contain any conduit or other open connections.
8. Company service lateral conductors must enter from the **BOTTOM** of the meter socket, not from the side and not from the top. Line and load side conductors **shall not** cross.
9. An oversized PVC conduit/raceway fitting that slips over the service lateral conduit riser is required. This fitting prevents exposure of conductors due to conduit/raceway movement due to soil expansion and contraction. Conduit inserted a minimum of 12 inches into the fitting. See Figure 4-B, page 38 for illustration.

UNDERGROUND THREE-PHASE AND SINGLE-PHASE SERVICE METER FOR ONE RESIDENTIAL OR ONE NON-RESIDENTIAL (ONE SECONDARY) SERVICE

FIGURE 4-B

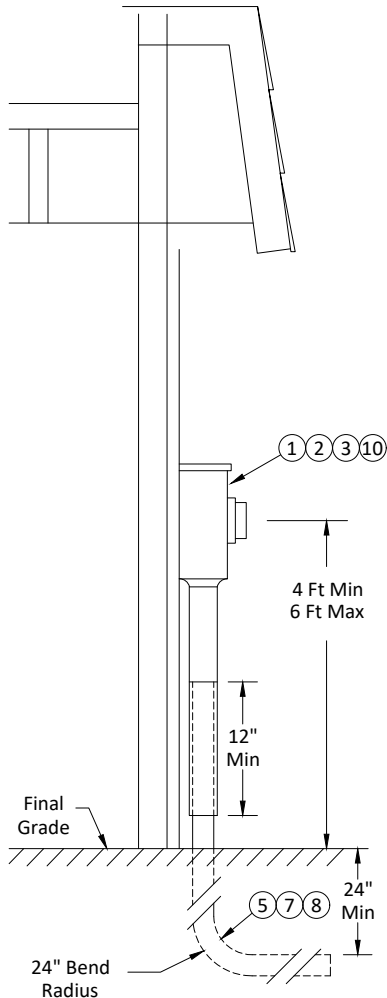

Notes:

1. See Drawings, pages 48-55 for Company-Customer responsibility of source and load conductors and connection of these conductors.
2. Meter socket shall be provided, installed, and maintained by Customer. See Table 5-C, pages 56-61 for list of approved meter sockets. Transockets, when required, shall be provided by Company and installed and maintained by Customer. All meter sockets (excluding transockets) require the line-side conductors to be connected to the top meter socket terminals. **Customer load conductors may not exit top half of meter socket.**
3. An insulated conduit bushing is required for raceways terminating in the meter socket. The service raceway shall not contain any conduit or other open connections.
4. Customer's ground rod conductor, #6 Copper minimum shall originate in the service entrance equipment and extend to a ground rod. The ground rod conductor is permitted to be routed through the meter socket enclosure, but **shall not** terminate within. Company reserves the right to refuse installation of service contingent upon inspection of Customer's grounding connections.
5. Reference 400.02, page 34 and 400.03, page 34 for Company or Customer responsibility for service lateral raceway installation. Schedule 40 PVC is required for Company owned underground service lateral raceways. **Rigid steel, IMC, or EMT is not allowed.** Contact Company representative prior to installation to determine service lateral raceway size, 2 inches is minimum.
6. If there is a possibility of additional customers being served from the same transformer at another location, a service disconnect is required. This only applies for instrument rated metering installations, unless prohibited by governing authority.
7. The use of flexible metallic conduit, liquid tight flexible metallic conduit, and liquid tight flexible non-metallic conduit for service entrance raceway is prohibited.
8. Service lateral conductor must enter from the **BOTTOM** of the meter socket, not from the side and not from the top. Service lateral conductor must be straight and inline with the meter socket with at least 3 feet of service lateral raceway above grade.
9. An oversized PVC conduit/raceway fitting that slips over the service lateral conductor riser is required. This fitting prevents exposure of conductors due to conduit/raceway movement due to soil expansion and contraction. Conduit inserted a minimum of 12 inches into the fitting.
10. Company owned service lateral conductors are installed by Company and line-side (top) connections made up by Company. Customer's service conductors are installed and connected in socket by Customer.
11. Company recommends that Customer limit to one circuit per conduit to avoid potential loading problems.

UNDERGROUND SERVICE METERS, TWO OR MORE NON-RESIDENTIAL WITH SERVICE ENCLOSURE

FIGURE 4-C

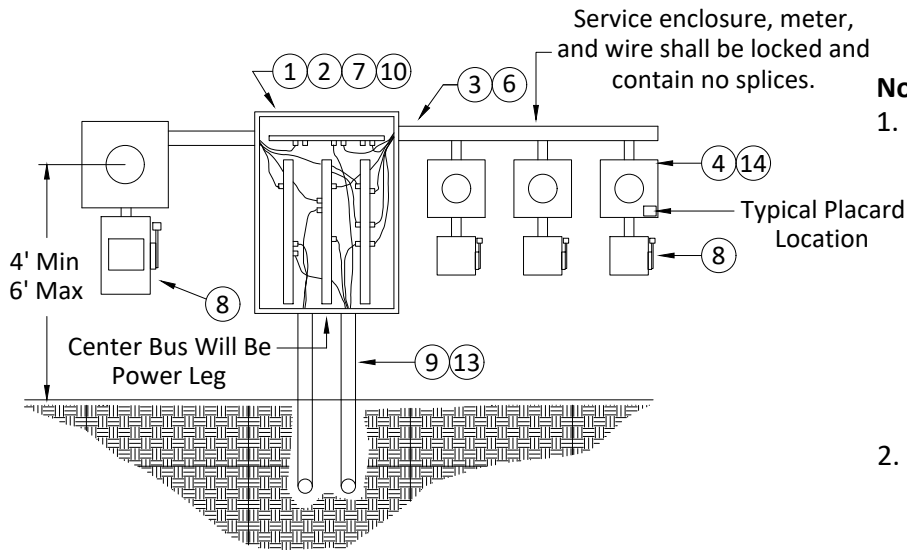

Notes:

1. A service enclosure (see 500.08, page 47) for Secondary Service installations through 2500 amperes and two or more meter sockets are required. Service enclosure shall be installed by Customer on outside wall of building. Contact Company for determination of service enclosure requirements. For Duplex and multifamily installations, see Figure 5-F, page 67.
2. Load conductors to meter sockets to be connected equally on both ends of bus bars to obtain full current rating of bus bars. Line conductors shall be connected to center of bus bars.

3. Conductors, gutters and raceways provided, installed and maintained by Customer. Company locks or seals may be required.
4. Meter sockets shall be provided, installed and maintained by Customer. Transockets, when required, shall be provided by Company and installed by Customer. Company locks or seals will be installed at each meter socket. See Table 5-C, pages 56-61 for list of approved meter sockets.
5. For use on service voltages through 480V.
6. Service entrance conductors to be continuous from meter sockets to service enclosure.
7. Refer to Drawings, pages 48-55 for connector/conductor responsibility in service enclosures. Approved connectors, plated .375 inch minimum diameter bolts, Belleville washers, and oxide inhibitor are required for connections to plated aluminum bus.
8. Instrument rated service to a non-residential structure must be equipped with a disconnecting means installed on the load-side of the instrument rated metering equipment where the metering equipment is installed on a customer structure, unless prohibited by local governing authority. Service disconnect switches and breakers are both acceptable for use as the disconnecting means. The disconnecting means must have provision for a Company lock. The disconnecting means must be readily accessible by Company and within 3 feet of the meter. A 4 inch minimum clearance from the service disconnect switch operating lever is required. Customer must receive Company approval of electrical design and/or nonstandard equipment or locations prior to installation of equipment.
9. For service lateral installation refer to 400.02, page 34. The service raceway shall not contain any conduit or other open connections.
10. For underground services, the bottom section of the enclosure shall be reserved for the line-side conductors. Load side conductors are not permitted to exit bottom.
11. If there is a possibility of additional instrument rated installations being served from the same transformer at another location, a service disconnect is required.
12. Insulated conduit bushings are required for raceways terminating in the meter socket.
13. The use of flexible metallic conduit, liquid tight flexible metallic conduit, and liquid tight flexible non-metallic conduit for service entrance raceway is prohibited.
14. Schedule 40 PVC is required for Company owned underground service lateral raceways. **Rigid steel, IMC, or EMT is not allowed.**
15. Each socket must be clearly and permanently marked as indicated in 500.11, page 47.

UNDERGROUND SERVICE METER PACK, MULTI-METER INSTALLATION

FIGURE 4-D

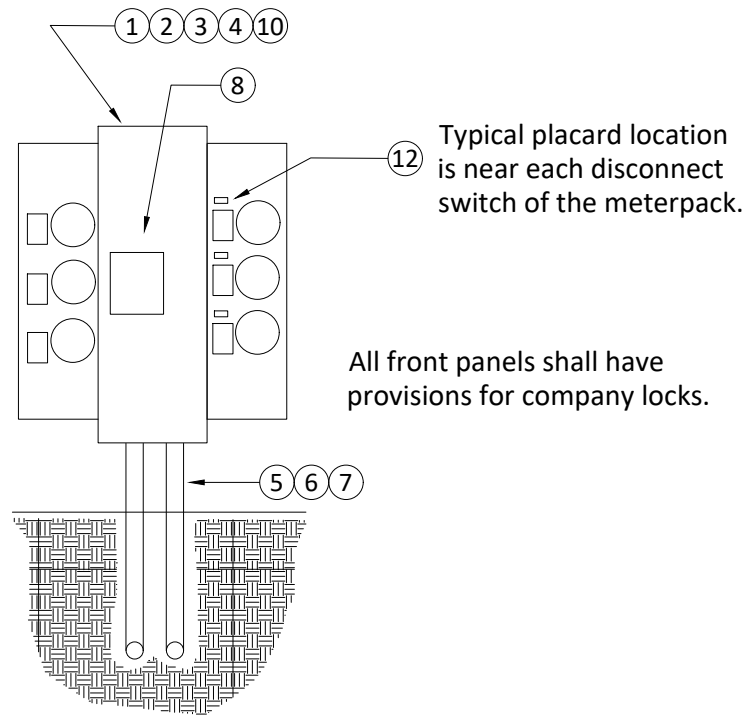

Notes:

1. A meter pack, installed by Customer on outside wall of building for Secondary Service installations for two or more meter sockets, may be installed in lieu of a service enclosure. **Contact Company for approval of meter packs prior to letting bids and installing equipment.** For multifamily installations, see Figure 5-F, page 67.
2. Meter packs provided, installed, and maintained by Customer.
3. Refer to Drawings, pages 48-55 for connector/conductor responsibility in meter pack.
4. When utilizing meter packs to serve Secondary Service Customers, lever-operated bypass mechanisms are required for each individual meter socket.
5. If 7 or more meters are able to be installed, a service disconnect must be used on the line side of the meter pack. Check with city for additional requirements.
6. All meter packs must be ringless.
7. For service lateral installation refer to 400.02, page 34. The service raceway shall not contain any conduit or other open connections.
8. The use of flexible metallic conduit, liquid tight flexible metallic conduit, and liquid tight flexible non-metallic conduit for service entrance raceway is prohibited. The service raceway may not contain any conduit or other open connections.
9. Schedule 40 PVC is required for Company owned underground service lateral raceways. **Rigid steel, IMC, or EMT is not allowed.**
10. Meter packs with meter stacks up to 5 meters tall will be permitted under certain conditions. Maximum mounting height is 72 inches to the center of the top meter socket. For meter stacks that have 5 vertical positions, a permanent hard surface extending a minimum of 24 inches in front of the meter pack and the width of the meter pack is required. Contact Company for details.
11. **It is the Customer's responsibility to determine local code requirements concerning meter packs with main switches or main circuit breakers prior to installing equipment.**
12. Each socket must be clearly and permanently marked as indicated in 500.11, page 47. Apartment or Location placards shall be mounted on meter pack adjacent or the tenant breaker, as an alternate mounting position. Screws and rivets are not allowed to attach placards.

UNDERGROUND SERVICE, METER RACK

FIGURE 4-E

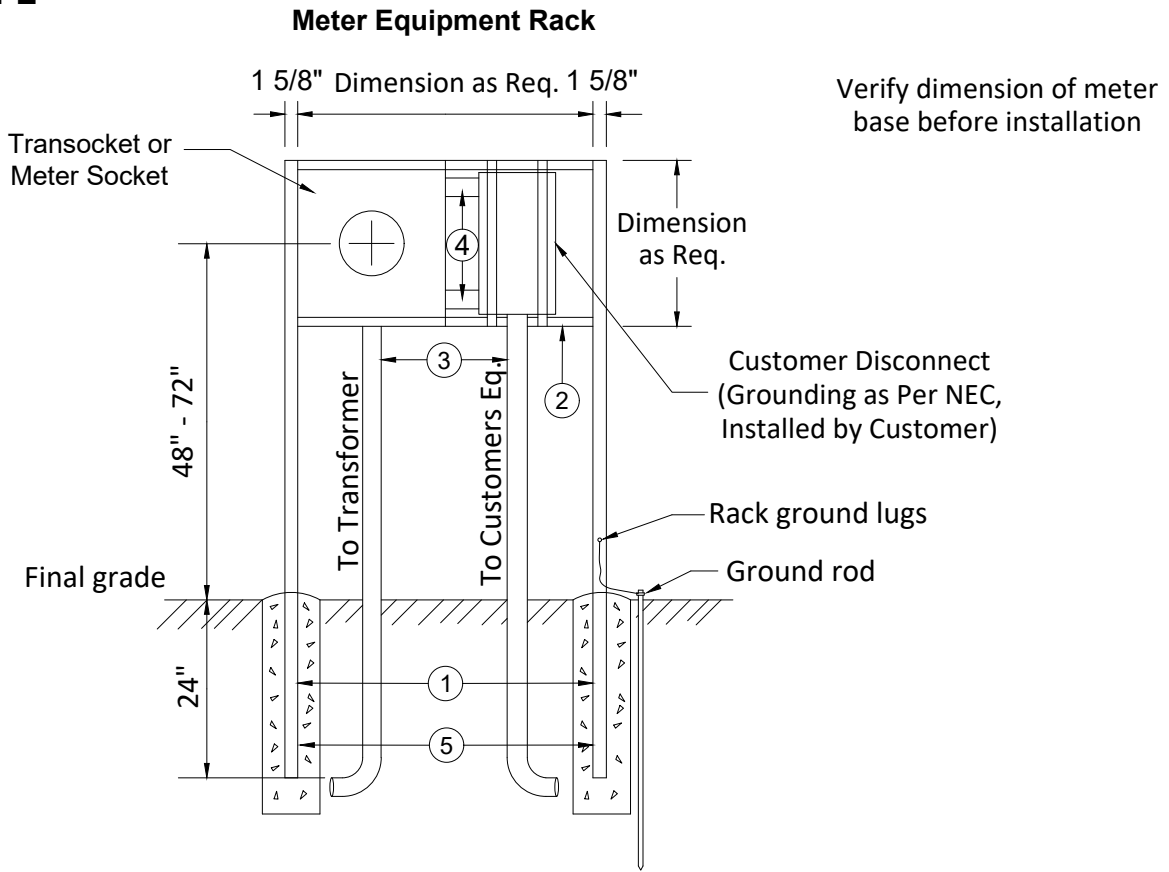

Item	Qty	Description
1	2	Strut Channel (1 5/8" x 1 5/8" x 8'), galvanized
2	2	Strut Channel (1 5/8" x 1 5/8" x 1/8" x 36"), galvanized
3	2	Conduit, Schedule 80 PVC, as required
4	1	Conduit, nipple, as required (lowered for meter socket - upper for transocket)
5		Concrete, as required

Notes:

1. Company owned service lateral conductors are installed by Company and line-side (top) connections made up by Company. Customer service conductors are installed and connected in socket by Customer.
2. Meter socket, rack and conduit/risers provided, installed and maintained by Customer. A 4 inch minimum clearance from the disconnect switch operating-lever is required. See Table 5-C, pages 58-61 for list of approved meter sockets.
3. Service lateral or source conductors provided and installed as per 400.02, page 34. The service raceway to transformer (source) may not contain any conduit or other open connections.
4. A 4 feet clearance is required from meter side of meter rack assembly to any obstruction or structure.
5. Customer service equipment may be installed on the meter rack assembly in accordance with all applicable codes. In unincorporated areas, contact company representative for details.
6. Customer provides, installs and maintains the ground rod conductor, #6 Copper minimum and connection to a ground rod. Company reserves the right to refuse installation of service contingent upon observing an unsafe Customer connection.
7. Alternate Design- Customer shall obtain Company approval of any alternate design prior to installation. A Meter Pedestal is an acceptable alternate design. Contact Company Representative for details.

SECTION 500

METERING AND ASSOCIATED EQUIPMENT

500.01 General

Meter sockets shall be provided, installed and maintained by Customer. When the ratings of meter sockets are exceeded, transockets shall be used. Transockets, when required, shall be provided by Company and installed and maintained by Customer. See Drawings, pages 48-55 for conductor, connector and connection details.

500.02 Work on Meter Installations

Only qualified electrical workers are permitted to remove meter seals and work inside meter enclosures. These qualified electrical workers must contact the Company Electrician Contact line: 1.800.518.2374 and provide information as indicated inside the front cover BEFORE removing self-contained meters and disconnecting power*. Failure to call BEFORE performing work may result in fees applied to install new Company seal(s) and to inspect Company metering equipment. See 100.04.03, page 12.

***Note: Only Oncor may remove 480V self-contained meters or disconnect power to transockets. See 500.06.11, page 46.**

500.03 Sequence of Connecting Facilities

The standard sequence for connecting equipment to Company's existing delivery system facilities is as follows:

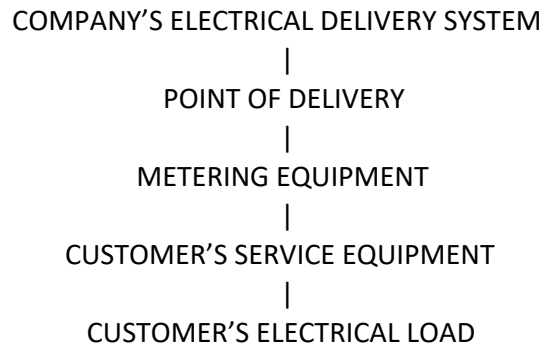

A sequence of facilities other than illustrated here may be done only with prior written approval of the Company.

METERING AND ASSOCIATED EQUIPMENT (cont'd)

500.04

Location of Meter

Consistent with good utility practice, a meter and its associated equipment shall be installed in a location that facilitates the provision of safe and reliable delivery service and accurate measurement and that provides clear working space on all sides. **The center of the socket opening shall be not less than four feet and not more than six feet above the finished grade.** All meter locations should be as near as possible to the point of delivery. The Company shall have direct, unobstructed access to all meter locations. Meter locations likely to become obstructed in the future shall be avoided. **The Company's electrical delivery system and the metering equipment shall be located outside the building.** If the Customer requires a location other than outside the building or if service conductor and conduit must pass under permanent structures, foundations or structure slabs, the Customer shall install and own the electric service conductors from a Company designated point of delivery outside of the building (either secondary transformer terminals or service enclosure) to the metering equipment location. See Drawings, pages 48-55 for typical Point of Delivery (POD) locations. Metering equipment locations other than outside the building are nonstandard and require Company approval prior to installation of the meter.

Transockets and unlicensed meter sockets are not to be installed on Company poles. This applies to both overhead and underground services. See 100.04.02, page 12. License agreements do not allow metering equipment to be installed on Company poles if licensee utilization equipment is not on the same Company pole.

500.05

Meter Work Space

Sufficient space in front of, above, below and on each side of meter sockets, service enclosures, meter packs and transockets is necessary for work space for connecting and the reading of meters. No obstruction shall be within four feet in front of the meter. See NEC Article 110.26 for working spaces.

500.06

Meter Sockets

The Customer will provide, install, and maintain self-contained meter sockets. Transockets, when required, will be provided by Company and installed and maintained by Customer. These sockets are to be used exclusively for Company metering. The Company reserves the right to refuse service if the incorrect socket is installed or if the socket is not wired correctly. **Each connector provided in the meter socket is rated for a single aluminum or copper conductor. The number of Customer conductors shall not exceed the number of connectors (shall not double lug).** See Table 5-C, pages 58-61 for list of approved meter sockets. Aluminum conductors require wire brushing to remove oxide film and an application of oxide inhibitor immediately before installation. **Customer must permanently mark EACH meter socket at multimeter locations as per 500.11, page 47.**

METERING AND ASSOCIATED EQUIPMENT (cont'd)

500.06.01 **Meter Socket Ratings**

Meter sockets are specified by their continuous current rating and are designed for short term (three hours or less) overloads of 125%. Electrical panels are specified by their maximum rating and any continuous loads (three hours or more) are limited to 80% of this maximum. A 320 ampere meter socket has a continuous rating of 320 amperes and a maximum rating of 400 amperes. A 400 ampere panel has a maximum rating of 400 amperes and a continuous rating of 320 amperes. Even though these two items are referred to by different numbers, their capabilities are identical and a 320 ampere socket is adequate to serve a 400 ampere panel.

500.06.02 **Ganged Meter Socket Assemblies**

Ganged meter socket assemblies are for multi-family residential installations and are 120/240 V, three-wire, single-phase. Each of the ganged meter socket assemblies must be clearly and permanently marked to indicate each location to be served prior to the connection of service. See 500.11, page 47. For typical dimensions, examples of layouts, and terminal configurations, refer to Table 5-C, pages 58-61 and Figure 5-F, page 67.

500.06.03 **Meter packs**

Meter packs for multi-family residential and Secondary Service installations will be subject to approval by Company. Where the Company owns the service lateral conductors to main circuit breaker meter packs, Company will only connect to those main circuit breakers with external connectors and not directly to main circuit breakers. Each meter socket must be clearly and permanently marked prior to connection of service as indicated in 500.11, page 47. **Contact Company for approval of meter packs prior to letting bids and installing equipment.** It is the Customer's responsibility to determine local code requirements concerning meter packs with main switches or main circuit breakers prior to installing equipment. **All front panels shall have provisions for Company locks. See Figure 4-D, page 40.**

500.06.04 **Line-side (Source) Connections**

All self-contained meter sockets require the line-side conductors to be connected to the top meter socket terminals. Load-side conductors always connect to the bottom meter socket terminals and must exit below the meter through the lower sides, back or bottom except when utilizing the approved meter socket breaker combo or the round socket on Table 5-C, page 54 for temporary underground service. For overhead services the line-side conductors must enter from the top half of the socket. Approved sockets for underground services provide additional width to allow the line-side conductors to enter the bottom of the socket and to be routed to the top terminals. For transocket connections, see 500.06.11, page 46.

METERING AND ASSOCIATED EQUIPMENT (cont'd)

- 500.06.05 **Meter Sockets - Secondary Service Less than 200 Amperes**
200 ampere meter sockets specified for use on Secondary Service Customers are equipped with a lever operated bypass mechanism to permit installation and removal of meters without causing interruption of service. Use of this socket is primarily intended to prevent disruption of service to loads typically found in many Secondary Service accounts. However in special cases, a non-lever bypass socket (similar to Company number 301399 and 301401) may be substituted instead. **Contact Company prior to acquiring and installing meter socket. For more information see Table 5-C, pages 58-61 for list of approved meter sockets.** When utilizing meter packs to serve Secondary Service Customers, lever operated bypass mechanisms are required for each individual meter socket. **Contact Company for approval of meter packs prior to letting bids and installing equipment.**
- 500.06.06 **Power Leg for 240 V Delta Service**
The phase that is commonly called the Power Leg (“high leg”, “freak leg”, or “wild phase”) shall always be connected to the right-hand meter socket terminals including prewired transockets and shall be effectively identified in accordance with NEC 230.56 (marked by orange tape or paint). In other locations, such as service enclosures, disconnects, etc., the Power Leg is connected to the center terminal. See Figure 5-K, page 72.
- 500.06.07 **Underground Delta - Meter Socket and Transocket Case Ground Requirements**
In addition to grounding requirements established by the National Electrical Code and local ordinances, the metal enclosures of meter sockets and transockets shall be connected to an eight foot auxiliary ground rod located within sight of and as close as practicable to the meter socket. These additional grounding requirements are the responsibility of the Customer. Customer must remove any ground jumpers or ground straps on center (unmetered) phase of meter socket or transocket to ensure the service remains ungrounded. See Table 5-C, pages 58-61.
- 500.06.08 **Company - Customer Responsibility**
See Drawings, pages 48-55.
- 500.06.09 **Meter and Socket Application Guide**
See Table 5-C, pages 58-61 or visit: oncor.com/EN/Pages/Commercial-Metering.aspx
- 500.06.10 **Meter Socket Connections and Voltages**
See Figures 5-G through Figure 5-K, pages 68-72 for details.

METERING AND ASSOCIATED EQUIPMENT (cont'd)

500.06.11 Transockets

When the voltage and/or current limitations of a self-contained meter socket are exceeded, the transocket is standard equipment for installations 480 V and less (see Table 5-C, pages 58-61 for maximum socket ampacity). Transockets are not interchangeable; it is critical that the correct transocket be installed for each application. **Factory installed lugs are NOT to be replaced or removed. Damaged lugs may require replacement of Transocket (See Company for details).** Company will determine the need for a transocket and will provide the correct transocket. Customer will install transocket and maintain Customer connections in the transocket. Transocket can be wired for top or bottom feed. Grounding conductor can pass through the transocket but **shall not** terminate within. If service is underground, the line conductors must enter the bottom of the transocket and connect to the bottom terminals. For overhead service, the line conductors will enter the top of the transocket and connect to the top terminals. Load conductors will always exit opposite the line conductors; no conductors will be allowed to cross inside the transocket. The conductor entrance and exit location notes of Figure 5-D, page 65 must be followed. Any meter wiring modifications necessary to accommodate source location will be performed by Company prior to the meter installation. **Only Company authorized personnel may remove a meter from a transocket. See inside the front cover for more details.**

Caution: removing the meter from a transocket does not disconnect the service.

500.06.12 Transocket Configurations and Connection Details

See Figure 5-D, pages 62-65.

500.07 Instrument Transformers (IT, CT and VT)

For installations requiring instrument transformers (IT), the standard methods of metering are (1) the transocket or (2) metering at the pad transformer with the IT installed in the pad transformer. When the Customer's service requirements exceed the capacity of the transocket and metering at the pad transformer is not feasible, the preferred metering method is to use IT installed in a Company approved enclosure. Company will provide the IT and, when necessary, the enclosure. Customer may be required to install the enclosure and IT. If IT should need to be replaced, Customer may be required to install the Company provided replacement IT. Where IT's are installed in Customer owned switchgear, the Customer shall be responsible for having the switchgear manufacturer install acceptable IT's. Customer must contact Company to determine ratio, burden, and accuracy of requirements and must provide certified test reports of IT performance.

METERING AND ASSOCIATED EQUIPMENT (cont'd)

- 500.08 Service Enclosures (Distribution Can, Terminal Box, Tap Can, Connection Box)**
Company may require the use of service enclosures for certain configurations of multiple meters. Company will specify the appropriate enclosure. Use of gutters or troughs as connection enclosures is not allowed. Service enclosures will be provided by Company and installed by Customer. **Customer is responsible for all metering equipment and ensuring service switches are installed on the load side of service enclosures.** Customer will install service enclosure and maintain Customer connections in the service enclosure. Refer to definition 100.01.38, page 8. For details see: Figure 3-H, page 32; Figure 4-C, page 39; Figure 5-E and Table 5-E, page 66; and Figure 5-F, page 67.
- 500.09 Pad mounted Secondary Enclosures (Connection Enclosures: 36 inch x 36 inch x 36 inch see Company TSN 463082 & 54 inch x 54 inch x 54 inch see Company TSN 463081)**
Company shall require the use of secondary enclosures for installations where the Customer is installing a number of conduits and conductors in excess of the maximum quantity allowed for the transformer per Company Standards. See Company Representative for details. Company Representative will specify the appropriate enclosure. Contact Company for additional design options. For reference see Drawings, pages 58-61 and Oncor Distribution Design Specification DDS-4 at www.oncor.com. All metering equipment and service switches are installed on the load-side of secondary enclosures. See definition 100.01.43, page 8.
- 500.10 Totalizing Multiple Points of Delivery (POD)**
Meters serving installations not considered a single point of delivery shall not be totalized.
- 500.11 Meter Socket Identification at Multimetered Locations**
Meter sockets to multi-metered locations shall be clearly and permanently marked on both the exterior and interior of the meter socket to indicate each apartment number or location served.
- Exterior:** Placards engraved or stamped, 12 gauge (2.0 millimeter) minimum thickness stainless steel, aluminum or brass placards shall be used on the exterior of the meter socket. Each placard shall be permanently affixed with an exterior rated adhesive to the lower front of the meter socket. Screws and rivets may not be used to attach placards to meter sockets. Placards may vary in size; the minimum is .25 inch tall letters/numbers.
- Interior:** Permanent marker or other acceptable method shall be used to mark the apartment number or location on the inside of the meter socket (at a location other than the cover) where it can be easily read. See Figure 4-D, page 40.
- 500.12 Service to a Recreational Vehicle (RV) Park**
Per the Company tariff, an RV is not considered an Individual Private Dwelling and cannot be placed on the Residential Rate. RV parks shall not be provided meters to each RV pad site regardless of the period of time RVs are located at an RV park whether permanent residence or not. RVs are to be treated differently than mobile home parks. RVs are not mobile homes and cannot be served in the same manner.
- Company practice is to design & supply service to RV parks with a negotiated minimal number of points of delivery. These points should be based on load and/or voltage drop on Customer owned facilities. Each point of delivery is setup under the Secondary Rate. The owner of the park still has the option to provide their own meters to individual pad sites if they so desire, by adhering to Chapter 184, Subchapter C of the Texas Utilities Code.

COMPANY - CUSTOMER RESPONSIBILITY

SINGLE METER LOCATIONS - OVERHEAD SERVICE AND UNDERGROUND SERVICE FROM OVERHEAD SOURCE

Overhead Service

**Single-Phase Secondary Service
less than 20 kW or residential**

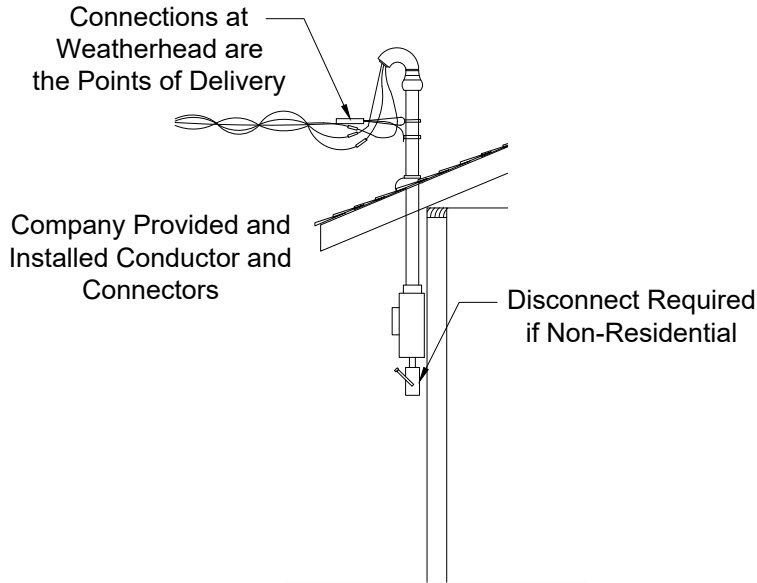

Overhead Service

**Single-Phase or Three-Phase Secondary Service
greater than or equal to 20 kW**

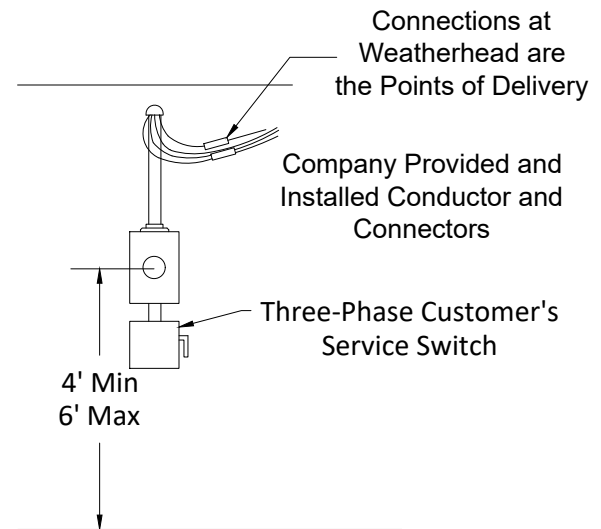

Underground Service from Overhead Secondary or Overhead Transformation

**Single-Phase Secondary Service
Less than 20 kW or Residential
and/or**

**Single-Phase or Three-Phase Secondary
Service Greater than 20 kW or Equal to 20 kW**

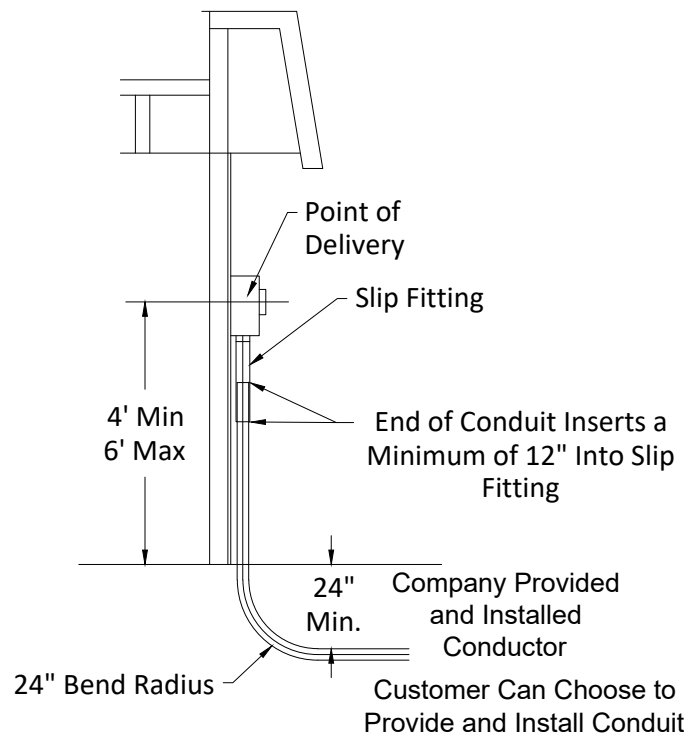

COMPANY - CUSTOMER RESPONSIBILITY

SINGLE METER LOCATIONS - UNDERGROUND SERVICE FROM UNDERGROUND SECONDARY OR PAD MOUNTED TRANSFORMATION

Underground Service from Underground Secondary or Pad Mounted Transformation

Single-Phase Secondary Service less than 20 kW or residential

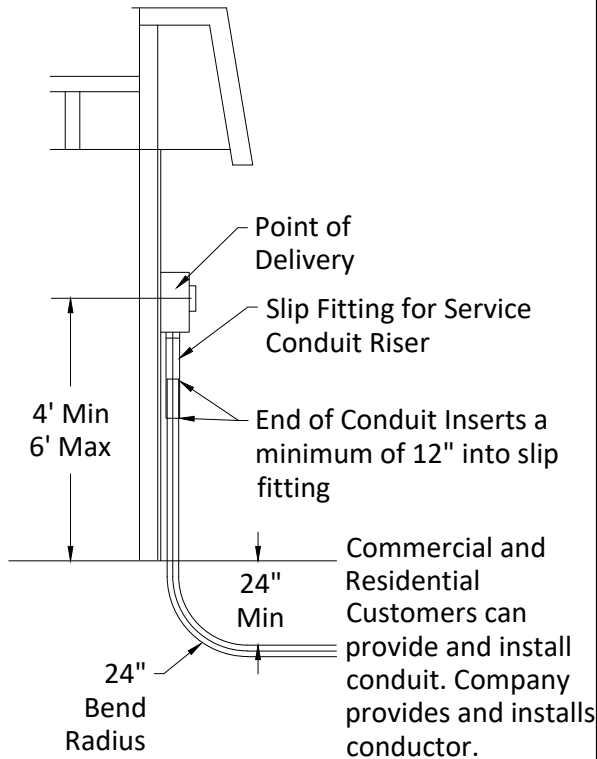

Notes:

1. The Point of Delivery (P.O.D.) is the point at which electric power and energy leaves the Company delivery system; see 100.01.31, page 7. P.O.D. locations other than those indicated may be designated by Company. In such cases, ownership of service conductors shall be permanently marked.
2. Customer installed raceway is permitted or required as specified in 400.02, page 34.
3. The Customer is responsible for making all physical connections on the load side of P.O.D. All conductors and connectors on the load side of the P.O.D. are provided, installed, and maintained by the Customer. See Appendix A, (NEMA 2-hole) page 80 or Appendix B, (NEMA 1-hole) page 81 for specification of approved connectors installed in Company metering and Company connection enclosures and in Company pad mounted equipment.
4. The Company shall make all physical connections at the source side terminals at the P.O.D. All connectors placed on Company conductors are to be supplied and installed by Company. Customer provides and installs terminations on Customer conductors. For Overhead Primary Metering - Company will attach the Customer conductors to Company Dead End Insulator and install jumper from Primary Metering Equipment. For Underground pad mounted Primary Metering - Customer provides and installs terminations on Customer conductors. Company attaches terminations to Company equipment and energizes the conductors.

Underground Service from Underground Secondary or Pad Mounted Transformation using Pad Mounted Secondary Enclosure

Single-Phase or Three-Phase Secondary greater than or equal to 20 kW

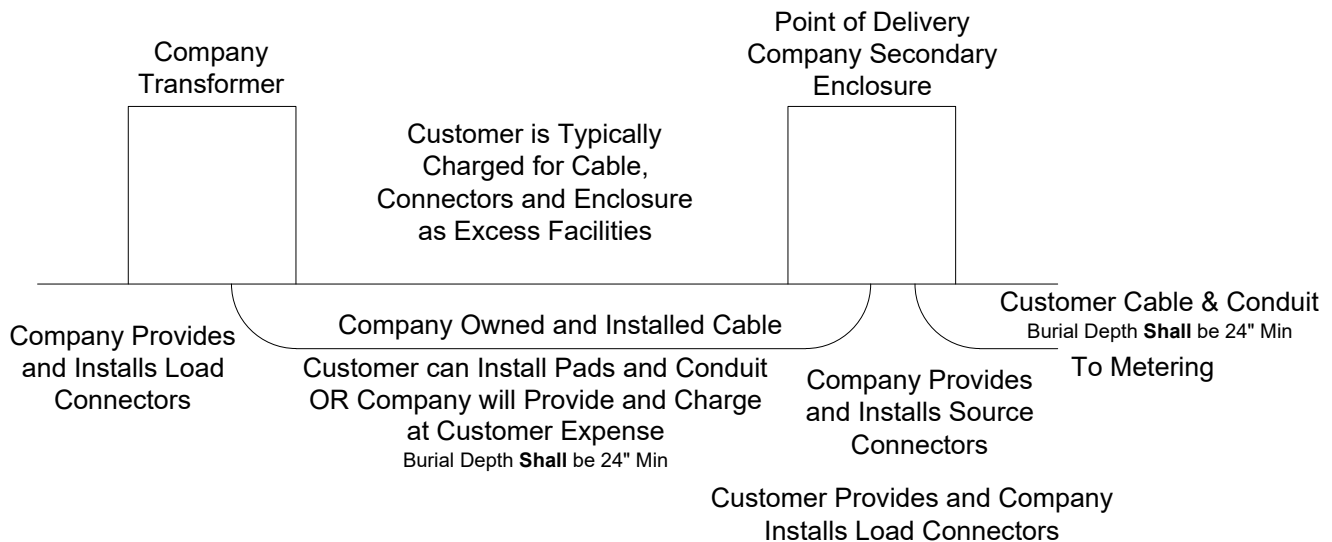

COMPANY - CUSTOMER RESPONSIBILITY

SINGLE METER LOCATIONS - OVERHEAD PRIMARY SERVICE

Primary Metering greater than 150A

Point of Delivery

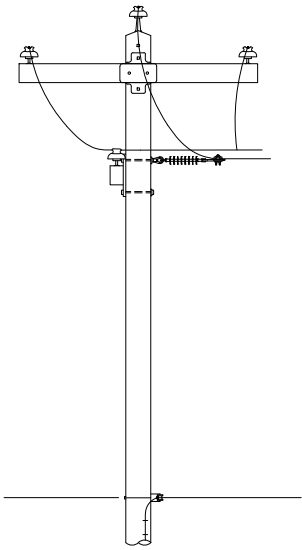

Oncor Mainline Pole

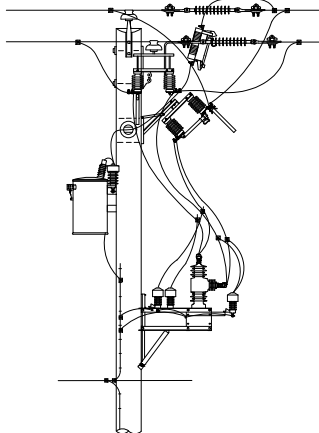

Oncor Electronic Recloser Pole

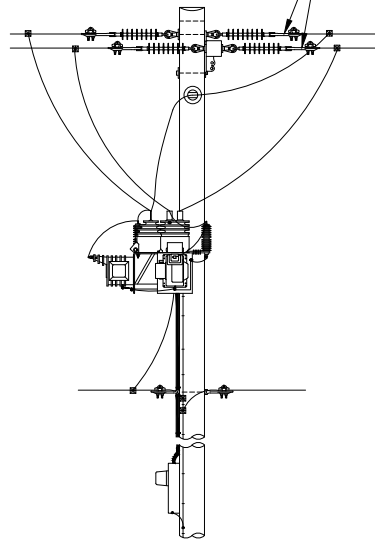

Oncor PME Pole

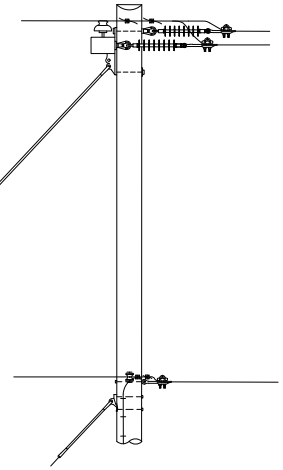

Customer's Deadend Pole

Note:
Meter base shall be installed according to company guidelines and oriented such that it has safe and easy accessibility.

Primary Metering less than 150A

Points of Delivery

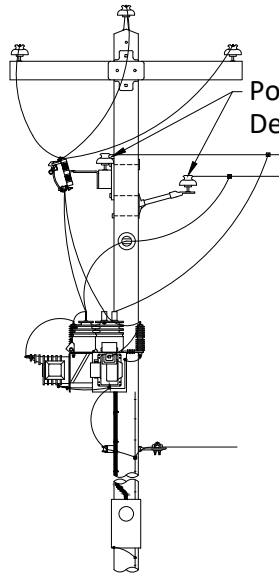

Oncor Mainline Pole with PME and Line Fuse

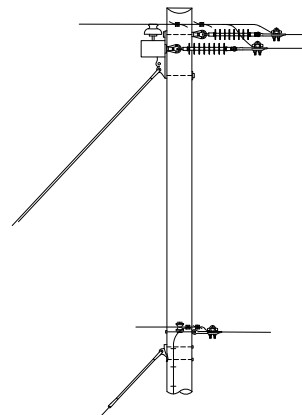

Customer's Deadend Pole

Note:
Meter base shall be installed according to company guidelines and oriented such that it has safe and easy accessibility.

COMPANY - CUSTOMER RESPONSIBILITY

SINGLE METER LOCATIONS - OVERHEAD AND UNDERGROUND PRIMARY VOLTAGE SERVICE

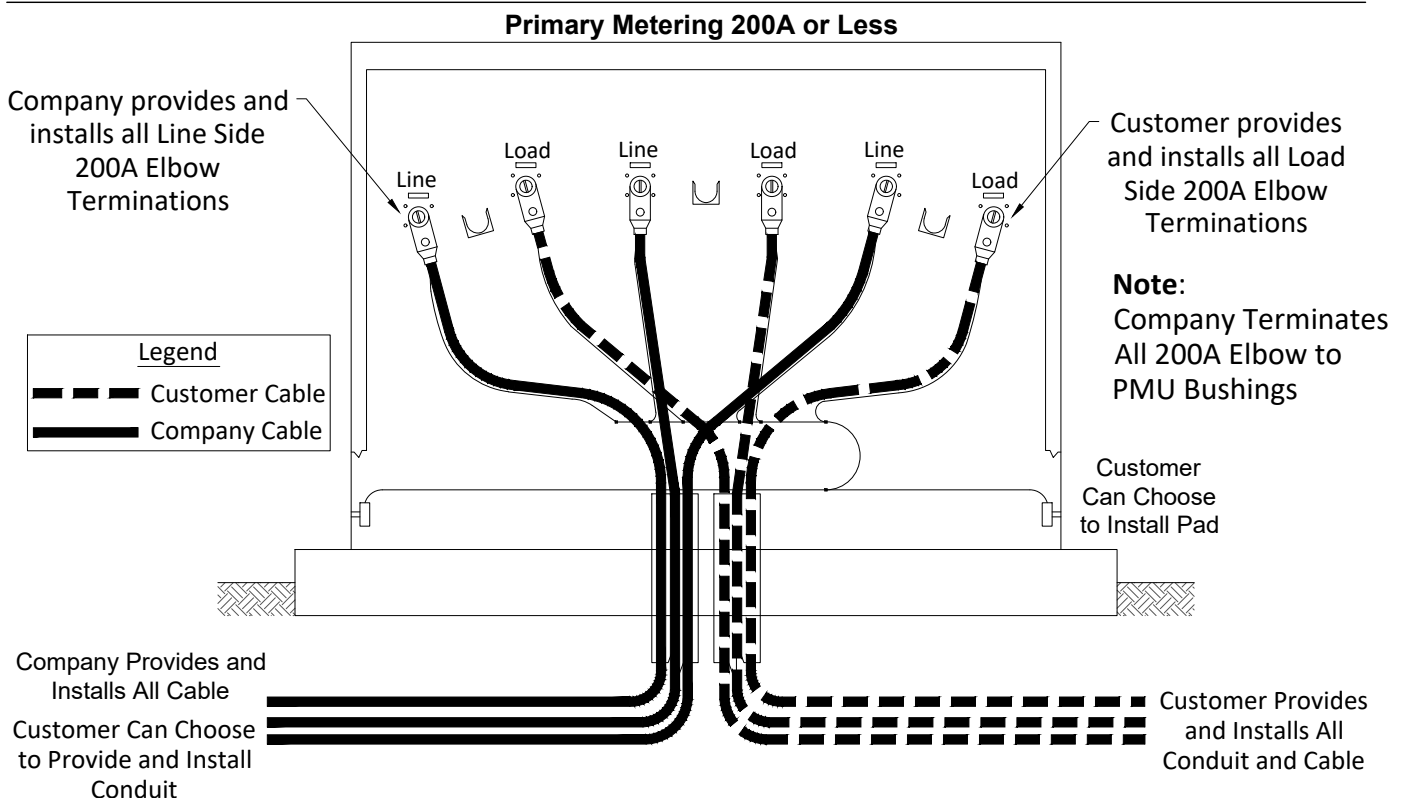
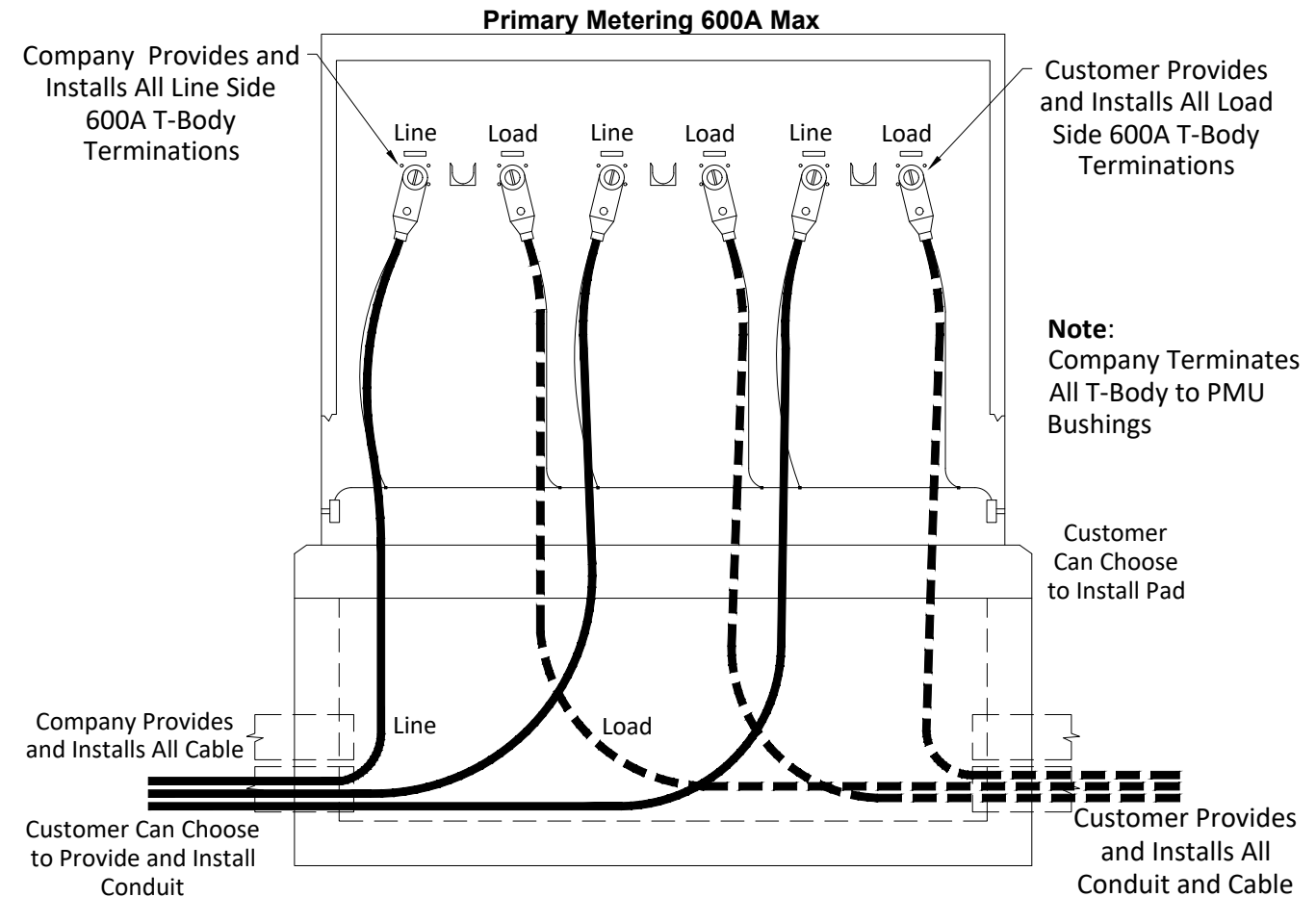

COMPANY - CUSTOMER RESPONSIBILITY

MULTIPLE METER LOCATIONS - OVERHEAD SERVICE

Overhead Service (Non-Residential or Multi-Family) Three Meters or Less Per Service Lateral

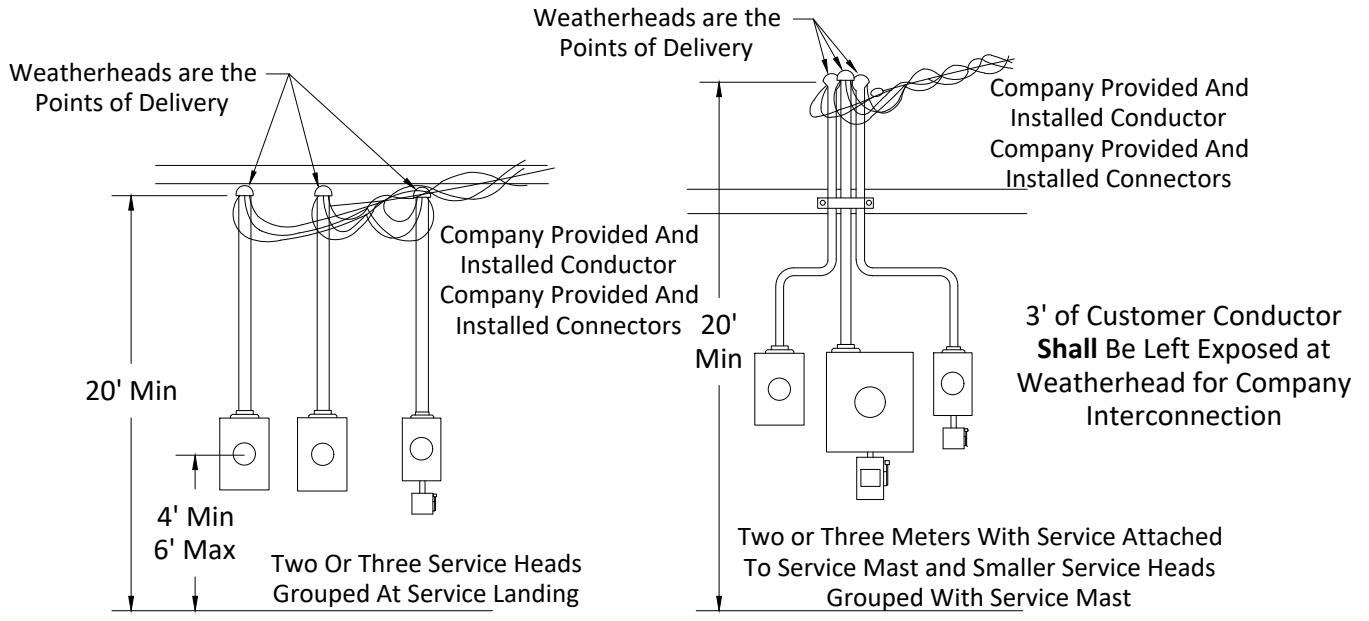

Overhead Service (Non-Residential or Multi-Family) Four Meters or More Per Service Enclosure

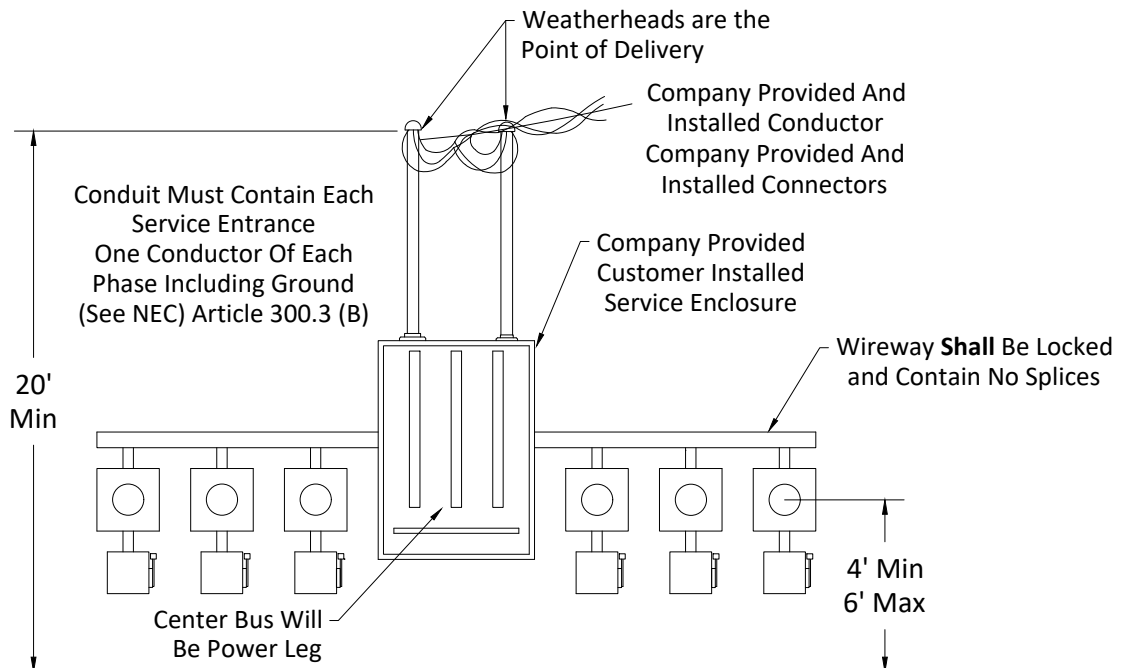

COMPANY - CUSTOMER RESPONSIBILITY

MULTIPLE METER LOCATIONS - UNDERGROUND SERVICE TO MULTI-FAMILY RESIDENTIAL

Underground Service to Multi-Family Residential Residential, 6 Meters or Less without Service Enclosures (Ganged Multi-Metering)

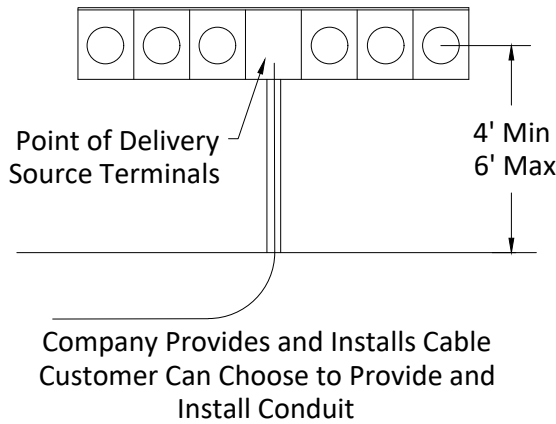

Underground Service to Multi-Family Residential Residential, 6 Meters or Less with Service Enclosures

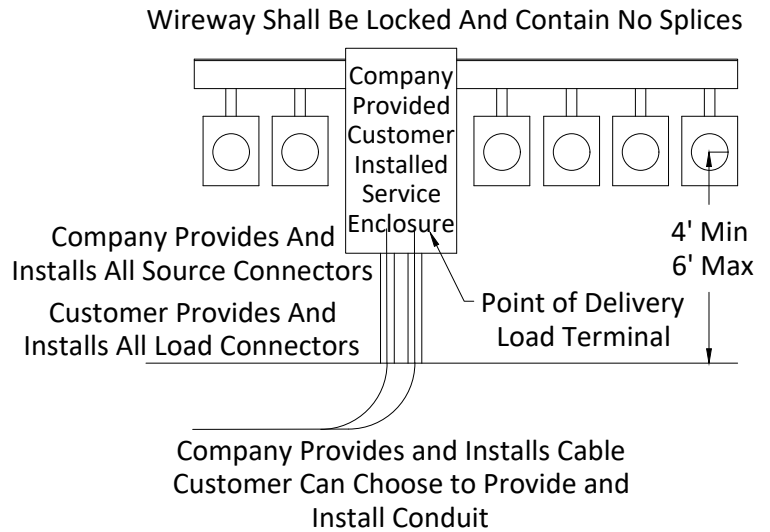

Underground Service to Multi-Family Residential Residential, 7 Meters or More using Meter pack

Customer Provides and Installs The Meter pack With Prior Company Approval

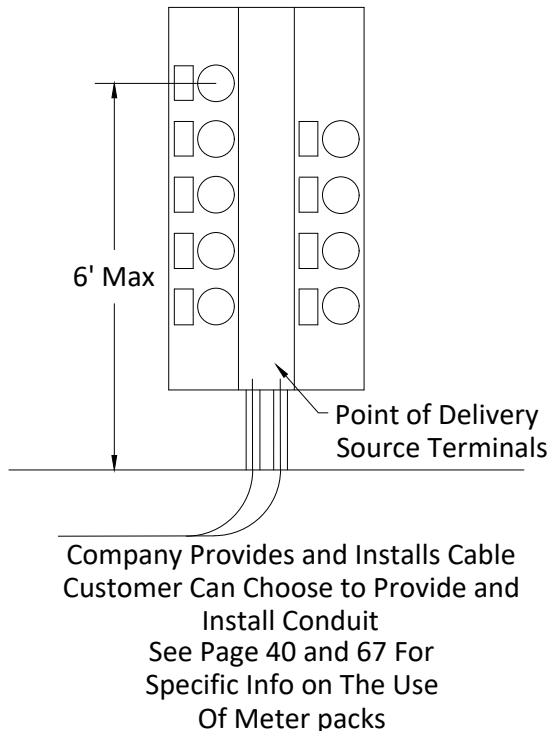

Notes:

1. The Point of Delivery (P.O.D) is the point at which electric power and energy leaves the company delivery system; see 100.01.31, page 7. P.O.D. locations other than those indicated may be designated by Company. In such cases, ownership of service conductors shall be permanently marked.
2. Customer installed raceway is permitted or required as specified in 400.02, page 34.
3. Contact Company for approval of meter packs prior to letting bids and installing equipment.
4. If 7 meters or more are served, a service enclosure may be used or Company may run multiple service laterals, if permitted by local code.
5. The Customer is responsible for making all physical connections on the load side of the P.O.D. All conductors and connectors on the load side of the P.O.D. are provided, installed, and maintained by the Customer. See Appendix A, (NEMA 2-hole) page 80 and Appendix B, (NEMA 1-hole) page 81 for approved connector specifications for use with metering and connection enclosure and in pad mounted equipment.
6. The Company shall make all physical connections at the source side terminals at the P.O.D. All connectors placed on Company conductors are to be supplied and installed by the Company.
7. The Company will provide and install the source to P.O.D. conductor for Multi-Family Residential with the standard service voltage of 120/240V. The Conductor for all other requested voltage to Multi-Family Residential will be the customers responsibility.

COMPANY - CUSTOMER RESPONSIBILITY

MULTIPLE METER LOCATIONS - UNDERGROUND SECONDARY SERVICE (NON-RESIDENTIAL)

Underground Service (Non-Residential) Service From Overhead Secondary or Transformer Three-Phase Served from Overhead Transformer or Single-Phase Less Than 20 kW

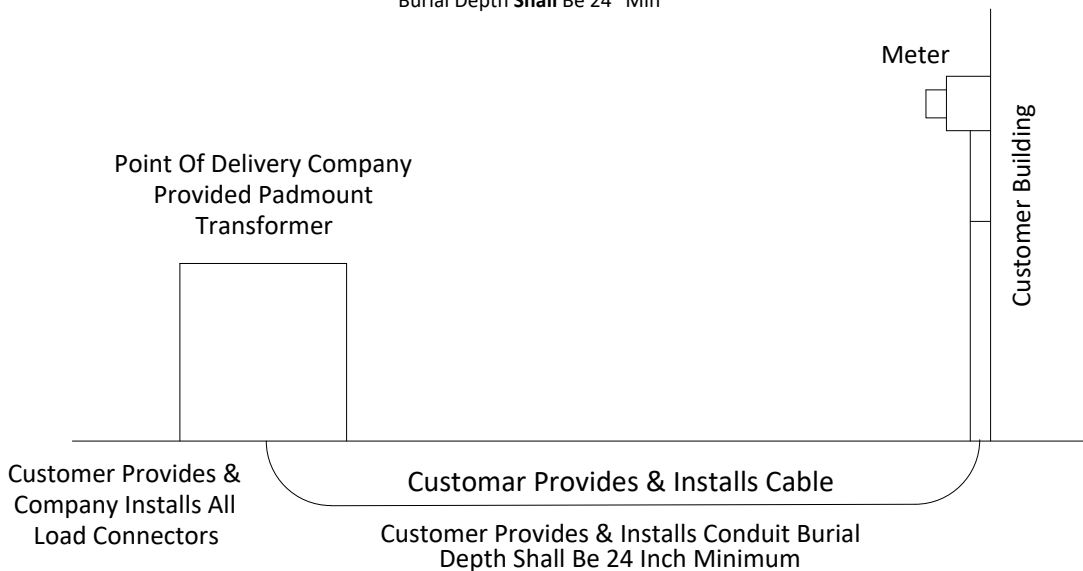
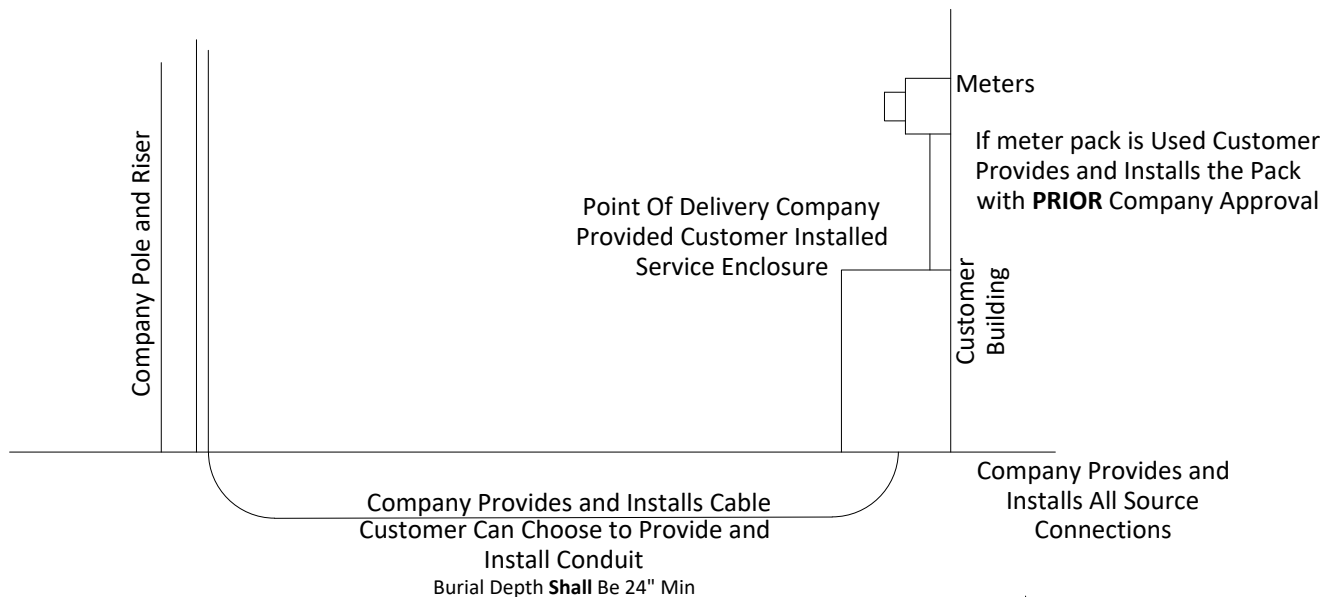

Three Phase Served From Padmounted Transformation
Or Underground Secondary -and/or-
Single Phase Greater Than Or Equal To 20 kW Served
From Padmounted Transformer Or From Underground
Secondary

COMPANY - CUSTOMER RESPONSIBILITY

MULTIPLE METER LOCATIONS - UNDERGROUND SECONDARY SERVICE (NON-RESIDENTIAL)

Underground Secondary (Non-Residential) Service from Underground Secondary or Pad Mount Transformer Using Pad Mounted Secondary Enclosure

Three-Phase Served from Pad Mounted Transformer or Underground Secondary - and/or - Single-Phase Greater Than or Equal to 20 kW Served From Pad Mounted Transformer or From Underground Secondary.

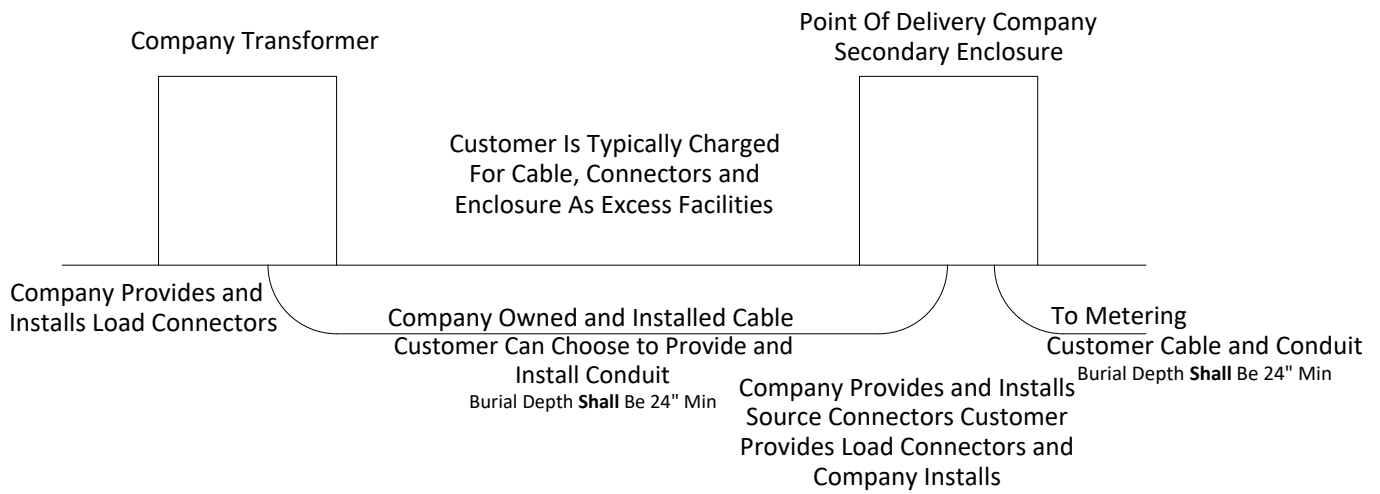

Underground Secondary (Non-Residential) Service from Pad Mounted Transformer

Three-Phase served from Pad Mounted Transformer or Underground Secondary - and/or - Single-Phase greater than or equal to 20 kW served from Pad Mounted Transformer or from Underground Secondary.

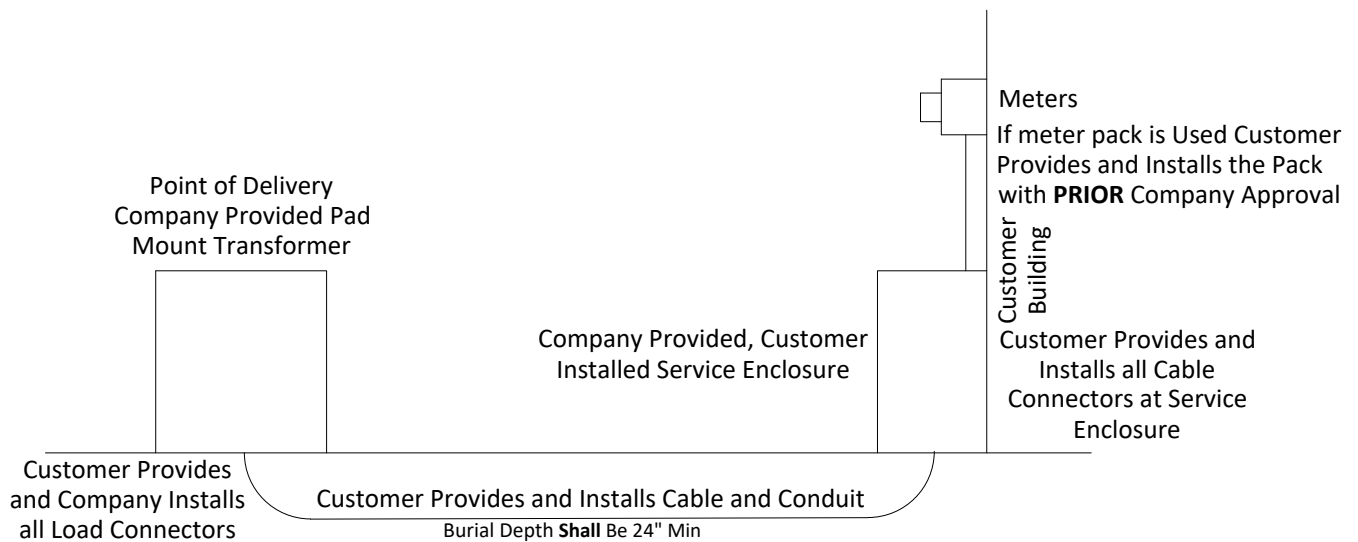

METER AND SOCKET APPLICATION GUIDE

TABLE 5-C

		APPLICATION					METER SOCKET			MAX HUB SIZE	MAX # CONDUCTORS MIN/MAX CONDUCTORS SIZES, TYPICAL DIMENSIONS **
WIRES	PHASE	VOLTS	SERVICE TYPE	MAX AMPS	INSTALLATION TYPE	ITEM NO.	MANUFACTURER*	PART NUMBER*			
3	1	120/240	Temporary Service Only	0-125	Self Contained UG	902484	Cutler Hammer (EATON)	CHR2G2GKGSU	2"	Source: One # 14 - # 1/0 Size: 30" X 9.5" X 6.8" Note: equipped with circuit breakers and receptacles	
2	1	120 or 240	Temporary OH & UG Service	0-60	Self Contained OH or UG Temporary***	312720	Brooks Milbank	603-3185-E AP2300-03	One 1"	Source: One # 12 - # 1/0 Load: One # 12 - # 1/0 Size: 7" Diameter (Round)	
2	1	120 or 240	Secondary Service OH Only	0-60	Self-Contained OH Only	312720	Brooks Milbank	603-3185-E AP2300-03	One 1"	Source: One # 12 - # 1/0 Load: One # 12 - # 1/0 Size: 7" Diameter (Round)	
2	1	120 or 240	Residential Or Secondary Service	0-150	Self-Contained OH Only	301399	Cutler-Hammer Durham Talon/Landis & Gyr Midwest Electric Milbank Talon/Siemens Square D	UT-RS502B-CH UT-RS502B UAT314-OG UT-RS502B-MEP U7262-RL SUAT314-OG UT-RS502B-SQD	One 2.75"	Source: One # 2 - 250 Load: One # 2 - 250 Size: 8.5" X 15" X 3.25" Note: 2W Service Is Limited To 100 A	
2	1	480	Secondary Service	0-200	Mini Transocket OH or UG	320797	Durham	105777A	One 3"	Source: One # 6 - 250 Load: One # 6 - 250 Size: 13" X 24" X 9"	
3	1	120/240	Secondary Service Or Temporary	0-60	Self-Contained OH Only	312720	Brooks Milbank	603-3185-E AP2300-03	One 1"	Source: One # 12 - # 1/0 Load: One # 12 - # 1/0 Size: 7" Diameter (Round)	
3	1	120/240	Residential	0-150	Self-Contained OH Only	301399	Cutler-Hammer Durham Talon/Landis & Gyr Midwest Electric Milbank Talon/Siemens Square D	UT-RS502B-CH UT-RS502B UAT314-OG UT-RS502B-MEP U7262-RL SUAT314-OG UT-RS502B-SQD	One 2.75"	Source: One #2- 250 Load: One # 2 - 250 Size: 8.5" X 15" X 3.25"	
3	1	120/240	Secondary Service	60-200	Self-Contained OH or UG	312727	Cutler-Hammer Durham Talon/Landis & Gyr Midwest Electric Milbank Talon/Siemens Square D	UT-E4213B-CH UT-H4213B 40404-025 UT-H4213B-MEP U9801-XL S40404-025 UT-H4213B-SQD	One 2.75"	Source: One # 6 - 350 Load: One # 6 - 350 Size: 13" X 19" X 5" Note: Equipped With Lever Bypass	
3	1	120/240	Residential	150-200	Self-Contained OH or UG	301401	Cutler-Hammer Durham Talon/Landis & Gyr Midwest Electric Milbank Talon/Siemens Square D	UT-RS212B-CH UT-RS212B UAT417-XG UT-RS212B-MEP U7040-XL SUAT417-XG UT-RS212B-SQD	One 2.75"	Source: One # 2 - 250 Load: One # 2 - 250 Size: 11" X 14" X 5"	

* Manufacturer name and part number subject to change

** Actual dimensions will vary

***Exception made for use with underground temporary service

METER AND SOCKET APPLICATION GUIDE (cont'd)

TABLE 5-C

APPLICATION					METER SOCKET				MAX HUB SIZE	MAX # CONDUCTORS MIN/MAX CONDUCTORS SIZES, TYPICAL DIMENSIONS **
WIRES	PHASE	VOLTS	SERVICE TYPE	MAX AMPS	INSTALLATION TYPE	ITEM NO.	MANUFACTURER*	PART NUMBER*		
3	1	120/240	Residential	0-200	Self-Contained OH or UG	323754	Cutler-Hammer Durham Midwest Electric Square D	UT-RS213-8B-CH UT-RS213-8B UT-RS213-8B-MEP UT-RS213-8B-SQD	One 2.75"	Source: One 1/0 - 350 Load: Two 1/0 - 250 Size: 13" X 20" X 5"
3	1	120/240	Residential Meter Socket/Breaker Combo Unit	0-200	Self-Contained OH or UG	915092	Siemens	MC0816B1200RTH	Small	Source: One #6 - 350 Size: 21.06" X 23.5" X 5.25" 200A Main Breaker 8 Circuit Load Center
3	1	120/240	Residential Meter Socket/Breaker Combo Unit	0-200	Self-Contained OH or UG	915092	Siemens	MM0202B1200R	Small	Source: One #6 - 250 Size: 16.51" X 17.06" X 5.25" 200A Main Breaker
3	1	120/240	Residential Meter Socket/Breaker Combo Unit	0-200	Self-Contained OH Only	915092	Milbank	U5842-RL-200	Small	Source: One #6 - 350 Load: One #1 - 300 Size: 8" X 30" X 4.125" 200A Main Breaker
3	1	120/240	Residential Meter Socket/Breaker Combo Unit	0-200	Self-Contained OH or UG	915092	Square D	RC200S	Small	Source: One #6 - 300 Size: 19.58" X 18.23" X 4.67" 200A Main Breaker
3	1	120/240	Residential Or Secondary Service	200-320	Self-Contained OH or UG	301402	Cutler-Hammer Durham Talon/Landis & Gyr Midwest Electric Milbank Milbank Talon/Siemens Square D	UT-H4336-9T-CH UT-H4336-9T 48104-02 UT-H4336-9T-MEP U1797-O-K3L-K2L U4363-R S48104-02 UT-H4336-9T-SQD	One 4"	Source: One # 2 - 600 Load: Two # 6 - 350 Size: 15" X 37" X 6" Note: Equipped With Lever Bypass
3	1	120/240	Residential Or Secondary Service	320-600	Med Transocket OH or UG	301417	Milbank Durham	S2690-XT 1004790A	Two 4"	Source: Two # 2 - 600 Load: Two # 2 - 600 Size: 18" X 30" X 12"
3	1	120/240	Residential Or Secondary Service		Maxi- Transocket OH or UG	302775	Milbank Durham	S3487-4X 1005014A	Four 4"	Source: Four # 2 - 600 Load: Four # 2 - 600 Size: 30" X 42" X 14"

* Manufacturer name and part number subject to change

** Actual dimensions will vary

METER AND SOCKET APPLICATION GUIDE (cont'd)

TABLE 5-C

APPLICATION					METER SOCKET				MAX HUB SIZE	MAX # CONDUCTORS MIN/MAX CONDUCTORS SIZES, TYPICAL DIMENSIONS **
WIRES	PHASE	VOLTS	SERVICE TYPE	MAX AMPS	INSTALLATION TYPE	ITEM NO.	MANUFACTURER*	PART NUMBER*		
3	1	120/240	Mobile Home Single Position	0-200	Self- Contained UG Only	913622	Milbank	U5138-O-XXX-NHB (XXX = 100S or 200S for max socket amps)	N/A	Source: One # 6 - 250 Load: Prewired - 250 Size: 10" X 56" X 10.25" Note: Use With pad-mount kit K5035 5TH Jaw order kit #K5T (120/208)
3	1	120/240	Mobile Home 2 Gang Vertical	0-200	Self- Contained UG Only	913623	Milbank	U5139-O-XXX-NHB (XXX = 100S or 200S for max socket amps)	N/A	Source: One # 6 - 350 Load: Prewired - 250 Size: 10" X 56" X 16.06" Note: Use With pad-mount kit K5035 5TH Jaw order kit #K5T (120/208)
3	1	120/240	Pedestal Secondary Service	0-200	Self-Contained UG Only	913624	Milbank	U6435-O-XXX-10GR (XXX = 100 through 200 for max socket amps and S or P for breaker controls layout)	N/A	Source: One # 6 - 350 Load: As specified on Circuit Breaker Size: 10" X 56" X 10.25" Note: Equipped With Lever Bypass & Use With K6448 pad mount kit 5TH Jaw order kit #K3865
3	1	120/240	Apartment 2 Gang Horizontal	0-150	Self- Contained OH or UG	301408	Cutler-Hammer Durham Talon/Landis & Gyr Midwest Electric Milbank Talon/Siemens Square D	UT-2R5332B-CH UT-2R5332B UA2313-OG UT-2R5332B-MEP U1252-X SUA2313-OG UT-2R5332B-SQD	One 2.75"	Source: One # 2 - 350 Load: One # 2 - 250 Per Position Size: 25" X 14" X 6"
3	1	120/240	Apartment 3 Gang Horizontal	0-150	Self- Contained OH or UG	301403	Cutler-Hammer Durham Talon/Landis & Gyr Midwest Electric Milbank Milbank Talon/Siemens Square D	UT-3R5332B-CH UT-3R5332B UA3313-OG UT-3R5332B-MEP U9353-XL U1253-XL SUA3313-OG UT-3R5332B-SQD	Two 2.75"	Source: One # 2 - 350 Load: One # 2 - 250 Per Position Size: 33" X 14" X 5"
3	1	120/240	Apartment 4 Gang Horizontal	0-150	Self- Contained OH or UG	301404	Cutler-Hammer Durham Talon/Landis & Gyr Midwest Electric Milbank Milbank Talon/Siemens Square D	UT-4R5332B-CH UT-4R5332B UA4313-OG UT-4R5332B-MEP U9354-XL U1254-XL SUA4313-OG UT-4R5332B-SQD	Two 2.75"	Source: One # 2 - 350 Load: One # 2 - 250 Per Position Size: 41" X 14" X 5"

* Manufacturer name and part number subject to change

** Actual dimensions will vary

METER AND SOCKET APPLICATION GUIDE (cont'd)

TABLE 5-C

APPLICATION					METER SOCKET				MAX HUB SIZE	MAX # CONDUCTORS MIN/MAX CONDUCTORS SIZES, TYPICAL DIMENSIONS **
WIRES	PHASE	VOLTS	SERVICE TYPE	MAX AMPS	INSTALLATION TYPE	ITEM NO.	MANUFACTURER*	PART NUMBER*		
3	1	120/240	Apartment 5 Gang Horizontal	0-150	Self- Contained OH or UG	301405	Cutler-Hammer Durham Talon/Landis & Gyr Midwest Electric Milbank Talon/Siemens Square D	UT-5R5352T-CH UT-5R5352T UA5719-KPQG UT-5R5352T-MEP U1255-X SUA5719-KPQG UT-5R5352T-SQD	Two 2.75"	Source: One 2/0 - 500 Load: One # 2 - 250 Per Position Size: 49" X 14" X 5"
3	1	120/240	Apartment 6 Gang Horizontal	0-150	Self- Contained OH or UG	301406	Cutler-Hammer Durham Talon/Landis & Gyr Midwest Electric Milbank Talon/Siemens Square D	UT-6R5392TT-CH UT-6R5392TT UA6719-KPQG UT-6R5392TT-MEP U1256-X SUA6719-KPQG UT-6R5392TT-SQD	Two 2.75"	Source: One 2/0 - 500 Load: One # 2 - 250 Per Position Size: 63" X 15" X 5"
3	1	240/480	Secondary Service	0-200	Mini Transocket OH or UG	320797	Durham	1005777A	One 3"	Source: One # 6 - 250 Load: One # 6 - 250 Size: 13" X 24" X 9"
3	Network	120/208	Residential Or Secondary Service	0-200	Self- Contained OH or UG	301392	Cutler-Hammer Durham Talon/Landis & Gyr Midwest Electric Milbank Talon/Siemens Square D	UT-H5213B-ND-CH UT-H5213B-ND 9804-8592 UT-H5213B-ND-MEP U9581-RXL-QG S9804-8592 UT-H5213B-ND-SQD	One 2.75"	Source: One # 2 - 350 Load: One # 2 - 350 Size: 13" X 19" X 5" Note: Equipped With Lever Bypass
3	3Δ	240	Secondary Service	0-200	Self- Contained OH or UG	301392	Cutler-Hammer Durham Talon/Landis & Gyr Midwest Electric Milbank Talon/Siemens Square D	UT-H5213B-ND-CH UT-H5213B-ND 9804-8592 UT-H5213B-ND-MEP U9581-RXL-QG S9804-8592 UT-H5213B-ND-SQD	One 2.75"	Source: One # 2 - 350 Load: One # 2 - 350 Size: 13" X 19" X 5" Note: Equipped With Lever Bypass
3	3Δ	240	Secondary Service	200-600	Med Transocket OH or UG	301417	Milbank Durham	S2690-XT 1004790A	Two 4"	Source: Two # 2 - 600 Load: Two # 2 - 600 Size: 18" X 30" X 12"
3	3Δ	240	Secondary Service	600-1600	Maxi- Transocket OH or UG	302775	Milbank Durham	S3487-4X 1005014A	Four 4"	Source: Four # 2 - 600 Load: Four # 2 - 600 Size: 30" X 42" X 14"
3	3Δ	480	Oilfield Only	0-200	Self- Contained OH or UG	301392	Cutler-Hammer Durham Talon/Landis & Gyr Midwest Electric Milbank Talon/Siemens Square D	UT-H5213B-ND-CH UT-H5213B-ND 9804-8592 UT-H5213B-ND-MEP U9581-RXL-QG S9804-8592 UT-H5213B-ND-SQD	One: 2.75"	Source: One # 2-350 Load: One # 2-350 Size: 13" X 19" X 5" Note: Equipped With Lever Bypass

* Manufacturer name and part number subject to change

** Actual dimensions will vary

METER AND SOCKET APPLICATION GUIDE (cont'd)

TABLE 5-C

APPLICATION					METER SOCKET				MAX HUB SIZE	MAX # CONDUCTORS MIN/MAX CONDUCTORS SIZES, TYPICAL DIMENSIONS **
WIRES	PHASE	VOLTS	SERVICE TYPE	MAX AMPS	INSTALLATION TYPE	ITEM NO.	MANUFACTURER*	PART NUMBER*		
3	3Δ	480	Secondary Service	0-200	Mini Transocket OH or UG	312125	Milbank Durham	S3228-DL 1004941B	One: 3"	Source: One # 6-250 Load: One # 6 -250 Size: 13" X 24" X 9"
3	3Δ	480	Secondary Service	200-600	Med Transocket OH or UG	301419	Milbank Durham	S3184-XT 1004786C	Two 4"	Source: Two # 2 - 600 Load: Two # 2 - 600 Size: 18" X 30" X 12"
4	3Δ	120/240	Residential Or Secondary Service	0-200	Self-Contained OH or UG	301394	Cutler-Hammer Durham Talon/Landis & Gyr Midwest Electric Milbank Talon/Siemens Square D	UT-E7213T-HL-CH UT-H7213T-HL 40407-025 UT-H7213T-HL-MEP U9701-RXL 40407-025F UT-H7213T-HL-SQD	One 4"	Source: One # 6 - 350 Load: One # 6 - 350 Size: 13" X 19" X 5" Note: Equipped With Lever Bypass
4	3Δ	120/240	Residential Or Secondary Service	200-320	Self-Contained OH or UG	312883	Cutler-Hammer Durham Talon/Landis & Gyr Midwest Electric Talon/Siemens Square D	UT-H7306-9T-HL-CH UT-H7306-9T-HL 47707-02FL UT-H7306-9T-HL-MEP S47707-02FL UT-H7306-9T-HL-SQD	One 4"	Source: One # 2 - 600 Load: One # 2 - 600 Size: 15" X 35" X 5" Note: Equipped With Lever Bypass
4	3Δ	120/240	Residential Or Secondary Service	200-320	Self-Contained OH or UG	397389	Cutler-Hammer Durham Talon/Landis & Gyr Midwest Electric Milbank Talon/Siemens Square D	UT-H7336-9T-HL-CH UT-H7336-9T-HL 44707-02FL UT-H7336-9T-HL-MEP U4013-X S44707-02FL UT-H7336-9T-HL-SQD	One 4"	Source: One # 2 - 600 Load: Two # 2 - 350 Size: 20" X 40" X 7" Note: Equipped With Lever Bypass
4	3Δ	120/240	Residential Or Secondary Service	320-600	Med Transocket OH or UG	301418	Milbank Durham	S2674-XT 1004785A	Two 4"	Source: Two # 2 - 600 Load: Two # 2 - 600 Size: 18" X 30" X 12"
4	3Δ	120/240	Residential or Secondary Service	600-1600	Maxi- Transocket OH or UG	901728	Durham	1011714	Six 4"	Source: Six #2-600 Load: Six #2-600 Size: 33" X 42" X15"
4	3Y	120/208	Residential Or Secondary Service	0-200	Self-Contained OH or UG	301394	Cutler-Hammer Durham Talon/Landis & Gyr Midwest Electric Milbank Talon/Siemens Square D	UT-E7213T-HL-CH UT-H7213T-HL 40407-02FL UT-H7213T-HL-MEP U9701-X S40407-02FL UT-H7213T-HL-SQD	One 4"	Source: One # 6 - 350 Load: One # 6 - 350 Size: 13" X 19" X 5" Note: Equipped With Lever Bypass

* Manufacturer name and part number subject to change

** Actual dimensions will vary

METER AND SOCKET APPLICATION GUIDE (cont'd)

TABLE 5-C

APPLICATION					METER SOCKET				MAX HUB SIZE	MAX # CONDUCTORS MIN/MAX CONDUCTORS SIZES, TYPICAL DIMENSIONS **
WIRES	PHASE	VOLTS	SERVICE TYPE	MAX AMPS	INSTALLATION TYPE	ITEM NO.	MANUFACTURER*	PART NUMBER*		
4	3Y	120/208	Residential Or Secondary Service	200-320	Self-Contained OH or UG	312883	Cutler-Hammer Durham Talon/Landis & Gyr Midwest Electric Talon/Siemens Square D	UT-H7306-9T-HL-CH UT-H7306-9T-HL-447707-02FL UT-H7306-9T-HL-MEP S47707-02FL UT-H7306-9T-HL-SQD	One 4"	Source: One # 2 – 600 Load: One # 2 – 600 Size: 15" X 35" X 5" Note: Equipped With Lever Bypass
4	3Y	120/208	Residential Or Secondary Service	200-320	Self-Contained OH or UG	397389	Cutler-Hammer Durham Talon/Landis & Gyr Midwest Electric Milbank Talon/Siemens Square D	UT-H7336-9T-HL-CH UT-H7336-9T-HL-447707-02FL UT-H7336-9T-HL-MEP U4013-X S44707-02FL UT-H7336-9T-HL-SQD	One 4"	Source: One # 2 – 600 Load: Two # 2 - 350 Size: 20" X 40" X 7" Note: Equipped With Lever Bypass
4	3Y	120/208	Residential Or Secondary Service	320-600	Med Transocket OH or UG	301418	Milbank Durham	S2674-XT 1004785A	Two 4"	Source: Two # 2 - 600 Load: Two # 2 - 600 Size: 18" X 30" X 12"
4	3Y	120/208	Residential or Secondary Service	600-1600	Maxi - Transocket OH or UG	901728	Durham	1011714	Six 4"	Source: Six #2-600 Load: Six #2 - 600 Size: 33" X 42" X 15"
4	3Y	277/480	Residential or Secondary Service	0-200	Mini - Transocket OH or UG	901553	Durham	1011607	One 3"	Source: One #6-250 Load: One #6 - 250 Size: 13" X 30.5" X 9.75"
4	3Y	277/480	Residential or Secondary Service	200-600	Med- Transocket OH or UG	901552	Durham	1011606	Two 4"	Source: Two #2-600 Load: Two #2 - 600 Size: 18" X 35" X 12.56"
4	3Y	277/480	Residential Or Secondary Service	600-1600	Maxi- Transocket OH or UG	901554	Durham	1011630	Six 4"	Source: Six #2-600 Load: Six #2 - 600 Size: 33" X 42" X 15"
4	3Y	120/208 or 277/480	Secondary Service	1601-4000	Mega-Transocket UG only	911761	Durham	1011676	N/A	Source Eight 1/0 - 750 Load: Sixteen 1/0 - 750 (Lay-in Connector) Size: 60Hx48W24D
ANY APPLICATION				>1600 (excluding Mega)	CONSULT COMPANY FOR SERVICE ENCLOSURE AND/OR INSTRUMENT TRANSFORMER ENCLOSURE OPTIONS					

* Manufacturer name and part number subject to change

** Actual dimensions will vary

TRANSOCKET CONFIGURATIONS AND CONNECTION DETAILS

FIGURE 5-D

GENERAL INFORMATION

The basic wiring configurations for transockets are shown in the following figures. Transockets are available in four ampacity ranges:

- a. Up to 200 amps - "MINI", with "Lay in" type connectors and Wall Mounted
- b. 201- 600 amps - "MEDIUM", with Double barrel, set-screw type connectors and Wall Mounted
- c. 601-1600 amps - "MAXI", with Double barrel, set-screw type connectors Wall Mounted or Pad Mounted
- d. 1601-4000 amps - "MEGA", NEMA connections

Note: See Table 5-C, pages 56-61 for connector specifications, the TSN, and other selection data.



APPLICATION - MINI (200 Amp Max)

Nominal Size: 13x24x9 - 480 V, 3-wire, 3 ϕ Delta only For Ungrounded Service See 100.05.03, page 12 and 500.06.07, page 43.
TSN **312125**



APPLICATION - MINI (200 amp max)

Nominal Size: 13x24x9
480 V, 2-Wire, 1 ϕ
240/480 V, 3-Wire, 1 ϕ
TSN **320797**

TRANSOCKET CONFIGURATIONS AND CONNECTION DETAILS (cont'd)
FIGURE 5-D

APPLICATION - MINI (200 Amp Max.)
 Nominal Size: 13x31x10
 277/480 V, 4-Wire, 3Ø Wye Only
TSN 901553



APPLICATION - MEDIUM (201-600 Amps)
 Nominal Size: 18x30x12
 120/240 V, 3-Wire, 1Ø
 240 V, 3-Wire, Delta
TSN 301417



APPLICATION - MEDIUM (201-600 Amps)
 Nominal Size: 18x30x12
 120/208 V, 4-Wire, 3Ø Wye
 120/240 V, 4-Wire, 3Ø Delta

“Power Leg” of 4-wire delta shall connect to right-hand CT and be identified by an outer finish that is orange in color.

TSN 301418



APPLICATION - MEDIUM (201-600 Amps)
 Nominal Size: 18x30x12
 480 V, 3-Wire, 3Ø Delta
TSN 301419

TRANSOCKET CONFIGURATIONS AND CONNECTION DETAILS (cont'd)

FIGURE 5-D

APPLICATION - MAXI (600 - 1600 Amp Max)
 Nominal Size: 33x42x15
 277/480 V, 4-Wire, 3 ϕ Wye
TSN 901554



APPLICATION - MAXI (600 - 1600 Amp Max)
 Nominal Size: 30x42x14
 120/240 V, 3-Wire, 1 ϕ
 120/240 V, 3-Wire, 3 ϕ Delta
TSN 302775



APPLICATION - MAXI (600 - 1600 Amp Max)
 Nominal Size: 33x42x15
 120/208 V, 4-Wire, 3 ϕ Wye
 120/240 V, 4-Wire, 3 ϕ Delta
 "Power Leg" of 4-wire delta shall connect to
 right-hand CT and be identified by an outer
 finish that is orange in color.
TSN 901728

APPLICATION - MEGA (1601-4000 Amp Max)
 Nominal Size: 48x60x24
 277/480 V, 4-Wire, 3 ϕ
 120/208 V, 4-Wire, 3 ϕ
 (Pad Mount Only)
TSN 911761

TRANSOCKET CONFIGURATIONS AND CONNECTION DETAILS (cont'd)

FIGURE 5-D

Permissible Entrance and Exit Locations for Transocket Conductors

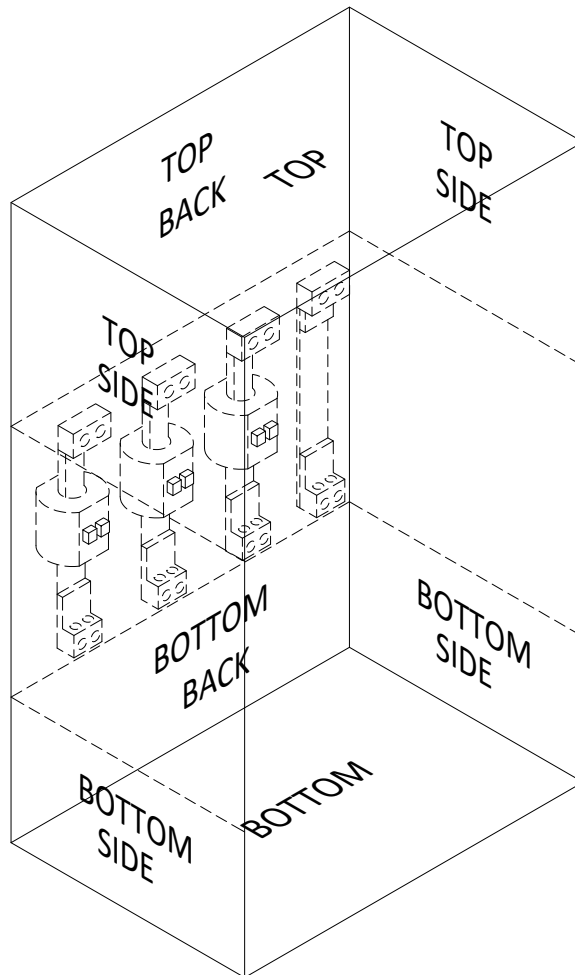

Integrity of Connections – When installing conductors in transockets, it is the responsibility of the installer to ensure that all line and load connections are tight, including the connections between the CT bus bar and the connector.

Transocket - Overhead Service

1. For overhead installations, line conductors must enter the transocket top, top back, or top sides and connect to transocket top terminals.
2. Load conductors must connect to the transocket bottom terminals and exit through the transocket bottom, bottom back, or bottom sides.

Transocket - Underground Service

1. For underground installations, line conductors must enter through the transocket bottom, bottom back, or bottom sides and connect to the transocket bottom terminals.
2. Load conductors must connect to the transocket top terminals and exit through the top, top back, or top sides.
3. Reserve adequate space beneath the transocket for service raceway.
4. If source conductors to transocket is directly from a Secondary Pedestal, the conductor size shall be limited to 500 kcmil.

TYPICAL SERVICE ENCLOSURE

FIGURE 5-E



AMPACITY	APPLICATION	BUS ARRANGEMENT	HUB OPENINGS FOUR INCH MAX (Order hubs separately)	TYPICAL WxHxD (Inches)	COMPANY ITEM NUMBER (TSN)
600	Three wire, One-phase	Accommodates two #4-600 kcmil (Line) and 250-350 kcmil (Load) conductors per phase. (Set Screw Connection Only)	One	16x24x6	312726
1100	Three wire, One-phase Wall mount	Standard with three horizontal connection bus bars, each with eight #10-350 kcmil integrated set screw connectors per bus. Add the extra connector bar (TSN 320781) to convert to four wire, three phase. (Set Screw Connection Only)	Two	12x50x8	312723
1200 (Note: 1 and 2)	Four wire, Three-phase Wall mount	Three vertical connector bus bar (Phase) and one horizontal bus. (Neut). Each with Twenty Four #10-350 kcmil integrated set screw connectors per bus. Each bus also has Eleven Sets of Two-Hole NEMA spaced holes per bar.	Four	30x42x14	310935
2500 (Note 1 and 2)	Four wire, Three-phase Pad Mount	Four horizontal tin-plated aluminum bus bars, Each with thirty #10-350 kcmil integrated set screw connectors per bus. Each bus also has Eighteen Sets of Two-Hole NEMA spaced holes per bar. (UG Service Only)	Six	44x54x24	300313

Notes:

1. Source conductors must connect in the center of bus bars for full ampacity rating.
2. The conductor sizes is #10-350 kcmil for all integrated set screw bus bars connections. The conductor size #4-600 kcmil for all Two-Hole NEMA spaced bus connections. (Two-Hole Compression Connectors Only - No Mechanical/Bolt Type Connectors will be Acceptable)
3. Company will make available standard service enclosures and no substitutions will be allowed.
4. Customer conductor cannot enter and exit the same side of the service enclosure.
5. If source conductors to Service Enclosure is directly from a Secondary Pedestal the conductor size shall be limited to 500 kcmil.

GANG METER SOCKETS MULTIFAMILY TYPICAL LAYOUTS

FIGURE 5-F

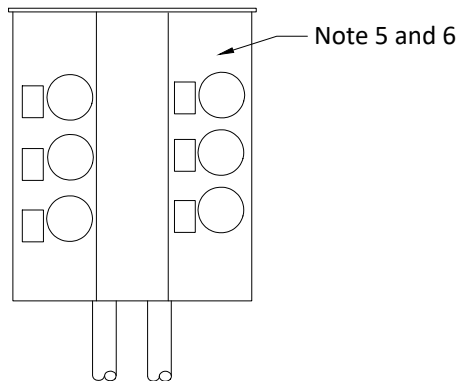
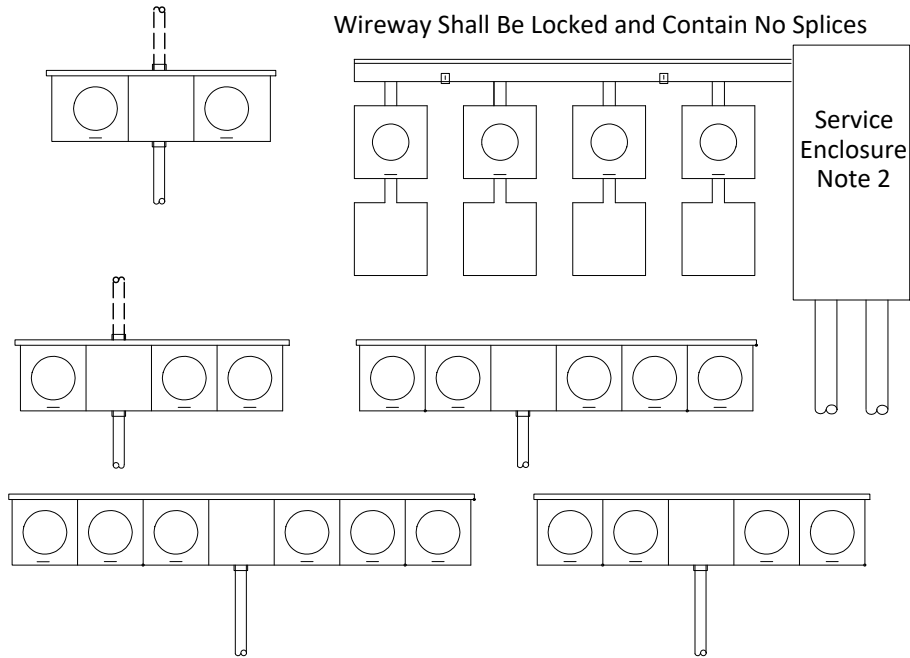

Notes:

1. Each socket must be clearly and permanently marked as indicated in Section 500.11, page 47.
2. Meter sockets shall be provided, installed and maintained by Customer. Transockets, when required, shall be provided by Company and installed by Customer. Company locks or seals will be installed at each meter socket. See Table 5-C, pages 56-61 for list of approved meter sockets. Service enclosure (when required) to be provided by Company and installed by Customer. See 500.08, page 47 for details. Company locks and or seals will be installed as needed.
3. **Contact Company for approval of layouts other than those shown above prior to installation.**
4. **Contact Company for approval of meter packs prior to letting bids and installing equipment. See 500.06.03, page 44 for details.**
5. It is the Customer's responsibility to determine local code requirements concerning meter packs with main switches or main circuit breakers prior to installing equipment.
6. Meter packs with meter stacks up to 5 will be permitted under certain conditions. Maximum mounting height is 6 feet to the center of the top meter socket. For meter stacks that have 5 vertical positions, a permanent hard surface extending a minimum 24 inch in front of the meter pack and the width of the meter pack is required. The Customer ground lug should be located in the Customers compartment so the Customer can have ready access. This may not be possible with small breakers. Contact Company representative for details.

METER SOCKET CONNECTIONS AND VOLTAGES

FIGURE 5-G

APPLICATION: TWO-WIRE, 120 V, 1 ϕ SELF-CONTAINED, FORM 1

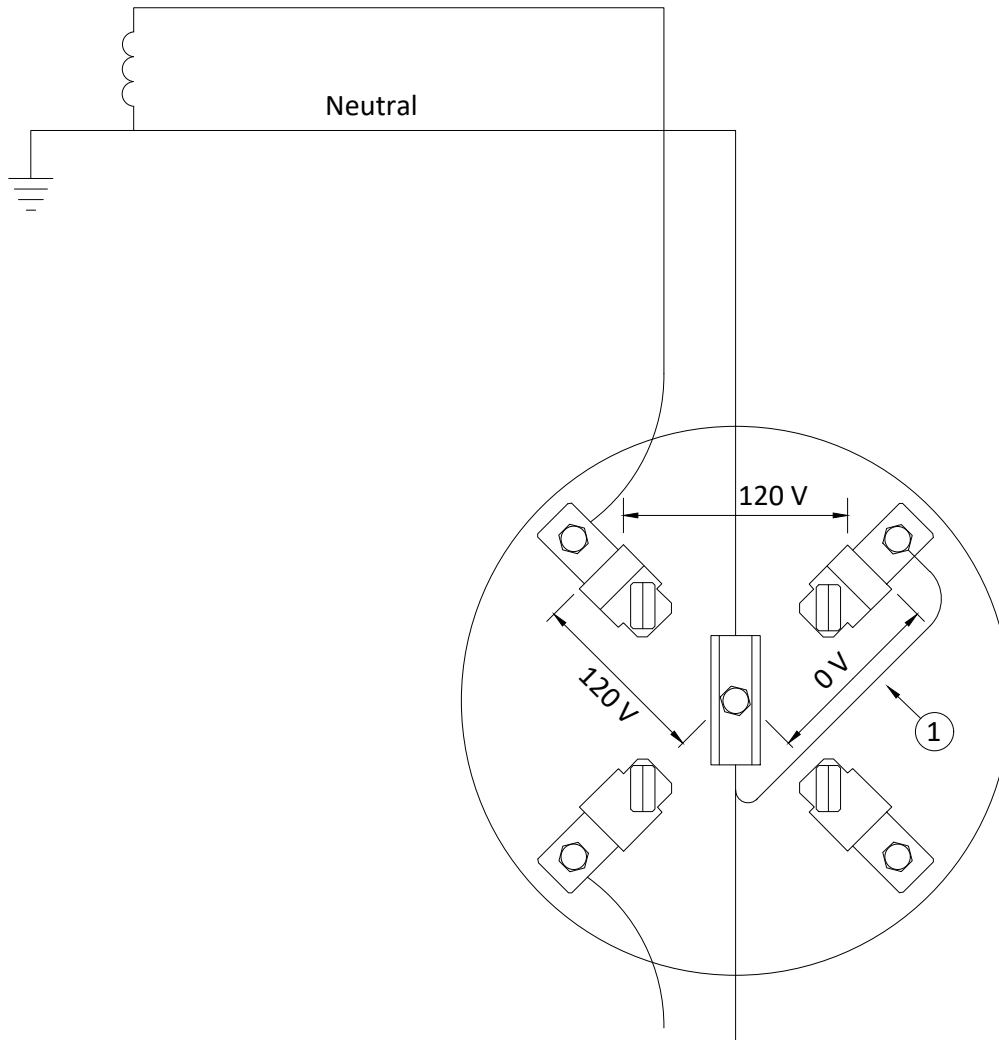

Note:

1. Jumper must be installed between neutral connector and upper right terminal.

METER SOCKET CONNECTIONS AND VOLTAGES (cont'd)

FIGURE 5-H

APPLICATION: THREE-WIRE, 120/240 V, 1 ϕ SELF-CONTAINED, FORM 2

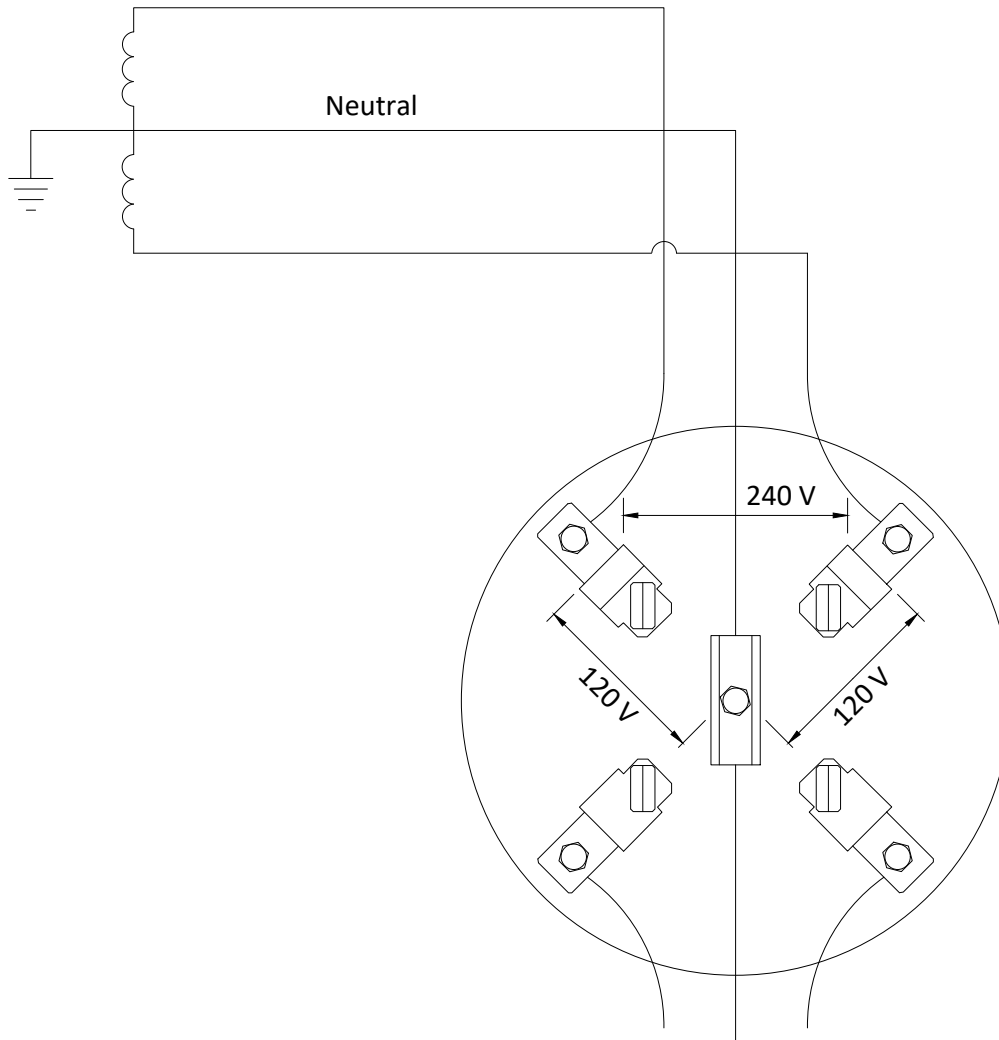

METER SOCKET CONNECTIONS AND VOLTAGES (cont'd)

FIGURE 5-1

APPLICATION: THREE-WIRE NETWORK, 120/208 V, 1 ϕ SELF-CONTAINED NON-STANDARD, FORM 12

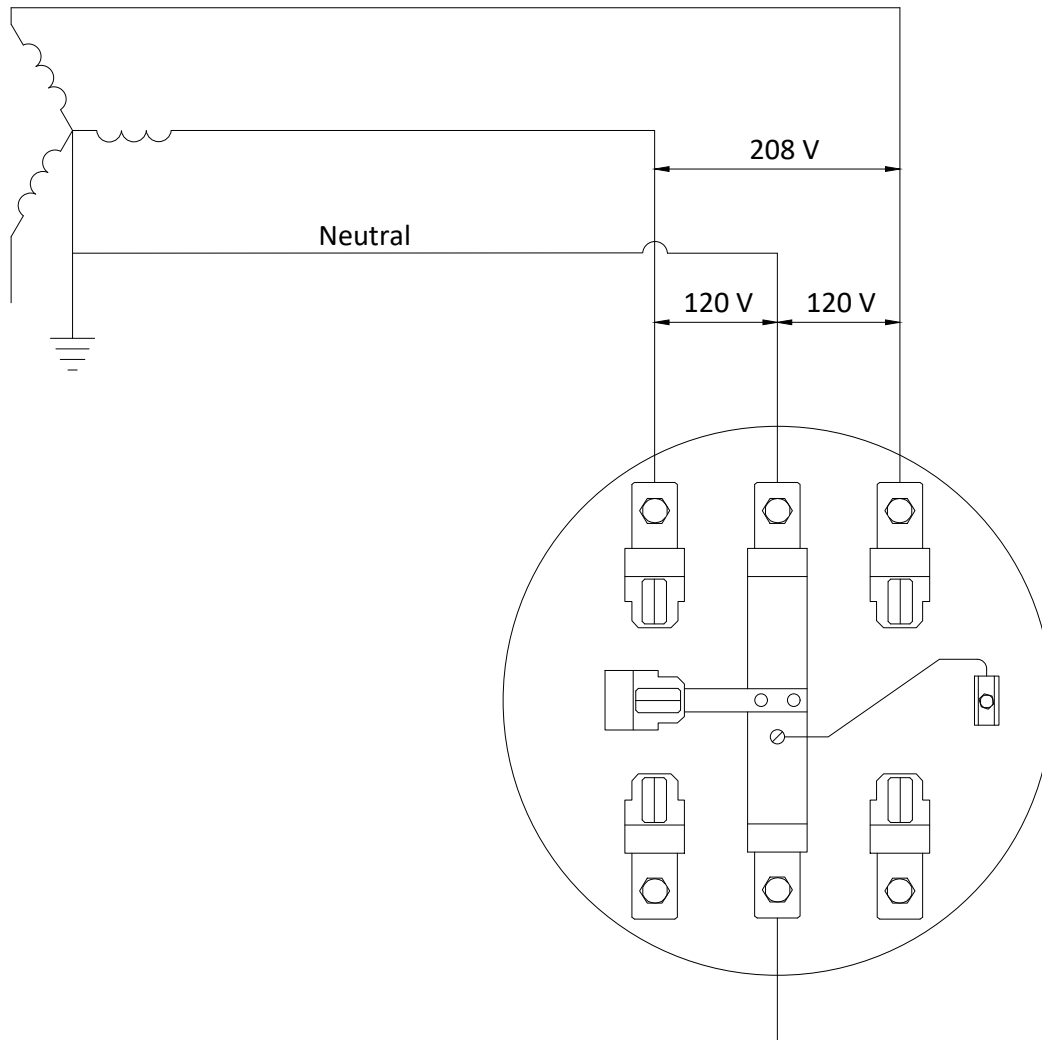

Note:

1. See 100.05.04, page 13 for application, availability and imitations. Network Secondary Service Customers not to exceed 60 amperes. Non-network Secondary Service Customers are not to exceed 200 amperes.

METER SOCKET CONNECTIONS AND VOLTAGES (cont'd)

FIGURE 5-J

APPLICATION: FOUR-WIRE, WYE 120/208 V, 3 ϕ SELF-CONTAINED, FORM 16

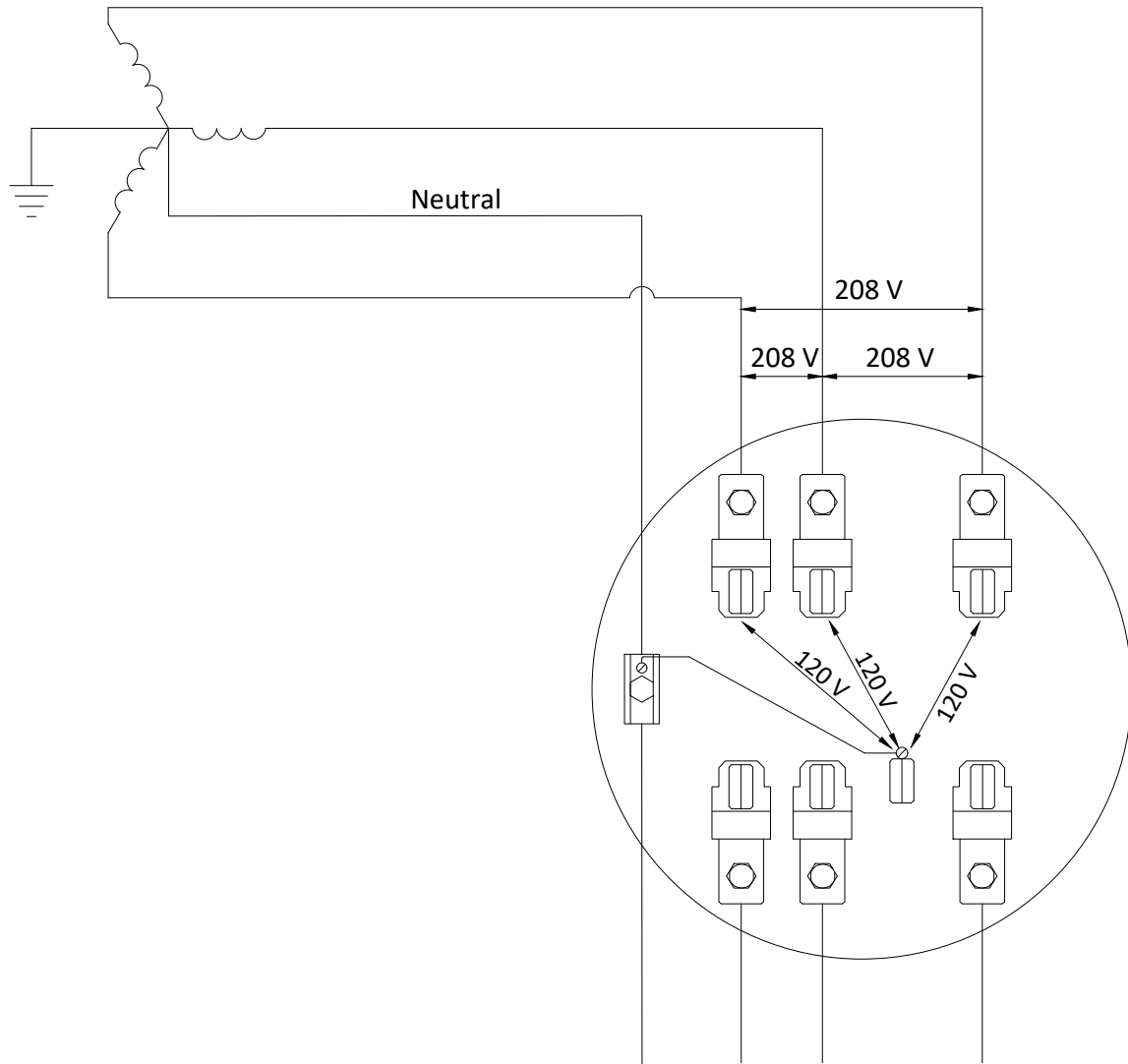

METER SOCKET CONNECTIONS AND VOLTAGES (cont'd)

FIGURE 5-K

APPLICATION: FOUR-WIRE, DELTA 120/208/240 V, 3 ϕ SELF-CONTAINED, FORM 16

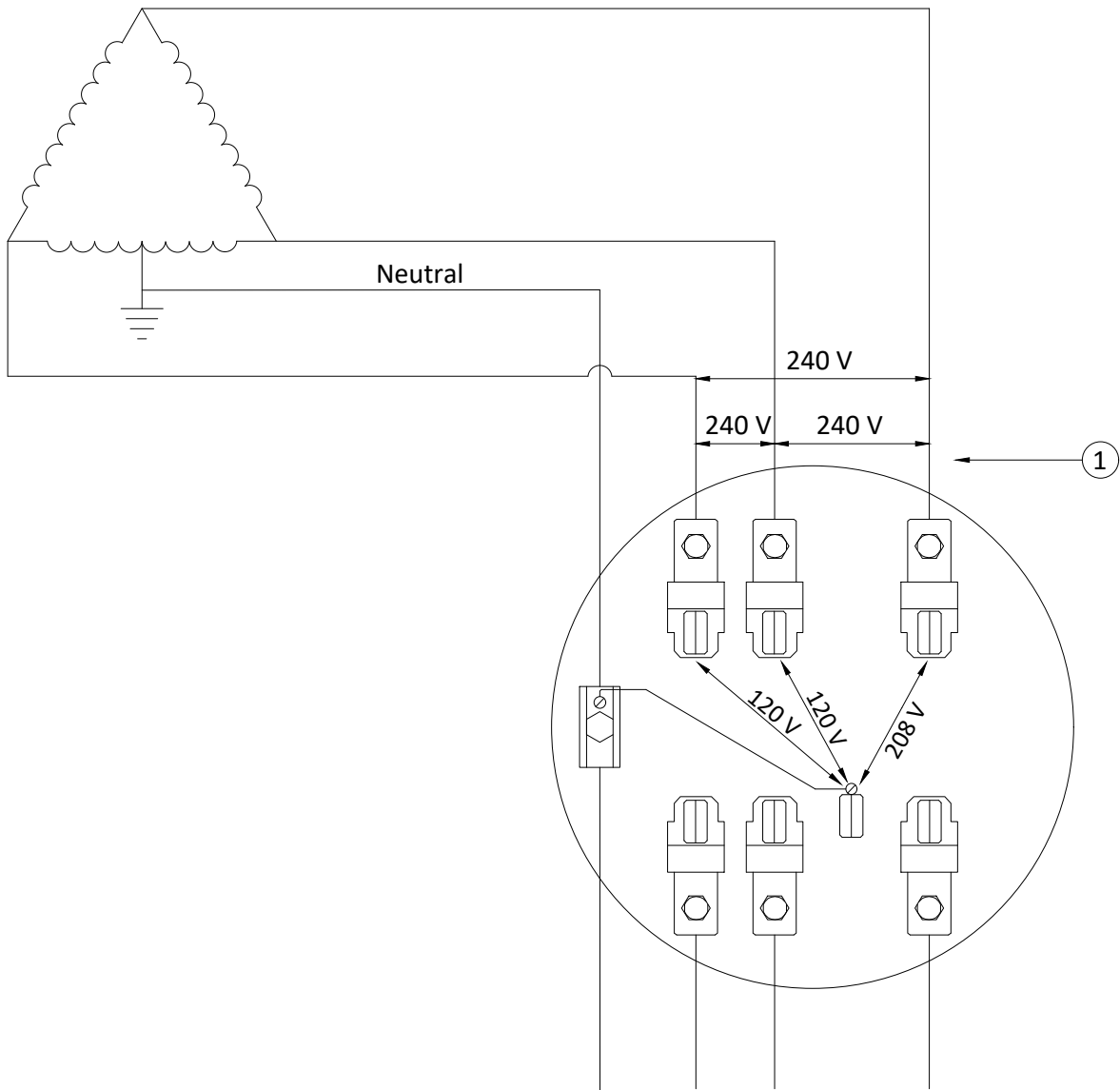

Note:

1. On a four-wire delta connection, the phase having the highest voltage to ground (Power leg, high leg, wild leg, or freak leg) must be connected to right-hand terminals of the meter socket. In other locations such as service enclosures, disconnects, etc., the "Power Leg" is connected to the center terminal.

SECTION 600

TEMPORARY SERVICE INSTALLATION

600.01 General

To initiate temporary service for construction or other purposes, contact Oncor at 1.888.222.8045. Customer must choose a Retail Electric Provider in order to have a meter installed for temporary service to be delivered (energized).

To view a list of approved Retail Electric Provider's in Texas, Customers may research information posted at: www.powertochoose.com

600.02 Temporary Service from Overhead Secondary

See Figure 6-A, page 74.

600.03 Temporary Service from Underground Secondary

See Figure 6-B, page 75.

TEMPORARY SERVICE POLE FROM OVERHEAD SECONDARY

FIGURE 6-A

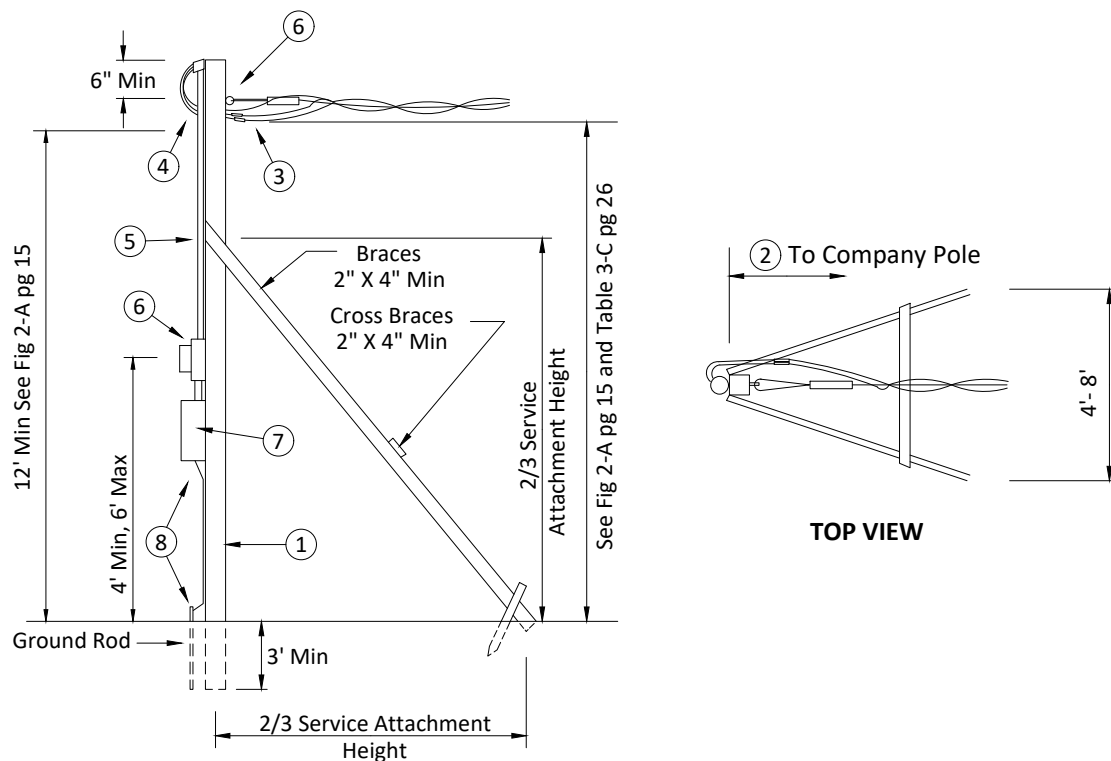

Notes:

1. Temporary service pole provided and installed by Customer. Pole must provide sufficient height for the service drop to meet minimum clearances given in Figure 2-A, page 16 (12 feet minimum). Pole to be a minimum 4 inches X 4 inches X 16 feet unspliced or 5 inch minimum diameter at top of treated pole.
2. Service pole must be within maximum distance as specified on Table 3-C, page 27. Reduced distance may be required for larger services to maintain minimum clearances.
3. Service drop conductors, service grips and service connectors owned and installed by Company.
4. Service entrance conductors (#8 Copper or #6 Aluminum minimum), provided and installed by Customer, shall extend 24 inches or the minimum length required by local ordinance outside of the service head for connection to Company service drop. Phase conductors to have black insulation and neutral conductor to be marked white or bare.
5. Service head and raceway provided and installed by Customer to protect service entrance conductors. Two or more conduit straps shall be provided to support conduit.
6. Service attachment and meter socket provided, installed and maintained by Customer. Customer installs service drop attachment of adequate strength for attachment of Company's service drop conductors. See Figure 3-B, page 26.
7. Weatherproof service switch or breaker panel provided and installed by Customer.
8. Customer's ground rod conductor (#6 Copper minimum) shall originate in the service entrance equipment and extend to a ground rod . The ground rod conductor shall not terminate within the meter socket. Company reserves the right to refuse installation of service contingent upon observing an unsafe Customer connection.
9. All other materials provided and installed by the Customer.
10. Customer shall not allow pole to be moved or tampered with as long as Company's service conductors are attached.
11. Temporary pole shall be marked to identify premise and address with a minimum of 3 inch numbers.

TEMPORARY SERVICE POLE FROM UNDERGROUND SECONDARY

FIGURE 6-B

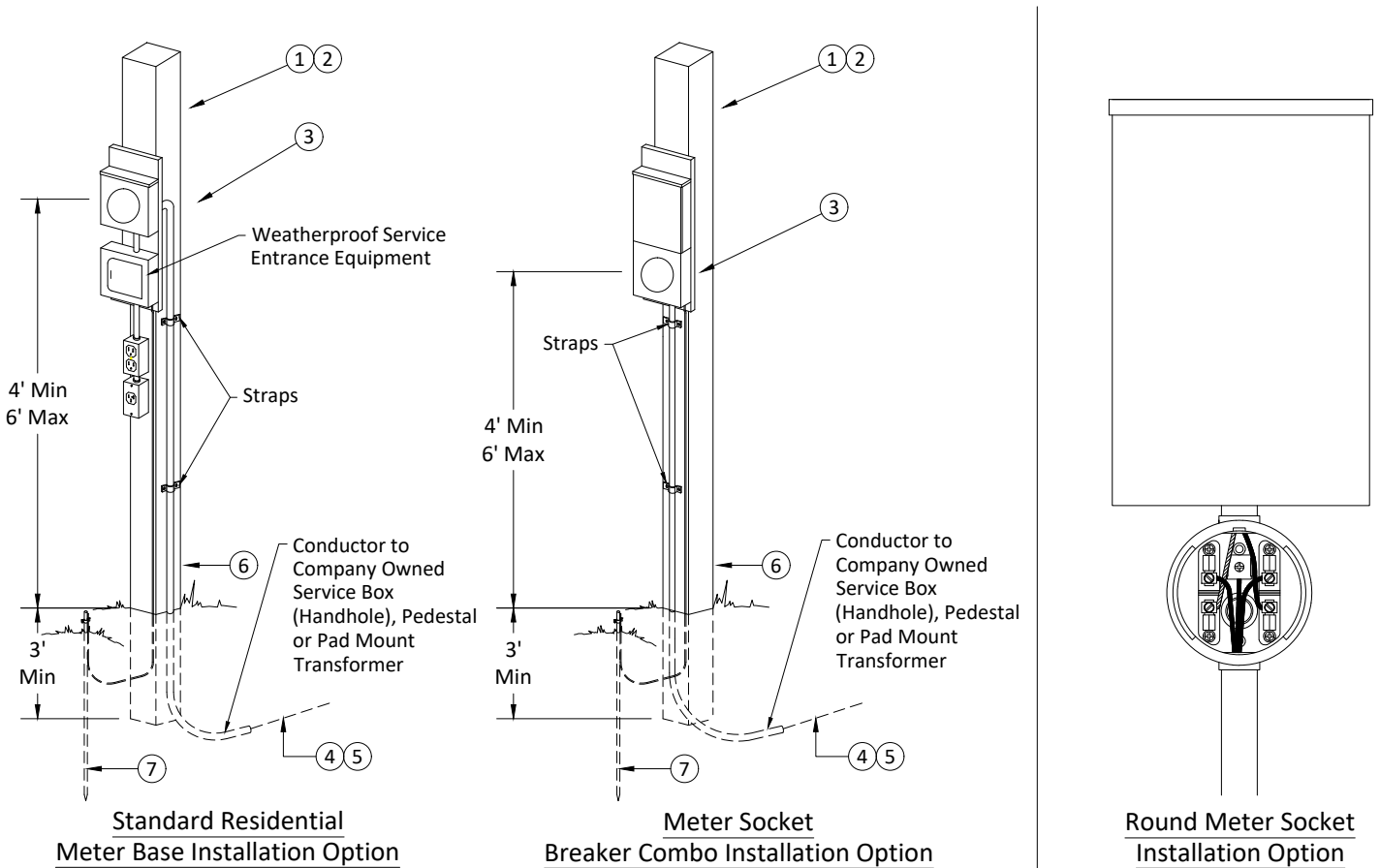

Notes:

1. Service support to be 4 inches X 4 inches minimum wood pole, unspliced and set a minimum 3 feet deep. Pole should be installed 6 feet from any alley, sidewalk, or drive.
2. Customer shall not allow pole to be moved or tampered with as long as Company's service conductors are attached.
3. Service entrance equipment and pole will be provided, installed, and maintained by the Customer. Customer shall provide, install, and maintain meter socket. Refer to Table 5-C, pages 58-61 for approved meter socket options, 500.06.04, page 44 for line-side connection information. Contact Company Representative with questions. Customer must mark meter socket with correct 911 address.
4. Conduit and wire will be furnished by Customer from line-side meter terminals to the point of connections at the transformer pad, pedestal, or handhole. The line and load side conductors contained inside the meter base shall not cross. Customer will trench within 2 feet of right front side of transformer pad or within 2 feet of pedestal or handhole. Company will make final trenching and connections.
5. Customer furnished wiring from line-side terminals of meter socket to connections at pad transformer, pedestal or handhole may be direct buried where installed with 2 feet minimum of earth cover.
6. Where exposed above ground, conductors shall be installed in rigid metallic or flexible metallic conduit.
7. Customer's ground rod conductor shall originate from service entrance equipment and shall not terminate in the meter socket. Customer's ground rod conductor shall originate from service entrance equipment and shall not terminate in the meter socket. Customer's ground rod conductor shall be #6 Copper minimum and connected to a ground rod (pole butt-wrap is not an approved ground electrode). Company reserves the right to refuse installation of service contingent upon observing an unsafe Customer connection.
8. Temporary pole shall be marked to identify premise and address with a minimum of 3 inch numbers.

SECTION 700

SOLAR, BATTERY STORAGE, AND OTHER ON-SITE DISTRIBUTED GENERATION (DG)

700.01 General

This section should be used as a guide in planning the installation and Parallel Operation of Customer-owned On-Site Distributed Generation such as rooftop solar and battery storage. The information in this section will help to ensure the safe and reliable operation of Distributed Generation Facilities and does not take precedence over any applicable electrical codes or requirements.

700.02 Interconnection Agreement

All Distributed Generation connected for Parallel Operation with the Company grid must work through the interconnection process with the Company to obtain an Interconnection Agreement before the system is energized. For information on solar, battery storage, and other forms of customer-owned On-Site Distributed Generation (DG) please contact Oncor at dg@oncor.com or visit the following websites: www.oncor.com/solar or www.oncor.com/dg.

Installers may visit <https://oncor.anbetrack.com/dgportal> to register, submit and track the status of new Distributed Generation projects through the eTRACK web portal.

700.03 Visible Lockable Labeled AC Disconnect

A Visible Lockable Labeled AC Disconnect (VLLD) must be located between the Company Meter and all sources of Distributed Generation. The VLLD must have an external handle and be lockable. Molded-case breakers are not considered to be an acceptable VLLD.

The VLLD must be located on an accessible exterior wall within 10 feet of the Company Meter as shown in Figure 1. If the VLLD is not located within 10 feet of the Oncor Meter, specialized placarding will be required (see section 700.04 - Company Placard Guidelines). The VLLD must be accessible at all times.

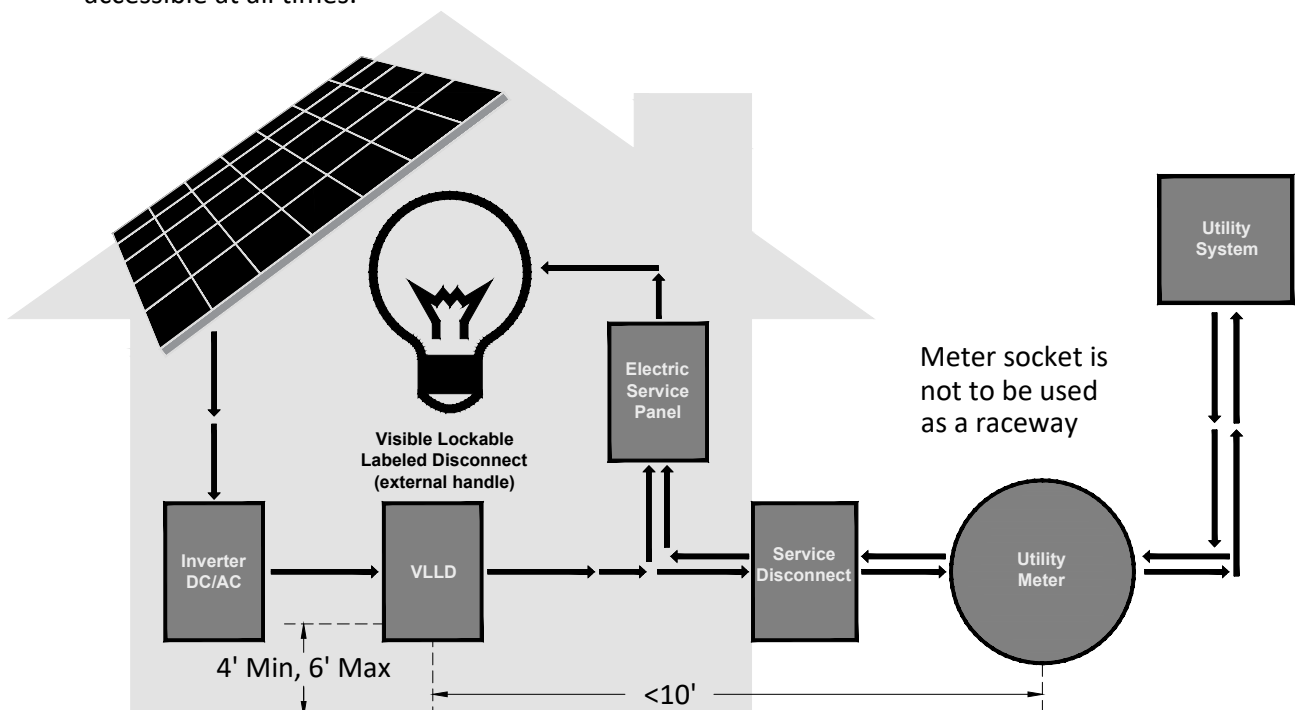

FIGURE 1

SOLAR, BATTERY STORAGE, AND OTHER ON-SITE DISTRIBUTED GENERATION (DG) (cont'd)

700.04 Company Placard Guidelines for Distributed Generation

Company requires caution or warning placards on all distributed generation projects to alert company employees of a potential alternate source of power. Company interconnection requirements specify a manual disconnect device that is visible and located on an exterior wall and close to the Company Meter (see section 700.03 - Visible Lockable Labeled AC Disconnect). Placards are required to be located on the visible AC disconnect and not on the Company Meter. Company requires that proof of placards be submitted for review. Company placard specifications are not intended to take precedence over any applicable electrical codes or requirements.

700.04.01 Placard Materials

Customers may use color cast acrylic placards or placards on sticker type material only if material is outdoor-rated and of similar specification to the requirements in the National Electric Code (NEC). Both must have an UV inhibitor rated for exterior use.

700.04.02 Distance Determined Placard Class

Based on the distance of the VLLD to the Company Meter, different classes of placarding may be required. The class sections below outline the different requirements of each class of placarding.

700.04.03 Class 1 - VLLD is located within 10 feet of the Company Meter

Class 1 placarding is used when the VLLD is located within 10 feet of Company meter. Below is an example of sample language for a Class 1 placard.



FIGURE 2 - CLASS 1 PLACARD

SOLAR, BATTERY STORAGE, AND OTHER ON-SITE DISTRIBUTED GENERATION (DG) (cont'd)

700.04.04 Class 2 - VLLD is located more than 10 feet from Company Meter

Class 2 placarding is used when the VLLD is located greater than 10 feet from Company meter. Company requests the VLLD be located near the Company Meter and only under exception should it be located remotely from the Company meter. In these cases it is required that placarding describing the location of the VLLD be posted within line of sight and viewable distance of the Company Meter. Below is an example of sample language for a Class 2 placard.



FIGURE 3 - CLASS 2 PLACARD

700.04.05 Class 3 - Site Map is needed for VLLD location

Class 3 placarding is used when the facilities are fed from an Oncor pad mounted transformer or when the VLLD is installed at a remote location from the Oncor Meter. The general process for this type of installation is for two placards to be utilized. Below is an example of a site map and sample language for a Class 3 placard.



FIGURE 4 - CLASS 3 SITE MAP



FIGURE 5 - CLASS 3 PLACARD

SOLAR, BATTERY STORAGE, AND OTHER ON-SITE DISTRIBUTED GENERATION (DG) (cont'd)

700.04.06 Class 3 Site Map Details

1. The basic elements of the site map should include the following:
 - 1.1. Location of the Company meter and Company delivery equipment
 - 1.2. Location of the Customer's main AC disconnect (VLLD)
 - 1.3. Service address
 - 1.4. North indicator and basic street and building layout
 - 1.5. Map title, example: "Location of Distributed Generation System Disconnect"

700.04.07 Class 3 Location of Placards

The intent of this process is to provide a warning to the Company operations group of a potential alternate source of power and to give individuals the opportunity to clear or open any disconnects when work is being done at the Company or Customer delivery equipment. Company requires placards identical to those located on the VLLD to be installed on the Customer's main equipment to provide additional recognition. For high voltage installations, safety precautions utilizing visual opens and grounding will be implemented. Placard solutions for this class of installation are unique and alternate solutions can be proposed and coordinated with Company.

700.04.08 Class 3 Installation Requirements:

1. Proof of placards for review
2. Upon approval, three sets of the site map and caution placard are requested:
 - 2.1. One set for installation on existing Company equipment
 - 2.2. One set for installation on the Customers main equipment
 - 2.3. One set for future use should Company equipment be replaced
3. Company requires that the Customer shall furnish Company with placards and adhesive tape
4. Company will mount the placards on Company equipment
5. Company will need to approve and communicate the acceptance of the placard installation

700.04.09 Installations Utilizing Company Pad Mounted Transformers

In addition to the above requirements, Company also requires an additional placard. This placard is a caution placard with two pre-drilled holes to attach to the conductor inside Company equipment serving the Customer.

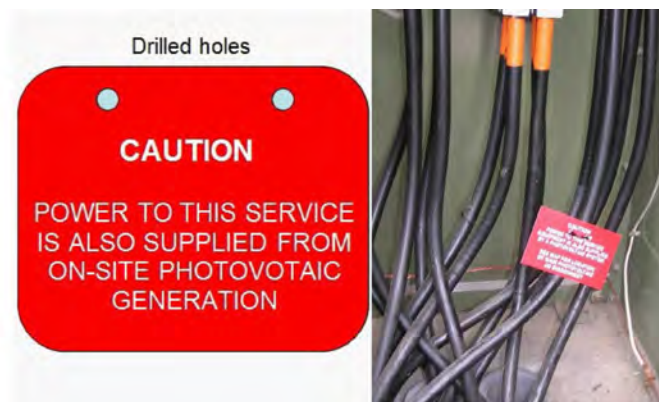

FIGURE 6 - PAD MOUNTED TRANSFORMER PLACARD

APPENDIX A

TWO HOLE COMPRESSION LUGS FOR TERMINAL CONNECTIONS

Reference: Drawings, pages 48-55 for Company-Customer Responsibility. The Customer is to furnish the connectors that meet the following specifications at pad mounted transformers and connection enclosures for connection of Customer's conductors at the point of delivery.

Mechanical/bolt type connections are not acceptable.

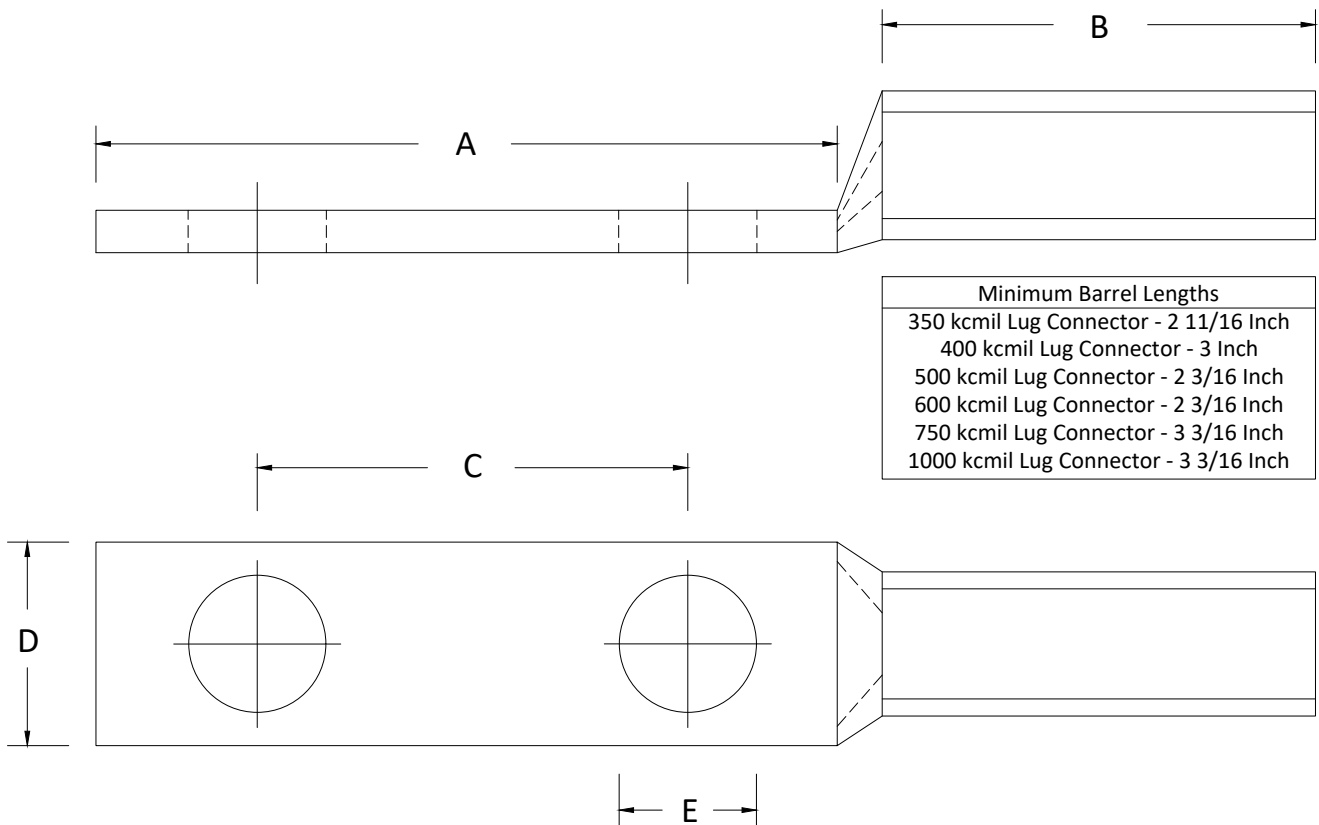

Measurements for Two-hole Compression Connectors:

- A – Sufficient for two-hole configuration
- B – Long Barrel designation per manufacturer specification
- C – NEMA two-hole spacing - 1.75 inches ONLY
- D – Maximum tongue width 1.75 inches NO EXCEPTIONS
- E – .563 inch bolt-hole inside-diameter ONLY

All Two-hole Compression Connectors must meet these specifications:

1. Manufacturer STAMPED for conductor size (cable range)
2. Manufacturer STAMPED for conductor type (Aluminum or Copper or dual rated)
3. Tin plated
4. No Inspection window
5. Two-hole NEMA spacing of 1.75 inch bolt pattern
6. Long barrel; length as per manufacturer
7. Requires use of one-half inch diameter bolts
8. DIE-INDEX stamped by manufacturer on connector
9. Factory pre-applied oxide inhibitor within each aluminum connector
10. Rated at 90°C

APPENDIX B

ONE HOLE COMPRESSION LUGS FOR TERMINAL CONNECTIONS

Reference: Drawings, pages 48-55 for Company-Customer Responsibility. The Customer is to furnish the connectors that meet the following specifications at subsurface secondary/service boxes for connection of Customer's conductors at the point of delivery.

Mechanical/bolt type connections are not acceptable.

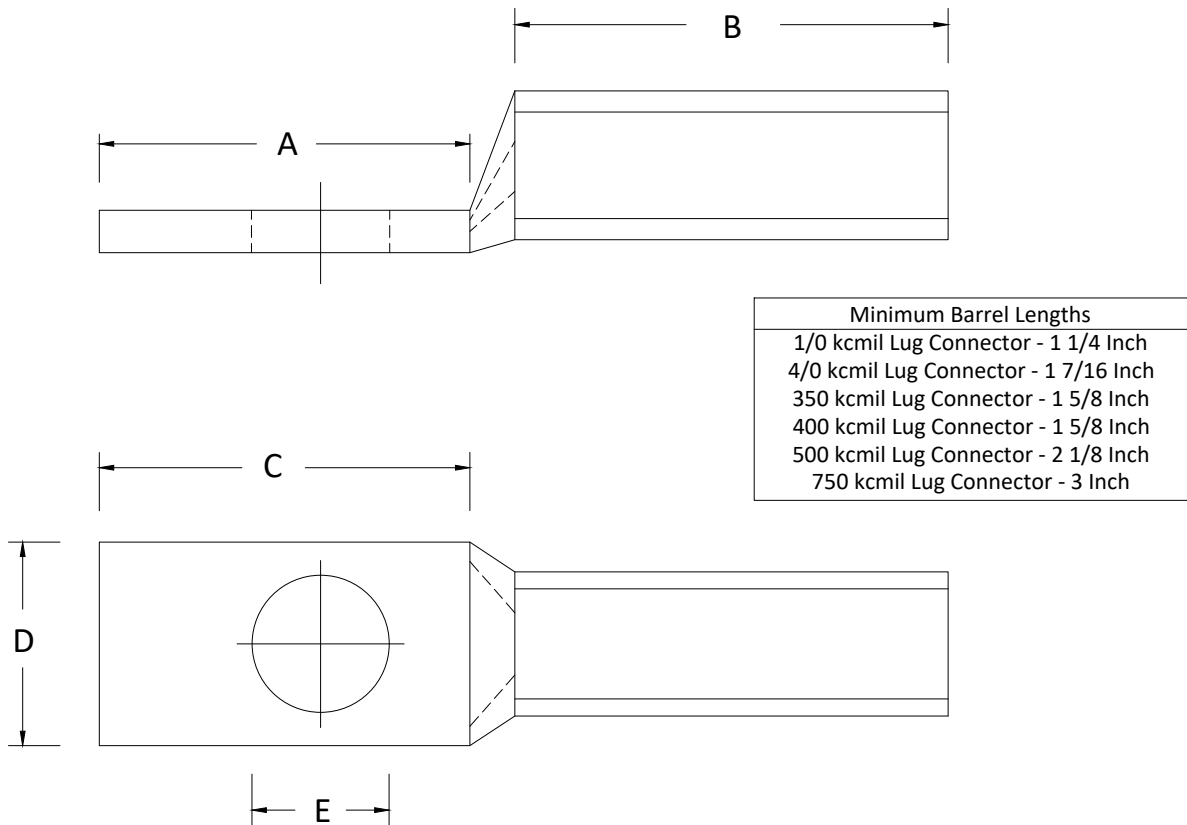

Measurements for One-hole Compression Connectors

- A – Sufficient for one-hole configuration
- B – Long Barrel designation per manufacturer specification
- C – NEMA one-hole spacing
- D – Maximum tongue width 1.75 inches NO EXCEPTIONS
- E – .563 inches bolt-hole inside-diameter ONLY

All One-hole Compression Connectors must meet these specifications:

1. Manufacturer STAMPED for conductor size (cable range)
2. Manufacturer STAMPED for conductor type (Aluminum or Copper or dual rated)
3. Tin plated
4. No Inspection window
5. Long barrel; length as per manufacturer
6. Requires use of one-half inch diameter bolts
7. DIE-INDEX stamped by manufacturer on connector
8. Factory pre-applied oxide inhibitor within each aluminum connector
9. Rated at 90°C

APPENDIX C

PRIMARY METERING EQUIPMENT CROSSARM CONSTRUCTION LOAD LESS THAN 150A

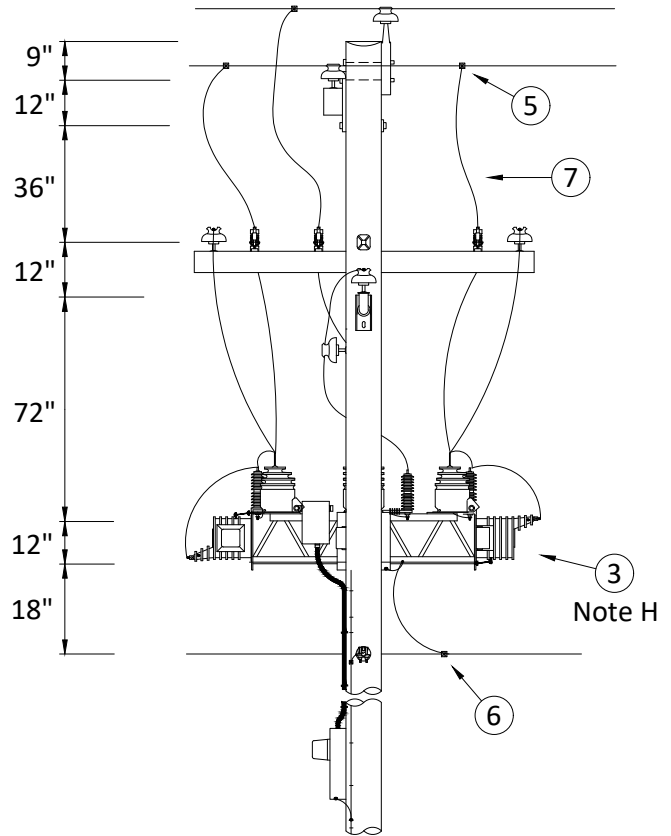
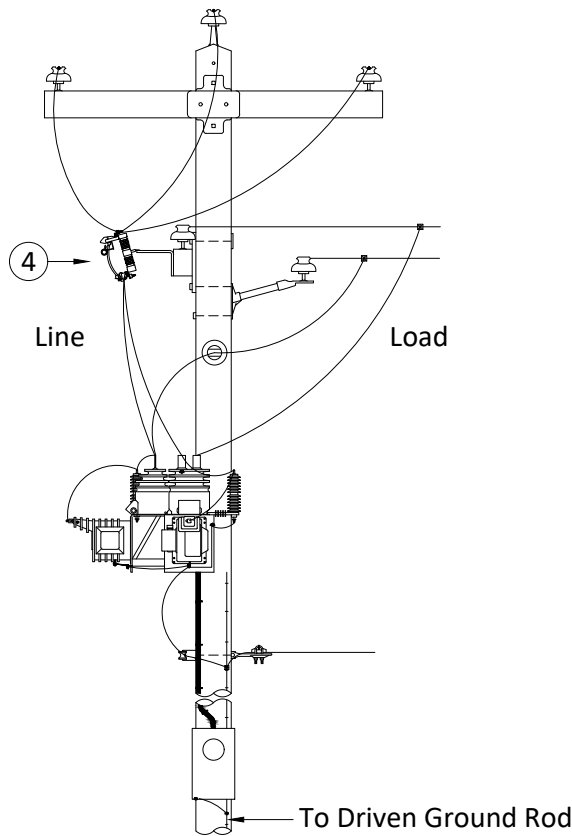

Notes:

- A. PME may be installed on separate pole between customer pole and Oncor main line pole if an easement is available.
- B. Contact Distribution Planning for fuse coordination.
- C. A recloser is required if future load growth is anticipated to exceed 150 A.
- D. Customer must properly deadend and guy their pole.
- E. Customer must match Oncor's construction framing and pole height.
- F. Customer must provide sufficient length conductor to be slacked to PME pole.
- G. Oncor will attach customer conductor to PME pole.
- H. See Section 804 of the metering handbook for PME details.
- I. Meter base shall be installed according to company guidelines and oriented such that it has safe and easy accessibility.

Item	Qty.	Description	TSN/Ref.	CU	MU
1	1	Pole, Class 3	106	PWO ____	PW ____
2	As Req.	Pole Stabilization, Foam, Polyurethane	106	BF	
3	1	Primary Metering Equipment	Note H		
4	3	Fuse Cutout	111		
5	6	Connector, Wedge, Primary	109	PWC ____	
6	9	Connector, Parallel, Groove	109	PGC ____	
7	9	Jumper, Primary		PRIJUMP __	
8	1	Driven Ground	105	GDR16365	

APPENDIX C (cont'd)

PRIMARY METERING EQUIPMENT CROSSARM CONSTRUCTION LOAD GREATER THAN 150A

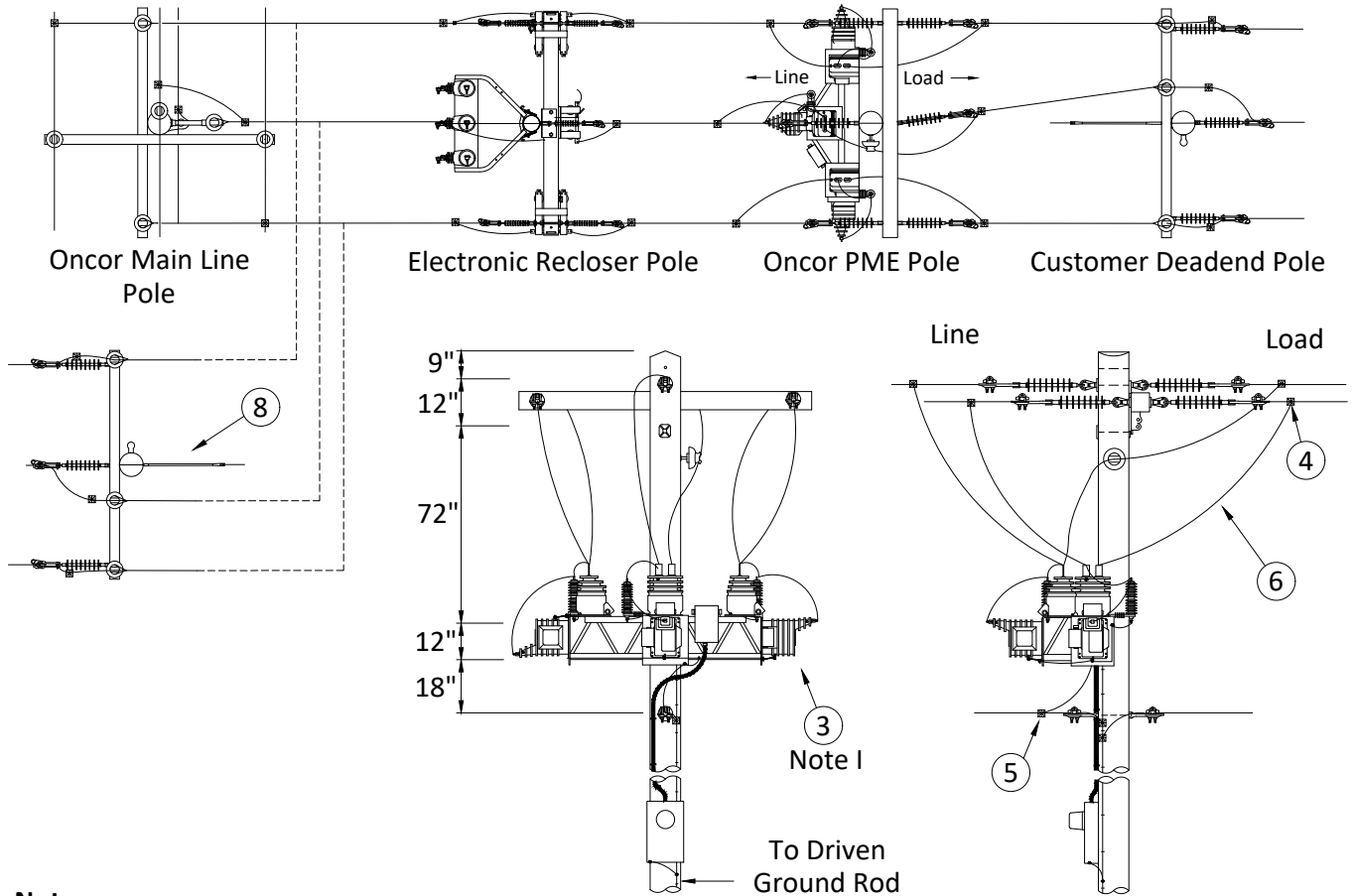

Notes:

- A. Oncor must install PME pole separate from main line via slack span.
- B. Recloser pole to be installed directly between main line and PME pole.
- C. Maximum span length between any two poles is 50 feet.
- D. Customer must properly deadend and guy their pole.
- E. Customer must match Oncor's construction framing and pole height.
- F. Customer must provide sufficient length conductor to be slacked to PME pole.
- G. Customer must provide required connectors to be attached to deadend insulators on PME pole.
- H. Oncor will attach customer conductor to PME pole.
- I. See Section 804 of the metering handbook for PME details.
- J. Meter base shall be installed according to company guidelines and oriented such that it has safe and easy accessibility.

Item	Qty.	Description	TSN/Ref.	CU	MU
1	1	Pole, class 3	106	PWO ___	PW ___
2	As Req.	Pole stabilization, foam, polyurethane	106	BF	
3	1	Primary Metering Equipment	804		
4	6	Connector, wedge, primary	109	PWC ___	
5	9	Connector, parallel, groove	109	PGC ___	
6	6	Jumper, primary		PRIJUMP __	
7	1	Driven ground	105	GDRI6365	
8	As Req.	Guy, primary	107		

APPENDIX C (cont'd)

PRIMARY METERING EQUIPMENT SHIELDED CONSTRUCTION LOAD LESS THAN 150A

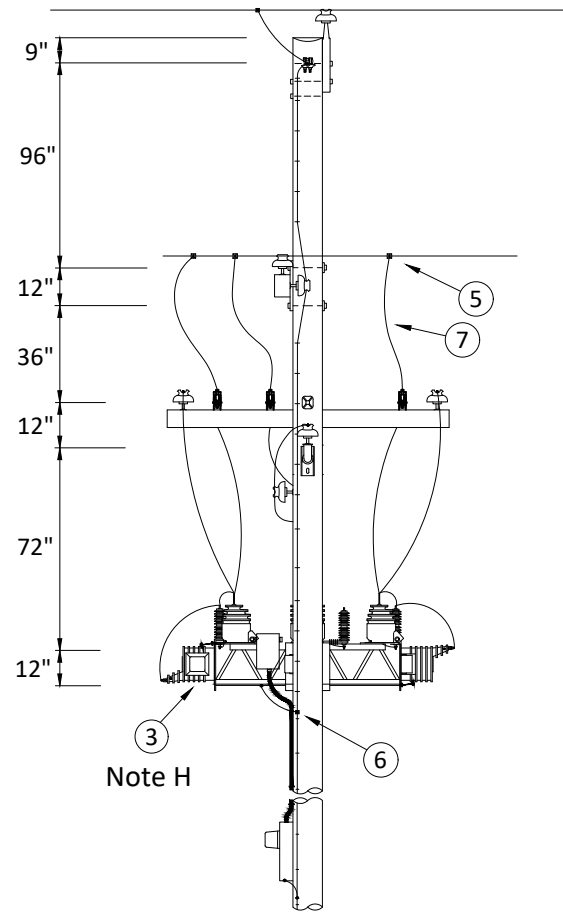
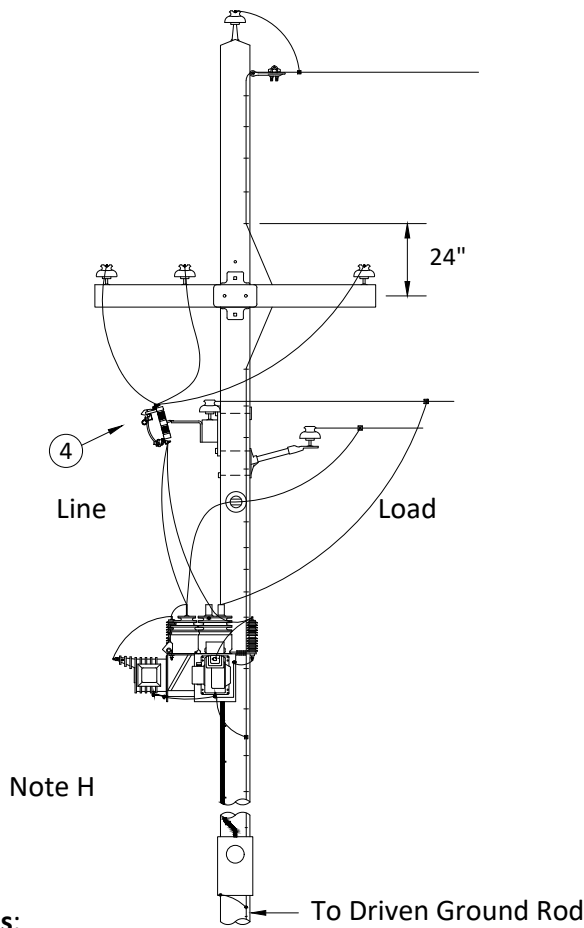

Notes:

- A. PME may be installed on separate pole between customer pole and Oncor main line pole if an easement is available.
- B. Contact Distribution Planning for fuse coordination.
- C. A recloser is required if future load growth is anticipated to exceed 150 A.
- D. Customer must properly deadend and guy their pole.
- E. Customer must match Oncor's construction framing and pole height.
- F. Customer must provide sufficient length conductor to be slacked to PME pole.
- G. Oncor will attach customer conductor to PME pole.
- H. See Section 804 of the metering handbook for PME details.
- I. Meter base shall be installed according to company guidelines and oriented such that it has safe and easy accessibility.

Item	Qty.	Description	TSN/Ref.	CU	MU
1	1	Pole, Class 3	106	PWO ___	PW ___
2	As Req.	Pole Stabilization, Foam, Polyurethane	106	BF	
3	1	Primary Metering Equipment	Note H		
4	3	Fuse Cutout	111		
5	6	Connector, Wedge, Primary	109	PWC ___	
6	9	Connector, Parallel, Groove	109	PGC ___	
7	9	Jumper, Primary		PRIJUMP __	
8	1	Driven Ground	105	GDR16365	

APPENDIX C (cont'd)

PRIMARY METERING EQUIPMENT SHIELDED CONSTRUCTION LOAD GREATER THAN 150A

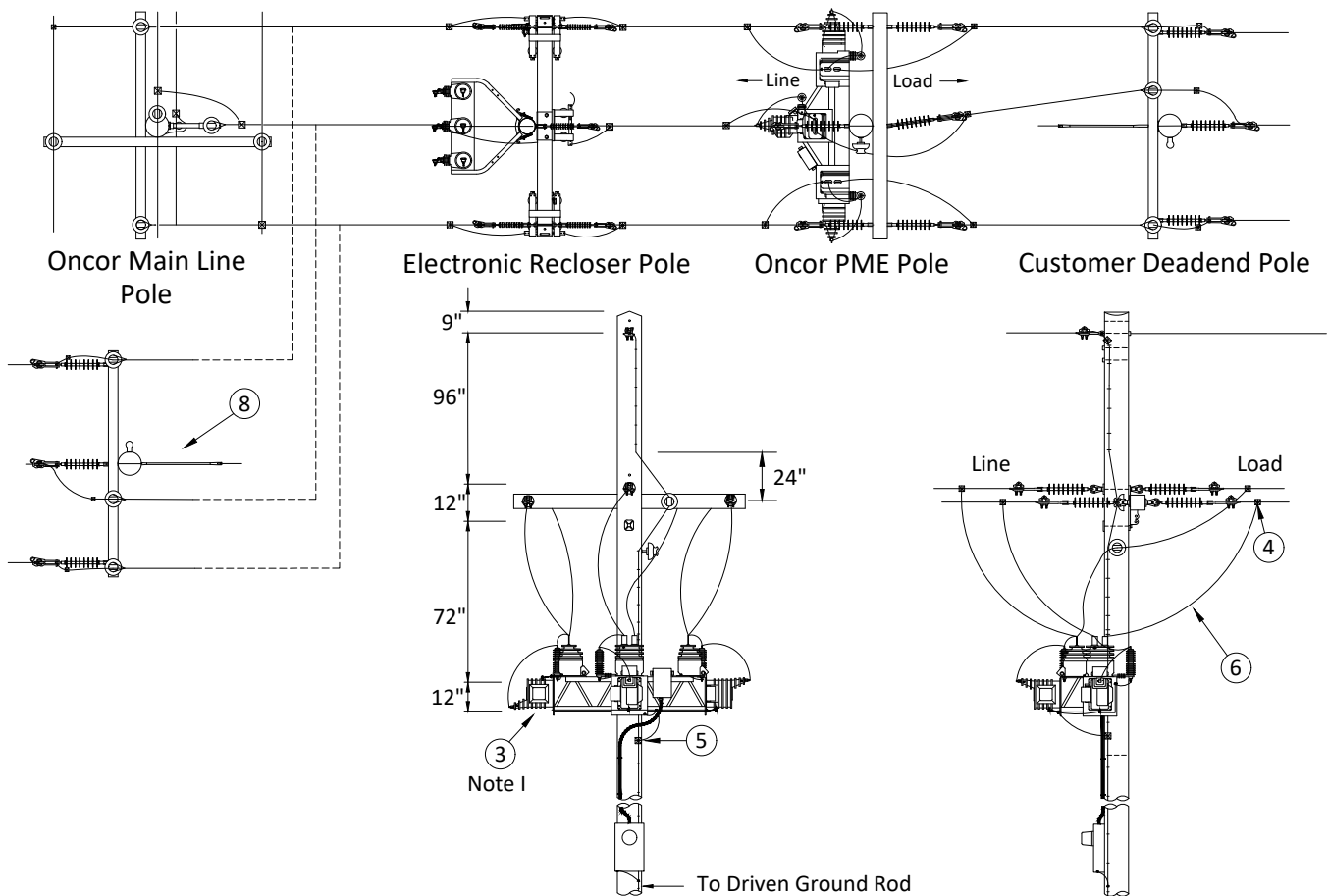

Notes:

- A. Oncor must install PME pole separate from main line via slack span.
- B. Recloser pole to be installed directly between main line and PME pole.
- C. Maximum span length between any two poles is 50 feet.
- D. Customer must properly deadend and guy their pole.
- E. Customer must match Oncor's construction framing and pole height.
- F. Customer must provide sufficient length conductor to be slacked to PME pole.
- G. Customer must provide required connectors to be attached to deadend insulators on PME pole.
- H. Oncor will attach customer conductor to PME pole.
- I. See Section 804 of the metering handbook for PME details.
- J. Meter base shall be installed according to company guidelines and oriented such that it has safe and easy accessibility.

Item	Qty.	Description	TSN/Ref.	CU	MU
1	1	Pole, Class 3	106	PWO ____	PW ____
2	As Req.	Pole Stabilization, Foam, Polyurethane	106	BF	
3	1	Primary Metering Equipment	Note I		
4	6	Connector, Wedge, Primary	109	PWC ____	
5	9	Connector, Parallel, Groove	109	PGC ____	
6	6	Jumper, Primary		PRIJUMP __	
7	1	Driven Ground	105	GDR16365	
8	As Req.	Guy, Primary	107		

SAFETY SMART. KNOW THE LAW.

Oncor wants you to be aware of the dangers of making contact with power lines. Electricity, powerful enough to kill, will flow through any metal or other conductive object and an electric arc flash can occur if a conductive object gets too close or touches electric lines. If it is possible during the course of work for someone to move to, or place any objects, within **TEN FEET*** of any high voltage overhead electric line you must first notify the operator of that electric line, at least 48 hours in advance of beginning any planned work closer to the line than those distances and arrange with the operator for permission to complete the work. For lines to be turned off, moved or other arrangements call Oncor at 1-888-313-6862.

*** WARNING - this distance should be increased for voltages above 50 kV (refer to TABLE A, below).**

Table A (ABBEVIATED)

Minimum Clearance Distances to 350 kV:

VOLTAGE (Nominal, Alternating Current)	MINIMUM CLEARANCE DISTANCE
50 kV and below	10 ft.
Over 50 kV to 200 kV	15 ft.
Over 200 kV to 350 kV	20 ft.

Some local Electrical Codes require structures to be located a safe distance away from live overhead high voltage lines, as defined by the National Electrical Safety Code (NESC).

For underground utility cable locating service - call BEFORE you Dig - toll free – 811

**BE SAFE
Around Electricity**

