



# Specifications for Electrical Underground Distribution Systems from Pad Mounted Transformation, Apartments & Condominiums

Specification DDS-3 UG  
Revision 13, November 2023

**ONCOR ELECTRIC DELIVERY COMPANY  
SPECIFICATIONS FOR ELECTRICAL UNDERGROUND DISTRIBUTION SYSTEMS  
FROM PADMOUNTED TRANSFORMATION  
APARTMENTS AND CONDOMINIUMS  
SPECIFICATION NUMBER DDS-3 UG**

**TABLE OF CONTENTS**

SECTION 1- SCOPE	Page 1
SECTION 2- REFERENCES	Page 1
SECTION 3- DEFINITIONS	Page 1
SECTION 4- GENERAL	Page 1
SECTION 5- COMPANY RESPONSIBILITY	Page 2
SECTION 6- CONTRACTOR RESPONSIBILITY	Page 3
SECTION 7- ACCEPTANCE	Page 6

ATTACHMENTS:

DDS-3 UG Detail Sheets 1 - 32

**ONCOR ELECTRIC DELIVERY COMPANY  
SPECIFICATIONS FOR ELECTRICAL UNDERGROUND DISTRIBUTION SYSTEMS  
FROM PADMOUNTED TRANSFORMATION  
APARTMENTS AND CONDOMINIUMS  
SPECIFICATION NUMBER DDS-3 UG**

**1. SCOPE**

This document represents the minimum requirements and specifications for the installation of an electrical underground distribution system fed from padmounted transformation, serving garden style apartments and condominiums, to be transferred to Oncor Electric Delivery Company ownership.

**2. REFERENCES**

This specification shall be used in conjunction with the latest edition of the following publications.

2.1 The Electric Service Guidelines, Oncor Electric Delivery Company.

**3. DEFINITIONS**

3.1 Company: Oncor Electric Delivery Company and its designated representatives.

3.2 Contractor: Individual or firm installing an electrical underground distribution service for garden style apartments and condominiums.

3.3 Authority Having Jurisdiction: Generally an incorporated City or Town, but may be an agency of the County, State or Federal Government.

3.4 Point of Delivery: The point where Company's conductors are connected to premise's conductors, typically at the meter socket or service enclosure.

**4. GENERAL**

4.1 The latest edition of all applicable building and safety codes shall be followed in the installation of the underground distribution system. Included, but not limited to are the:

#### **4. GENERAL** (continued)

- 4.1.1 Local City Building and Fire Codes or any other applicable codes for a particular project location
- 4.1.2 National Electrical Safety Code (NESC)
- 4.1.3 U. S. Occupational Safety and Health Act of 1970 (OSHA)
- 4.1.4 The American Concrete Institute (ACI)
- 4.1.5 The American Society for Testing and Materials (ASTM)
- 4.2 Upon receipt of all necessary information from the Contractor, a project sketch showing the route of the conduit line, the transformer pad location and other pertinent information will be furnished by the Company.
- 4.3 Prior to construction a meeting shall be held to discuss and coordinate construction and inspection.
- 4.4 The Company will require a signed easement at no cost or a filed plat incorporating Company easement requirements prior to the Company installing any electrical facilities.
- 4.5 Joint use ditch will be determined by the Company on an individual basis.
- 4.6 No electrical facilities shall be connected by the Company until after the final inspection is made and approval by the Authority Having Jurisdiction, as required by code, has been received.

#### **5. COMPANY RESPONSIBILITY-** The following shall be performed by, and the responsibility of, the Company.

- 5.1 The Company inspector is to check all conduit installations prior to the placing of backfill.
- 5.2 The Company inspector is responsible for all field changes and coordinates changes with the local Engineering office.
- 5.3 The Company inspector is to inspect all transformer pad installations prior to the laying of concrete.

## **5. COMPANY RESPONSIBILITY (continued)**

- 5.4 After approval of the installed transformer pad and conduit system by the Company inspector, and after the Contractor has signed all appropriate contracts, agreements, easements and has paid any CIAC (contribution in aid of construction), the Company shall install transformers, primary cable, and secondary and service lateral cables up to the line side of the point of delivery.
- 5.5 Upon notification of final electrical inspection from the Authority Having Jurisdiction, the Company is to make final electrical connections at the point of delivery.

## **6. CONTRACTOR RESPONSIBILITY-** The following shall be performed by, and the responsibility of, the contractor.

- 6.1 The Contractor is to provide the Company a Site Plan, a Dimension Control Plan, an Elevation Plan, a Grading Plan and load information.
- 6.2 The Contractor is to coordinate with the Company inspector for inspection of work prior to backfilling.
- 6.3 The Contractor is to provide personnel and vehicular access to the facility at all times.
- 6.4 The Contractor is to be held responsible for full direction and supervision of all work to be performed by his employees, agents or contractors. The Contractor shall also be responsible for the area at all times prior to acceptance, particularly in the prevention of damage to the electrical distribution system by the activities of other trades and utilities.
- 6.5 All testing of concrete and backfill which is deemed necessary by the Company is to be performed by an independent testing laboratory at the Contractor's expense.
- 6.6 The Contractor is to replace at his expense any damaged equipment or correct any work not in compliance with the requirements in these specifications, the project sketch, the DDS-3 UG Detail Sheets or as specified by the Company.
- 6.7 The Contractor is to furnish equipment and labor to lay out ditch, set grade, dig ditches, place conduit in ditch, set transformer pads and place electrical connection boxes. The line shall run in as straight alignment as practicable. All conduit and bends shall be Schedule 40 PVC or Schedule 80 PVC steel and shall be electrical grade. All PVC conduit and bends shall be gray in color.

## 6. CONTRACTOR RESPONSIBILITY (continued)

- 6.8 The Contractor is to complete rough site grading, establish final grade at padmounted equipment locations and clear these locations of all obstructions. Any change in final grade which requires the lowering or raising of electrical conductors or associated equipment is at the expense of the Contractor.
- 6.9 Minimum vertical crossing clearance from other utilities is twelve (12) inches.
- 6.10 A lateral separation of five (5) feet from other utilities is required on private property.
- 6.11 No foreign pipes are permitted under the transformer pad area except gas, telephone and cable T.V that are installed at the same time as the electrical facilities. Gas is allowed only if sleeved in polyethylene or Schedule 40 PVC. Telephone and cable T.V. are allowed only if installed in conduit.
- 6.12 Backfilling of conduit trenches under paved areas, around conduit bends at riser poles and under transformer pad areas is to be compacted to 95% of the density of surrounding undisturbed soil as per ASTM D 698. Stabilization must be uniform to bottom of ditch. Alternative stabilization methods for backfilling around conduit bends under transformer pad consist of two (2) sacks of cement mixed with earth backfill or the pouring of concrete backfill with transformer pad. An alternative method for backfilling around conduit bends consists of concrete backfill with bend. The method and location where used will be at the discretion of the Company.
- 6.13 Transformer pads are to be installed a minimum of three (3) inches above finished grade. No transformer pad is to be installed in a pit below the finished grade of the surrounding area.
- 6.14 Transformer pads are to have a clear area surrounding the pad installation for safety, operation and maintenance purposes. Reference DDS-3 UG Detail Sheets 23, 24, 25 and 26 for layout and dimensions.
- 6.15 Piers are required on all transformer pads unless waived by the Company inspector. The depth of piers shall extend to rock or a change in soil conditions sufficient to bear the load of pad and transformer to prevent settlement due to undercutting for conduit bend installation or washing due to drainage.
- 6.16 The Contractor has the option of installing manufactured transformer pads or poured in place pads. However, where the terrain will not permit the installation of a manufactured transformer pad as determined by the Company, the Contractor is to install a poured in place transformer pad. For details see DDS-3 UG Detail Sheet 13.

## 6. CONTRACTOR RESPONSIBILITY (continued)

- 6.17 Concrete forms are to be tight and aligned so when forms are removed the finished surface shall require little, if any, corrective measures. Concrete work is to have an acceptable finish free of honeycombs, sharp or irregular surfaces.
- 6.18 Contractor is to pull a mandrel through each conduit to check and clear blockage and leave an approved pull tape in each conduit. Pull tape shall be furnished by the party providing conduit and shall be installed by Contractor. Mandrel shall be furnished by Contractor. Conduit shall be plugged at both ends. Reference DDS-3 UG Detail Sheet 8 for approved pull tapes.
- 6.19 Approved self- contained meter sockets or approved meter packs are to be provided and installed by the Contractor. Service enclosures (when required) are to be provided by the Company and installed by the Contractor. Reference the Electric Service Guidelines for approved self- contained meter sockets. **Contact Company for approval of meter packs prior to letting bids and installing equipment.**
- 6.20 For individually metered multi-family units utilizing ganged meter sockets or approved meter packs, the Contractor is to provide and install the service lateral raceway. Company shall provide, install, connect and maintain the service lateral conductors to the line side of the ganged meter socket or to the line side of the approved meter pack.
- 6.21 For individually metered multi-family units utilizing service enclosures, the Contractor is to provide and install (1) the service lateral raceway to the service enclosure and (2) the conductors and associated raceways from the service enclosure to the line side of the meters. The Company shall provide, install, connect and maintain the service lateral conductors to the line side of the service enclosure.
- 6.22 For Secondary Service Accounts (laundry rooms, office buildings and other commercial services) fed from padmounted transformers, the Contractor is to install all meter sockets on the building(s) with the location approved by the Company and shall provide, install and maintain the conductors and associated raceways to the secondary terminals of the transformer. The Contractor shall provide compression type connectors and the Company shall install these connectors on the Contractor's conductors and connect to the secondary terminals of the transformer. Reference the Electric Service Guidelines for approved compression type connectors.
- 6.23 The Contractor is to secure inspection and approval of premise's facilities by the Authority Having Jurisdiction prior to connection of electrical facilities

## **6. CONTRACTOR RESPONSIBILITY (continued)**

6.24 Meter sockets to multi-metered locations shall be clearly and permanently marked by the Contractor on the exterior and interior of the meter socket to indicate each apartment or location served. Engraved or stamped metal, weather resistant placards shall be used on the exterior of the meter socket and be permanently affixed. Permanent marker or other acceptable method shall be used to mark the apartment or location on the inside of the meter socket (at a location other than the cover) where it can be easily read.

## **7. ACCEPTANCE**

7.1 The Company inspector shall meet with the Contractor to review the project prior to acceptance. Electrical facilities will be installed as approved by the Company inspector only after acceptance of the project.



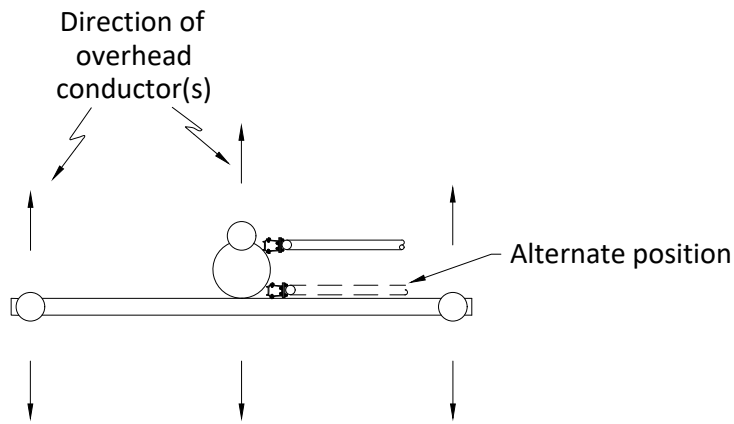

Top View

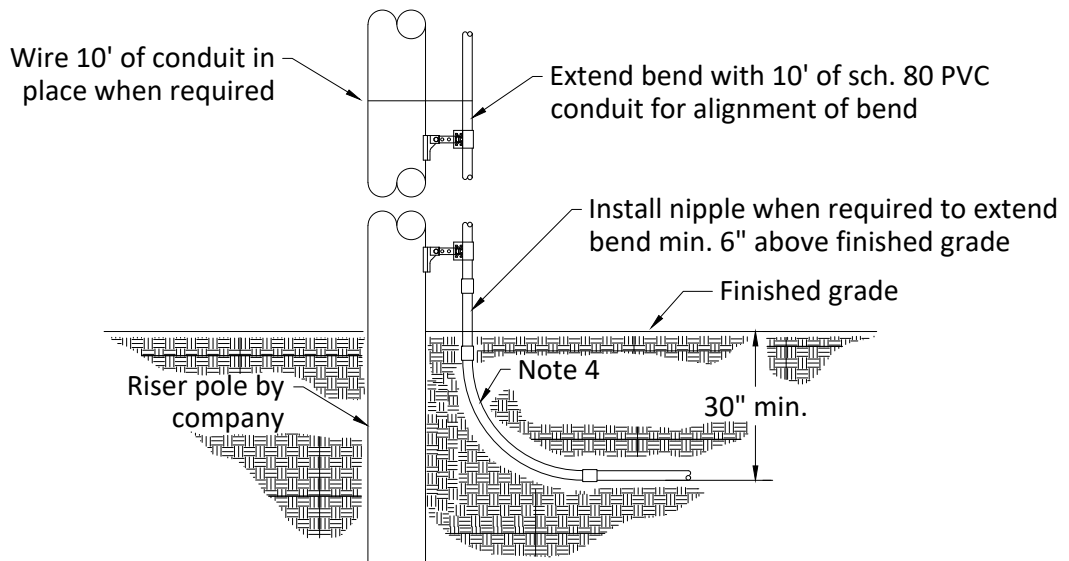

Plan View

**Notes:**

1. Contact company representative for (1) routing of conduit line, (2) size of conduit, and (3) installations requiring more than one riser on pole.
2. Limit raceway to three 90° bends. If more than three 90° bends are required, contact company representative.
3. Distance between 90° bends shall be 5' minimum.
4. Reference detail sheet 10 for bend radius for all horizontal and vertical conduit bends.



**TERMINATION OF  
PRIMARY CONDUIT  
AT RISER POLE**

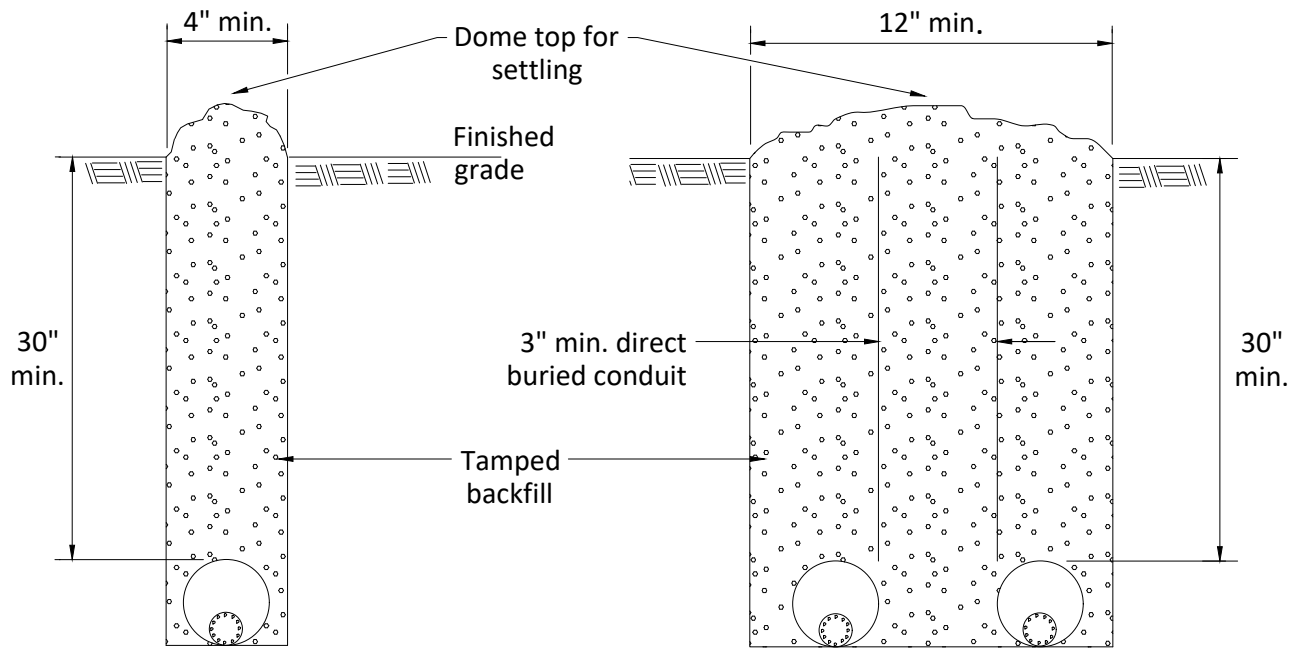

1 Primary Conduit

2 Primary Conduits

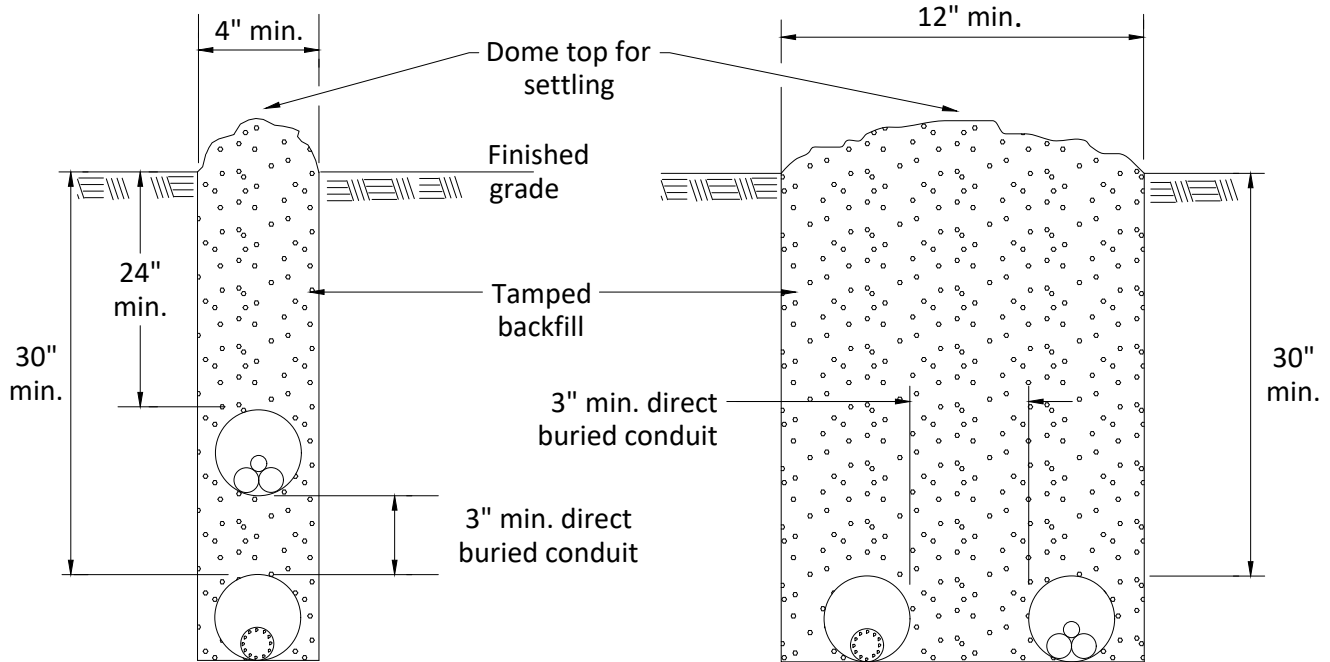

1 Primary Conduit and  
1 Secondary Conduit  
Vertically Arranged

1 Primary Conduit and  
1 Secondary Conduit  
Horizontally Arranged

**Notes:**



1. Consult company representative for conduit size.
2. See detail sheets 8 and 9 for notes and instructions.
3. Separation dimensions apply to company conduits or cables only. Maintain 12" separation between company conduits or cables and foreign conduits or cables.

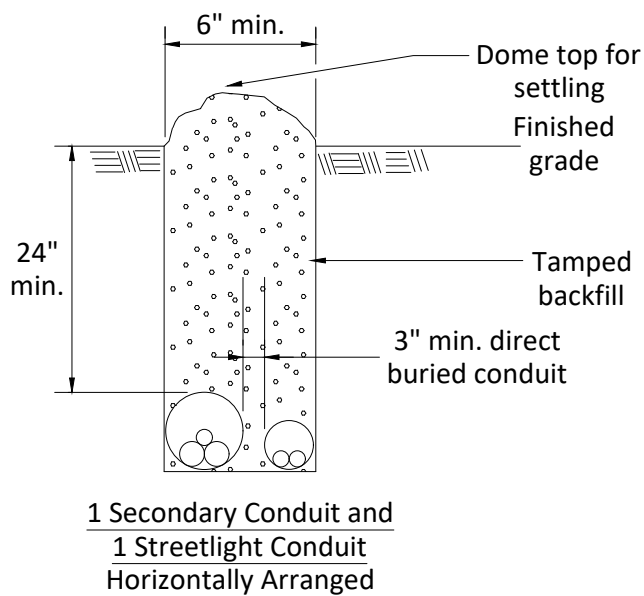
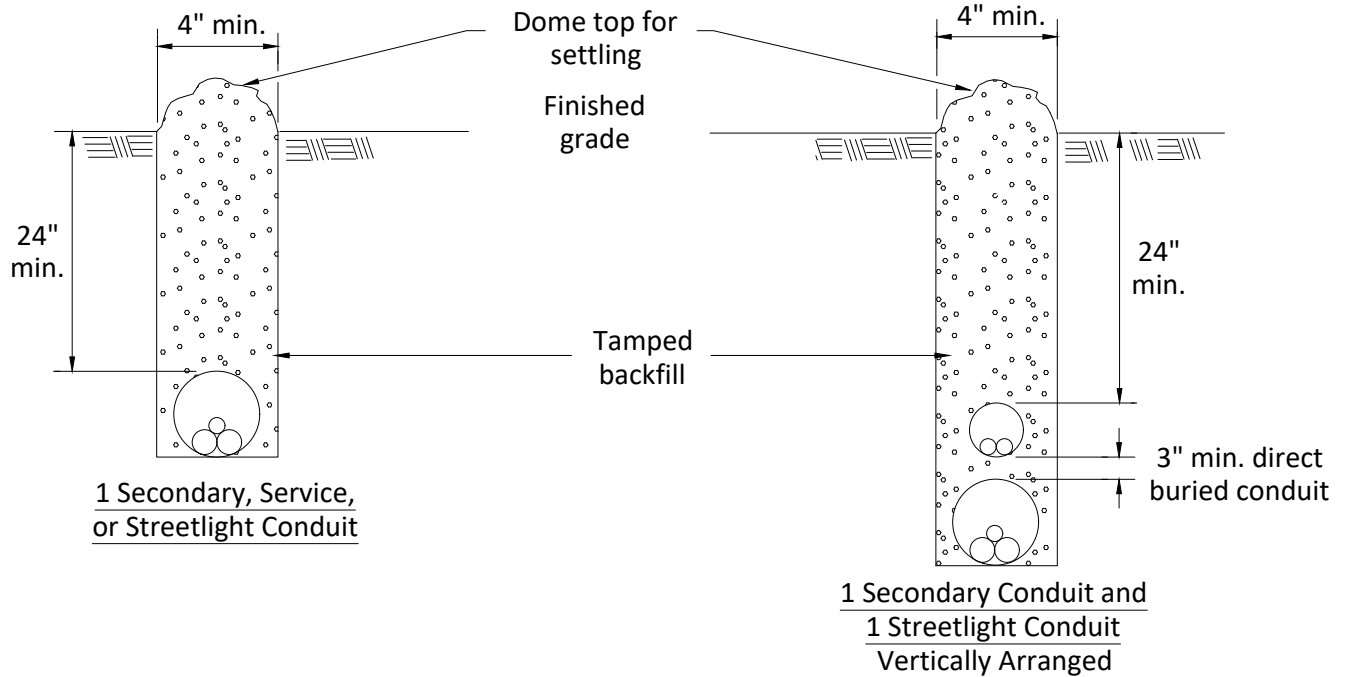

**TRENCH REQUIREMENTS**



Legend:

-  Primary Cable
-  Secondary/Service Cable
-  Streetlight Cable

Notes:

1. Consult company representative for conduit size.
2. Reference sheets 8 and 9 for notes and instructions.
3. Separation dimensions apply to company conduits or cables only. Maintain 12" separation between company conduits or cable and foreign conduits or cable.



TRENCH REQUIREMENTS

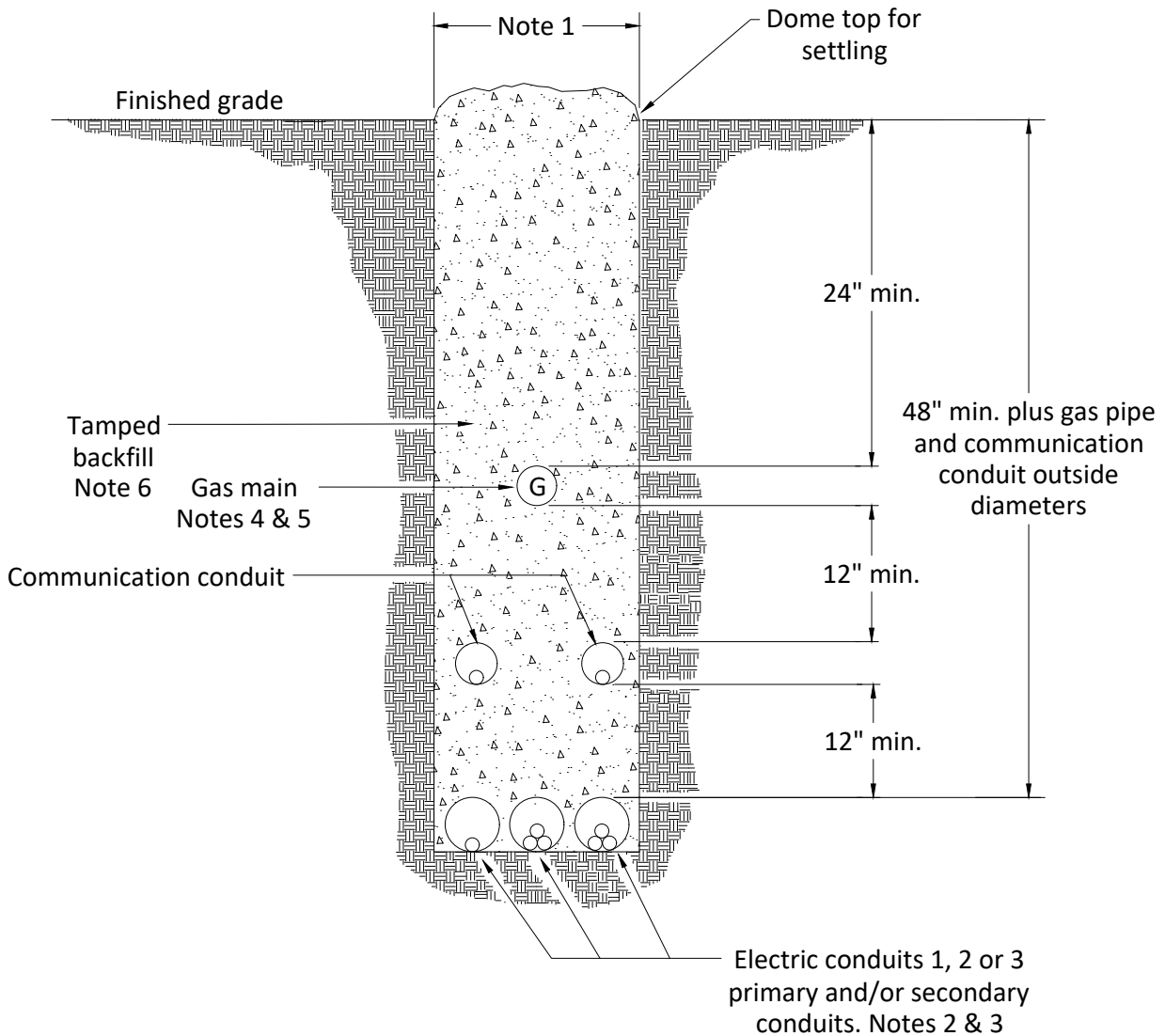

**Notes:**

1. 12" min. with more than one electrical supply conduit.  
4" min. with one electrical supply conduit (in solid rock pipe diameter determines min. width).
2. Ampacities are reduced for multiple circuits in a trench.
3. See detail sheets 8 and 9 for notes and instructions.
4. The gas line in a joint trench shall be polyethylene.
5. When a gas line crosses under an enclosure such as a pedestal, pad mount transformer or splice/pull box, it will be sleeved in a section of polyethylene or schedule 40 PVC. The sleeve will extend a minimum of 3' beyond the edge of the enclosure on each side. Maintain a 12" separation between gas line and electrical supply conduit(s).
6. Backfill material and compaction shall meet or exceed each utility's specifications.



**TRENCH REQUIREMENTS  
JOINT USE ELECTRIC, GAS  
AND COMMUNICATION**

**DDS-3 UG DETAIL SHEET 4 OF 32**

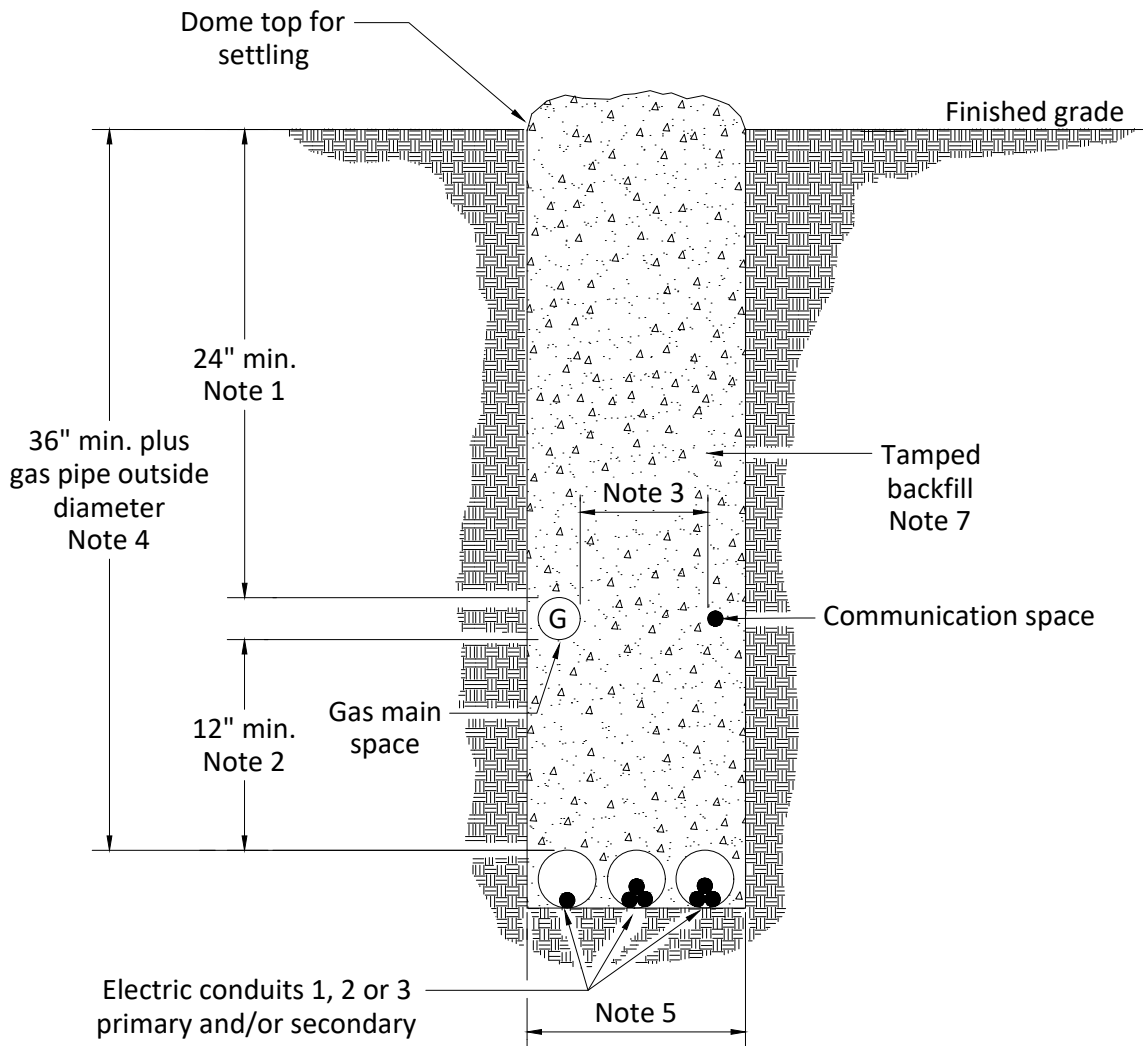

**Notes:**

1. Minimum 24" depth to top of both gas pipe and communication facilities. Communication shall not be placed above the gas pipe.
2. Minimum 12" vertical separation between surface of gas, communication facilities and electrical conduits.
3. Minimum 12" horizontal separation between surface of communication facilities and gas pipe.
4. Minimum 36" depth plus pipe outside diameter to top of electrical conduits.
5. Trench must be wide enough to ensure 12" separation at all points between the gas main and communication facilities.
6. The gas pipe shall only be placed against undisturbed soil that is free of stones and where there are no hard particles larger than 1/2".
7. Backfill material and compaction shall meet or exceed each utility's specifications.
8. See sheets 8 and 9 for notes and instructions.



**JOINT USE TRENCH WITH  
GAS, ELECTRIC  
AND COMMUNICATION**

**DDS-3 UG DETAIL SHEET 5 OF 32**

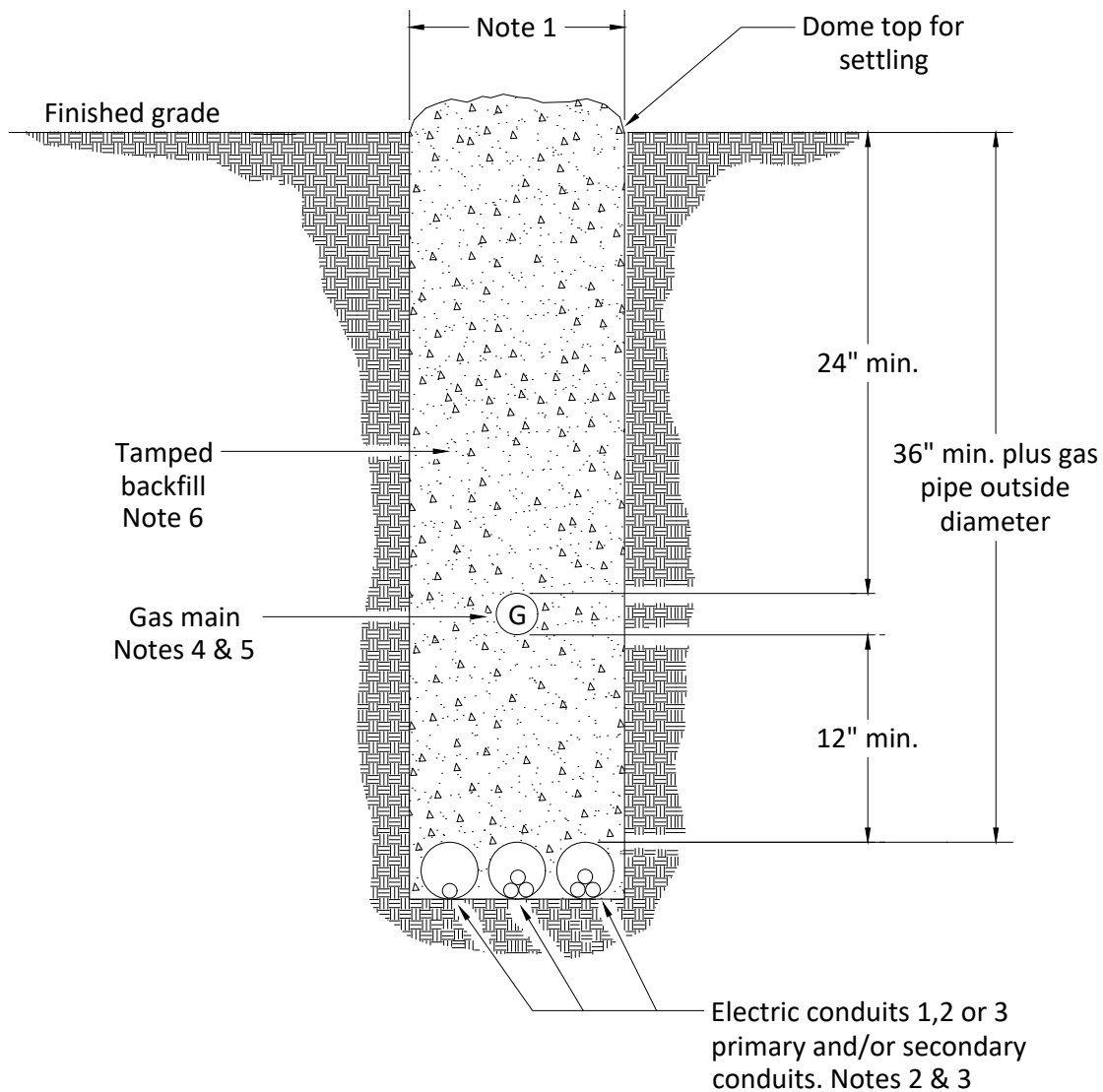

**Notes:**

1. 12" min. with more than one electrical supply conduit.  
4" min. with one electrical supply conduit (in solid rock pipe diameter determines min. width).
2. Ampacities are reduced for multiple circuits in a trench.
3. See detail sheets 8 and 9 for notes and instructions.
4. The gas line in a joint trench shall be polyethylene.
5. When a gas line crosses under an enclosure such as a pedestal, pad mount transformer or splice/pull box, it will be sleeved in a section of polyethylene or schedule 40 PVC. The sleeve will extend a minimum of 3' beyond the edge of the enclosure on each side. Maintain a 12" separation between gas line and electrical supply conduit(s).
6. Backfill material and compaction shall meet or exceed each utility's specifications.



**TRENCH REQUIREMENTS  
JOINT USE ELECTRIC AND GAS**

**DDS-3 UG DETAIL SHEET 6 OF 32**

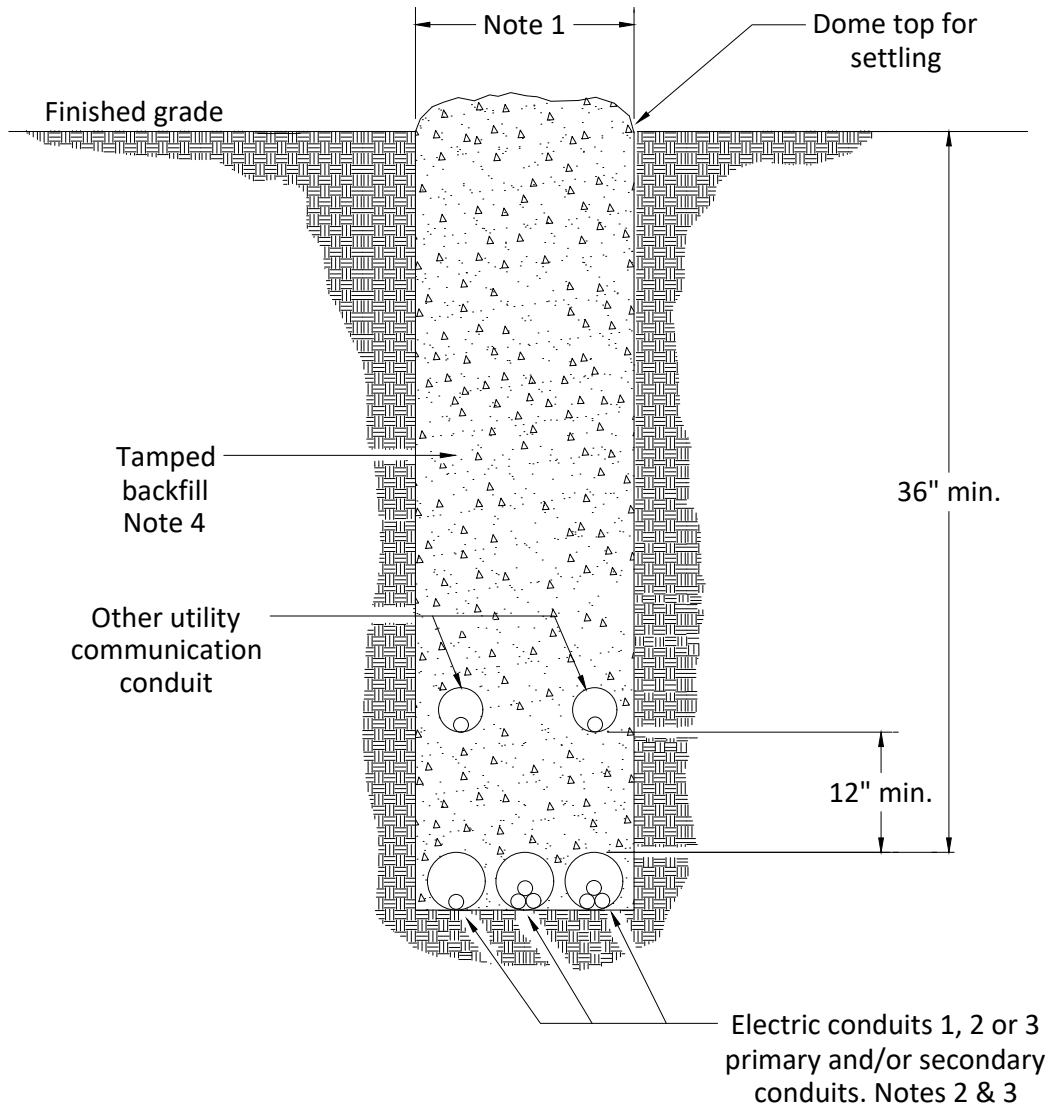

**Notes:**

1. 12" min. with more than one electrical supply conduit.  
4" min. with one electrical supply conduit (in solid rock pipe diameter determines min. width).
2. Ampacities are reduced for multiple circuits in a trench.
3. See detail sheets 8 and 9 for notes and instructions.
4. Backfill material and compaction shall meet or exceed each utility's specifications.



**TRENCH REQUIREMENTS  
JOINT USE  
ELECTRIC AND COMMUNICATION**

**DDS-3 UG DETAIL SHEET 7 OF 32**

1. Trench alignment shall be as straight as conditions permit. Any deviations from planned alignment shall have prior approval by the project engineer/inspector. All trench cuts shall be in accordance with existing safety regulations in effect.
2. Trench bottom should be undisturbed, tamped, or relatively smooth earth. Where excavation is in rock, the conduit should be laid on a layer of clean backfill.
3. All backfill should be free of debris or other material that may damage the conduit system or cause settling. The material should fill the voids around the conduit to prevent hot spots and settling.
4. Backfill should be adequately compacted. Backfill not under pavement should be compacted to the density of the surrounding undisturbed soil. Backfill under pavement should be compacted to not less than 95% of the density of undisturbed soil as determined by ASTM D698.
5. See sheet 9 for instructions for joining PVC conduit.
6. Each conduit run shall be checked by pulling a mandrel through the entire length at the completion of the civil installation.
7. A pull tape shall be left in each conduit. Conduit shall be plugged at both ends.

Approved Pull Tapes			
Conduit Size	Manufacturer	Catalog No.	TSN
1", 2" & 3"	Arnco Neptco, Inc.	BL-WP25 WP2500P	321068
4" & 6"	Arnco Neptco, Inc.	BL-WP60 RP6000N	397616

8. Contact company representative for trench dimensions for more than 2 conduits in same ditch.



**INSTALLATION OF CONDUITS  
NOTES AND INSTRUCTIONS**

**DDS-3 UG DETAIL SHEET 8 OF 32**



The chemicals used in solvent welding of conduit are intended to penetrate the surface of both pipe and fitting, which after curing result in a complete fusion at the joint. The over-use or under-use of chemicals results in leaky joints or weakened pipe.

1. Clean conduit by wiping off all dust, dirt and moisture from surfaces to be cemented either by mechanical or chemical cleaning.
  - 1.1. Mechanical cleaning - Fine abrasive paper or cloth (180 grit or finer) or clean oil-free steel wool.
  - 1.2. Chemical cleaning- Cleaner recommended by manufacturer or equivalent (methyl ethyl ketone - Mek).
2. With a non-synthetic bristle brush apply an even coating of cement to the outside of the pipe and inside the socket. Make sure that the amount of cement applied to the conduit is equal to the depth of the socket. Before assembly, if some evaporation of solvent from the surfaces to be joined is noted, reapply cement, then assemble.

If cement being used has an appreciable change in viscosity or shows signs of jelling, it shall be discarded. In no case shall thinner be used in an attempt to restore jelled PVC cement. Thinner may only be used to change the viscosity of a medium bodied cement to that of a regular bodied cement for application on PVC pipe smaller than 2 1/2" diameter. A medium bodied cement shall be used on 2 1/2" to 6" PVC pipe.

Use a primer to soften the joining surfaces before applying cement. Allow longer cure time. (See item 5).

3. Join pipe within 20 seconds of applying cement. Turn the pipe 1/4 turn to ensure even distribution of cement on surfaces to be bonded. Make sure that pipe is inserted to the full depth of the socket.
4. Clean off any bead or excess cement that appears at the outer shoulder of the fitting. Excess cement allowed to remain in contact with the material is apt to cause weakening of the material, and subsequent failure.
5. Newly assembled joints should be handled carefully until the cement has cured to the recommended set period. Set periods are related to the ambient temperature as follows:

- 30 min. minimum at 60° to 100° F
- 1 hr. minimum at 40° to 60° F
- 2 hr. minimum at 20° to 40° F
- 4 hr. minimum at 0° to 20° F



## INSTRUCTIONS FOR JOINING PVC CONDUIT

**DDS-3 UG DETAIL SHEET 9 OF 32**

Conduit Nominal Size (in.)	Minimum Bend Radius (in.)	Type of Bend Material for Pulls:
1	18	PVC
2	24	PVC
3	24	PVC
4	36 (See notes 3 & 4)	PVC
6	36	PVC

Notes:

1. Sch. 80 PVC conduit shall be used for all above ground installations (pole and meter risers). Sch. 40 may be used for all below ground installations.
2. No field bends.
3. 24" sweep 90s on 4" PVC may be used when the required conduit depth is less than 30" from final grade.
4. 24" sweep 90s on 4" PVC may be used on primary applications when a proper depth of the conduit can not be attained under a deep well pad or deep window application.

(The complete 90 must be below final grade or the pad window)



**CONDUIT BEND RADIUS  
AND MATERIAL**

**DDS-3 UG DETAIL SHEET 10 OF 32**

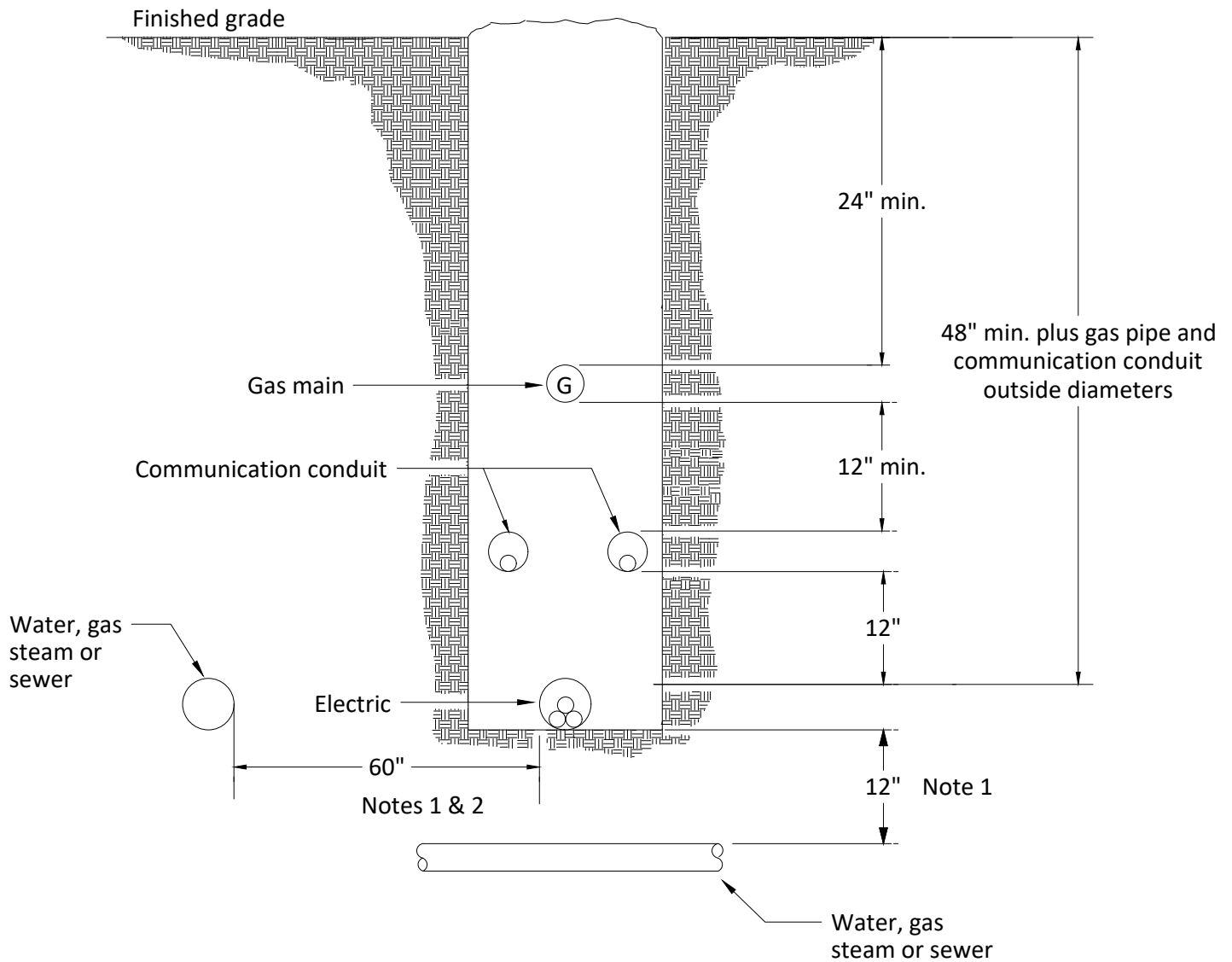

**Notes:**

1. Vertical crossing clearance from other utilities shall be 12". A 60" lateral separation of paralleling foreign utilities (excluding gas and communications) shall be required. An exception would be to allow gas, telephone and/or CATV in the same ditch as company conduit system providing the NESC requirements for conduit separation are met or exceeded and the communications circuits are installed in conduit.
2. It is understood that only 12" separation is required on public rights-of-way. Personnel involved in excavation on public rights-of-way are fully aware of the hazards involved. However, excavation on private property can be done by individuals who are not likely to be fully aware of the hazards. Therefore, the 60" lateral separation is required to help prevent injury to personnel doing excavation on private property.



**CLEARANCE REQUIREMENTS  
FROM FOREIGN UTILITIES  
ON PRIVATE PROPERTY**

**DDS-3 UG DETAIL SHEET 11 OF 32**

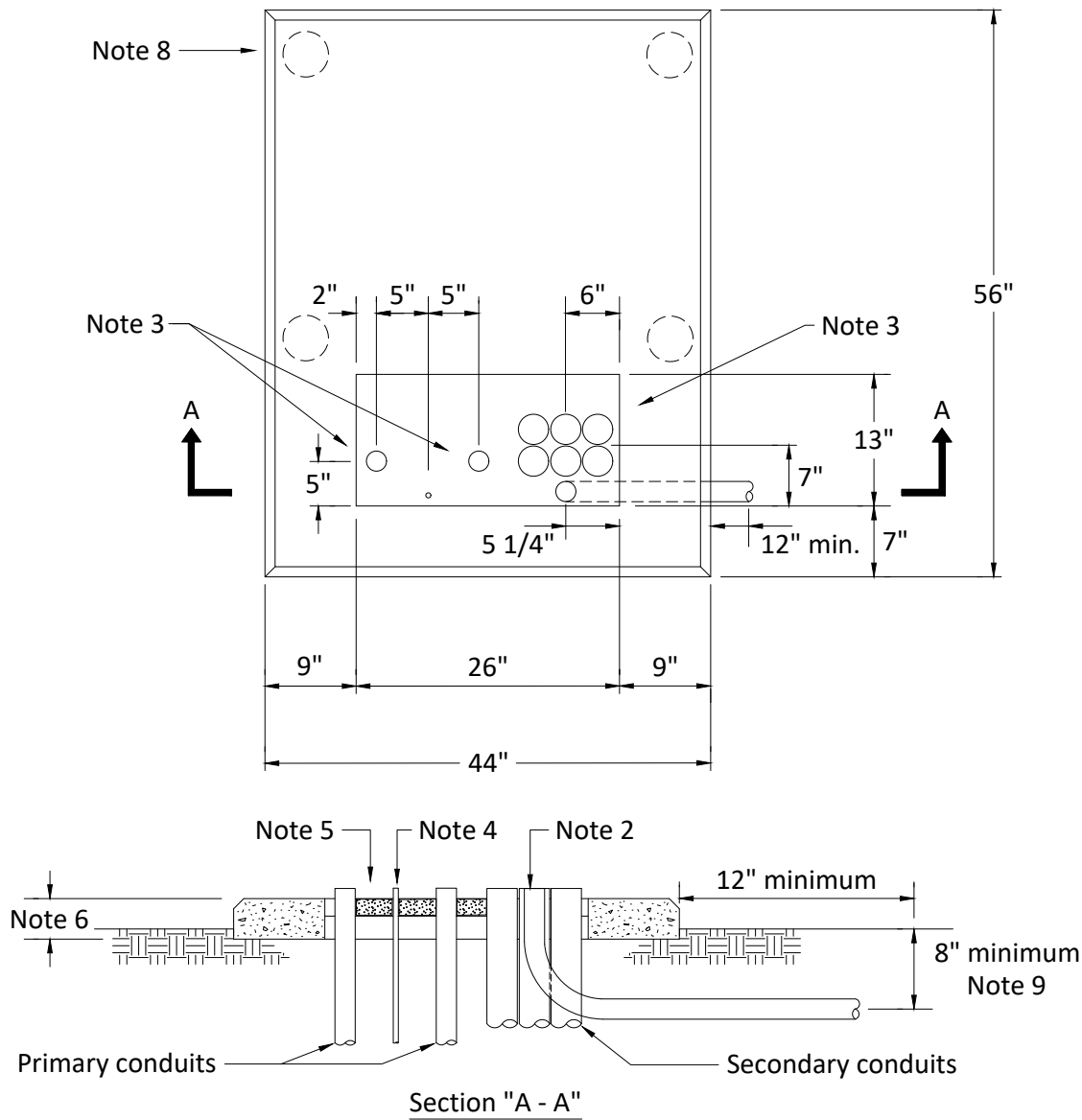

Notes:

1. Consult company representative for (1) number, size and location of conduits in pad window and (2) whether design is type I or type II conduit arrangement.
2. No more than 8 - 2", 6 - 3" or 4 - 4" conduits including spares shall be placed in the secondary side of pad window.
3. Reference detail sheet 10 for bend radius for all horizontal and vertical conduit bends.
4. Consult company representative on where to obtain 5/8" x 8' copper clad ground rod. Ground rod to be obtained and installed by contractor. Installation depth shall be 7' - 6".
5. Grout window as per detail sheet 14.
6. The dimension is 6" for precast concrete pad and 4" for polymer concrete pads.
7. Reference detail sheet 15 for foreign utility equipment ground.
8. Piers are required on all pads unless waived by company inspector. Reference detail sheet 20 for pier detail.
9. The 3" flex conduit shall have a minimum of 8" of cover as it exits on the right hand side of the transformer pad.



**TRANSFORMER PAD-PRECAST  
SINGLE-PHASE DEAD FRONT  
TYPE I**

**DDS-3 UG DETAIL SHEET 12 OF 32**

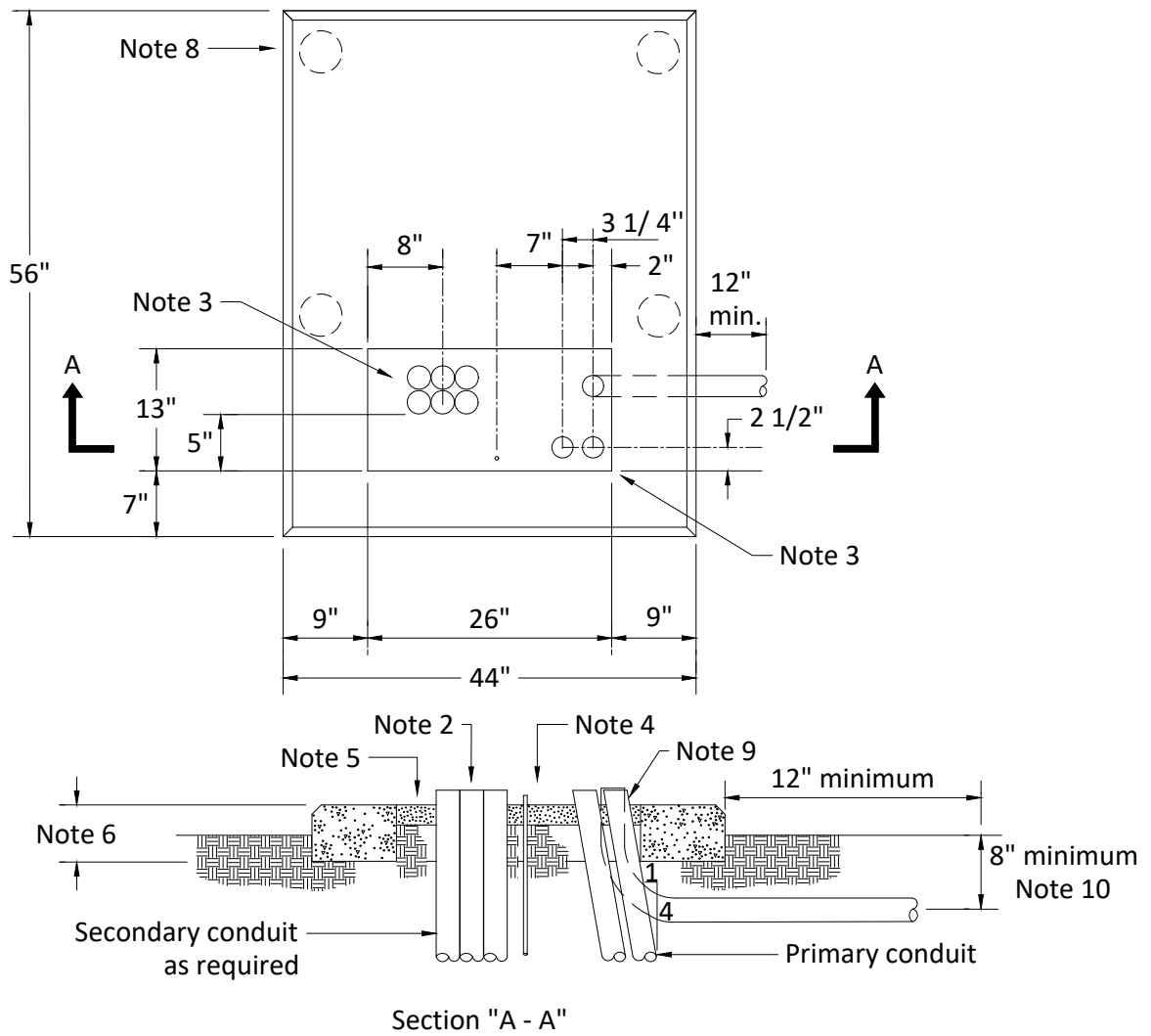

**Notes:**

1. Consult company representative for (1) number, size and location of conduits in pad window and (2) whether type I or type II conduit arrangement.
2. No more than 8 - 2", 6 - 3" or 4 - 4" conduits including spares shall be placed in the secondary side of pad window.
3. Reference detail sheet 10 for bend radius for all horizontal and vertical conduit bends.
4. Consult company representative on where to obtain 5/8" x 8' copper clad ground rod. Ground rod to be obtained and installed by contractor. Installation depth shall be 7' - 6".
5. Grout window as per detail sheet 14.
6. This dimension is 6" for precast concrete pad and 4" for polymer concrete pads.
7. Reference detail sheet 15 for foreign utility equipment ground.
8. Piers are required on all pads unless waived by company inspector. Reference detail sheet 20 for pier detail.
9. The conduits must be installed to ensure that the total maximum bending radius for the primary cable does not exceed 9" (angle primary conduit whenever possible).
10. The 3" flex conduit shall have a minimum of 8" of cover as it exits on the right hand side of the transformer pad.



**TRANSFORMER PAD-PRECAST  
SINGLE-PHASE DEAD FRONT  
TYPE II**

**DDS-3 UG DETAIL SHEET 13 OF 32**

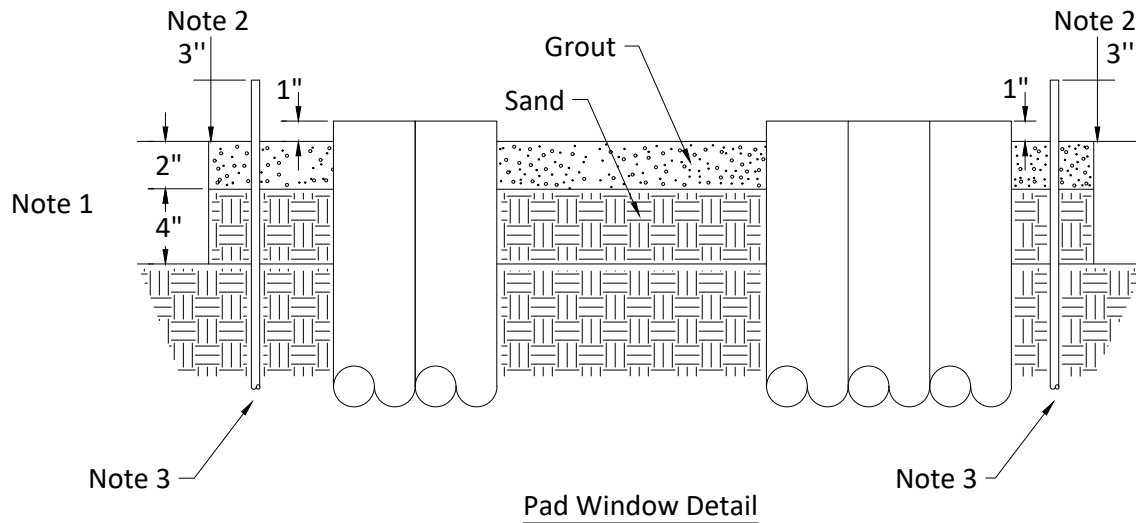
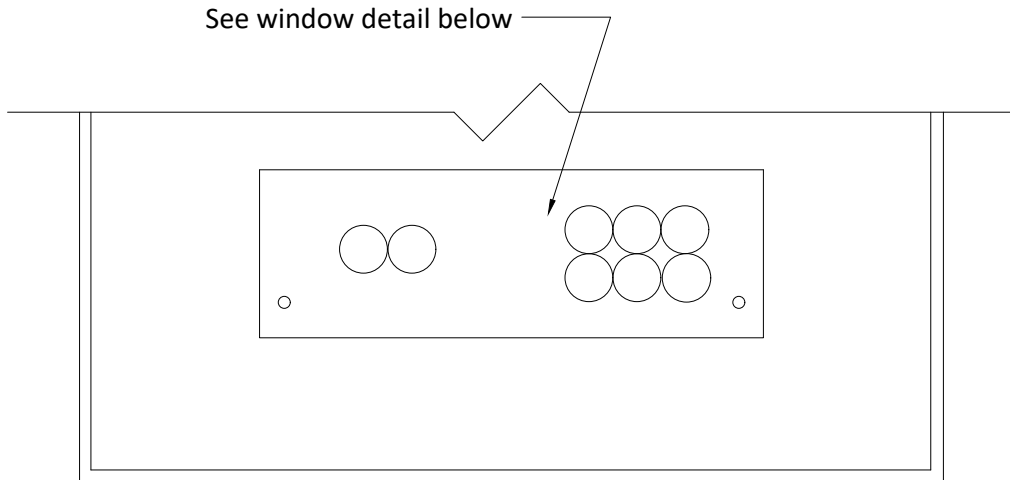

Notes:

1. The grout shall be portland based and sanded. Do not use concrete.
2. Fill in pad window with 4" of earth backfill and 2" of grout.
3. Ground rods shall extend a maximum of 3" above grouting to assure adequate driven depth and allow for adequate connecting space.
4. Ground rods shall extend a minimum of 7' - 6" into earth.
5. Gravel fill is not acceptable.



**GROUTING DETAIL  
FOR TRANSFORMER  
PAD WINDOWS**

**DDS-3 UG DETAIL SHEET 14 OF 32**

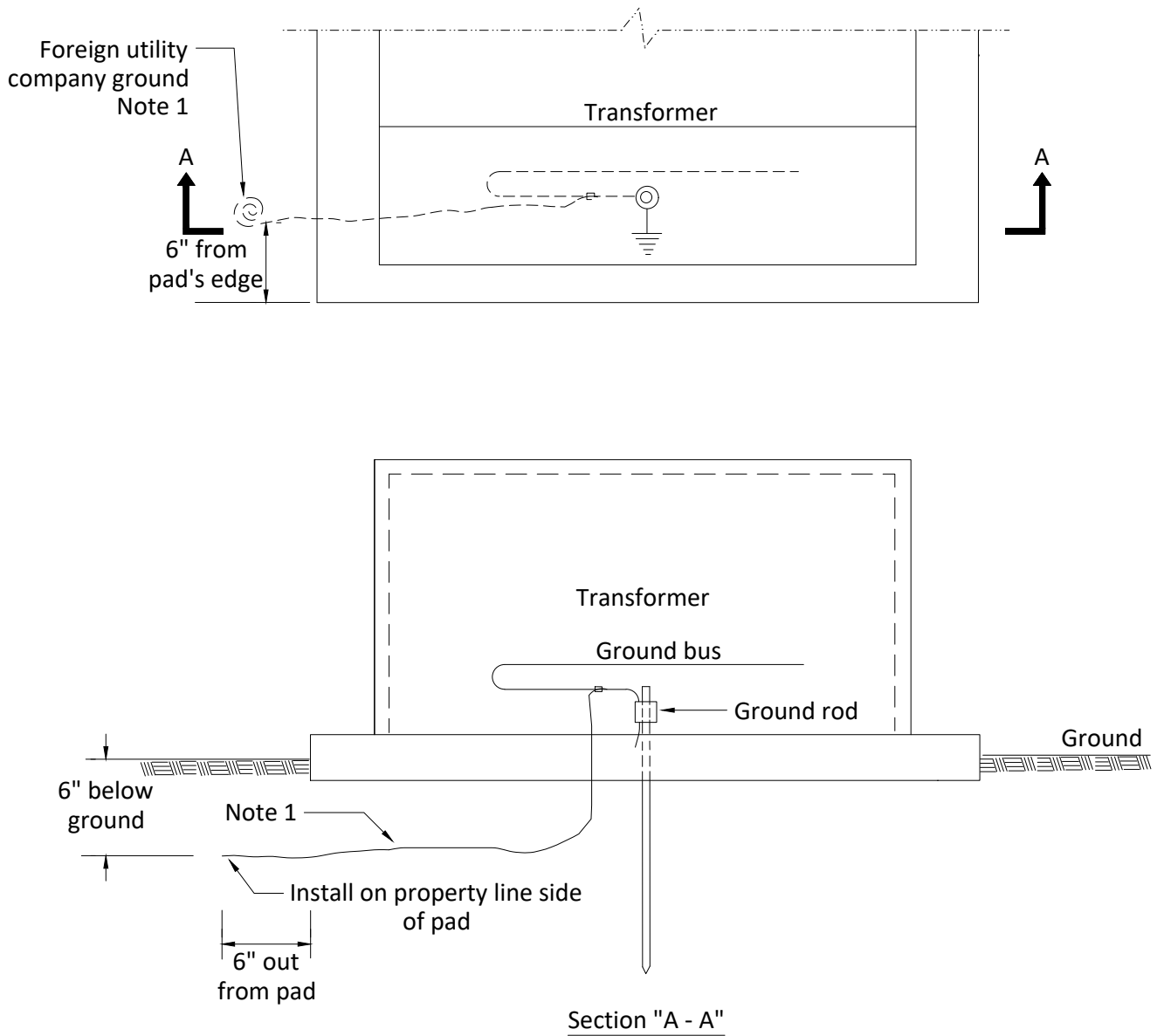

Notes:

1. On new installations, install #6 s.d. bare copper as shown for foreign utility company bonding.
2. The national electrical safety code rule 384 C recommends bonding of all above ground metallic power and communications apparatus (pedestals, terminals, apparatus cases, transformer cases, etc.) that are separated by a distance of 6' or less.



**METHOD OF PROVIDING  
UTILITY COMPANY  
EQUIPMENT GROUND**

**DDS-3 UG DETAIL SHEET 15 OF 32**

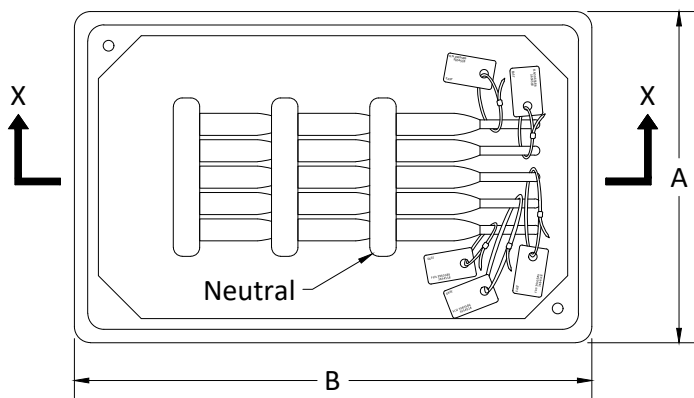

Plan View - with Cover  
Removed

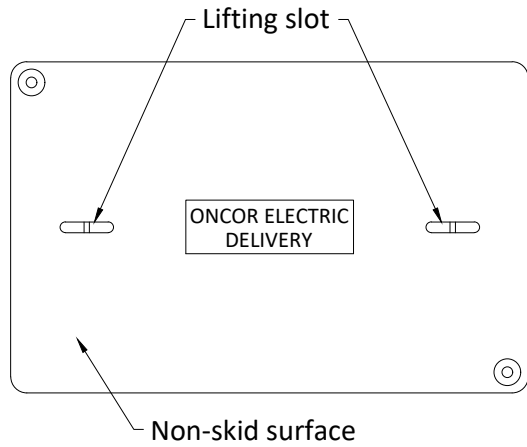

Top View - Cover

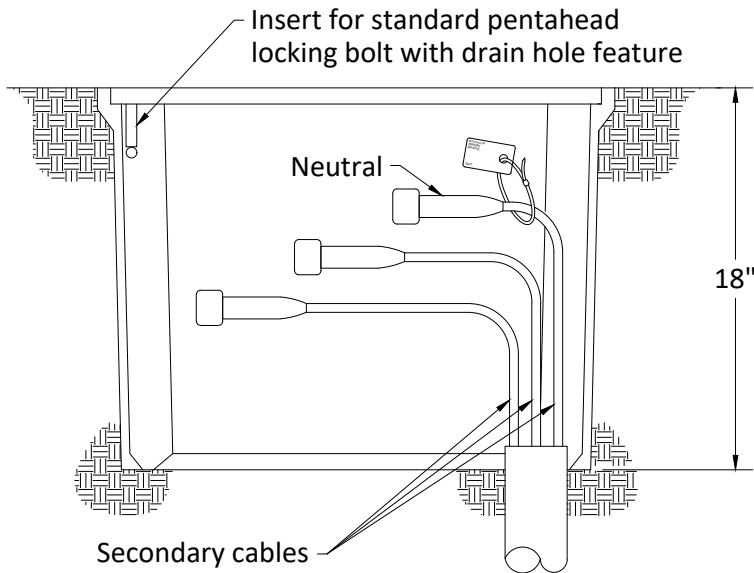

Section "X - X"

Box Size (in.)	Overall Dim. (in.)		Max. No. Circuits
	A	B	
17 x 30	20	33	8

Box Size (in.)	Replacement Lid TSN
13 x 24	326506
17 x 30	326509

Notes:

1. Consult company representative for (1) approved precast secondary subsurface boxes, (2) size of conduit, and (3) routing path of conduit into secondary subsurface box.
2. For installation of conduit to in-service secondary subsurface boxes, consult company representative for details.
3. Reference detail sheet 10 for bend radius for all horizontal and vertical conduit bends.



**TYPICAL SERVICE AREA-  
SUBSURFACE  
SECONDARY/SERVICE BOX**



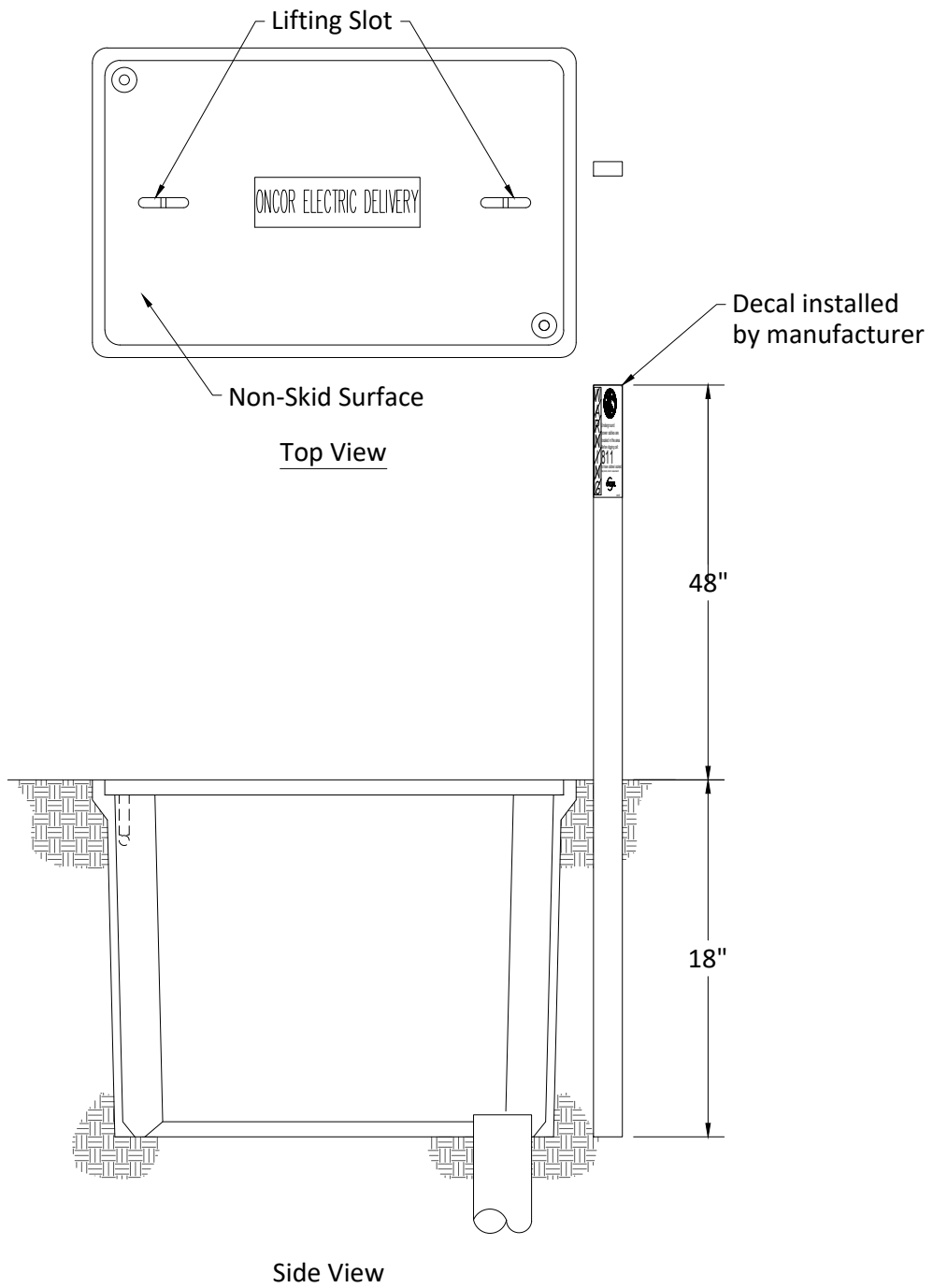

**Notes:**

1. Consult company representative on where to acquire marker stake.
2. Install marker stake within 3" of one end of subsurface box when box is being installed.
3. Remove marker stake when the last permanent meter is set.



**MARKER STAKE  
FOR  
SECONDARY/SERVICE BOX**

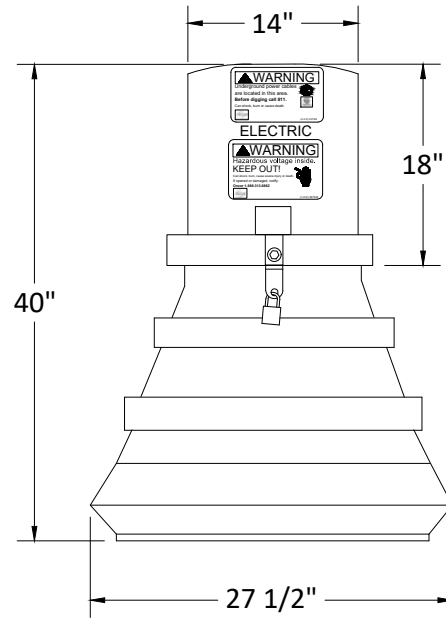
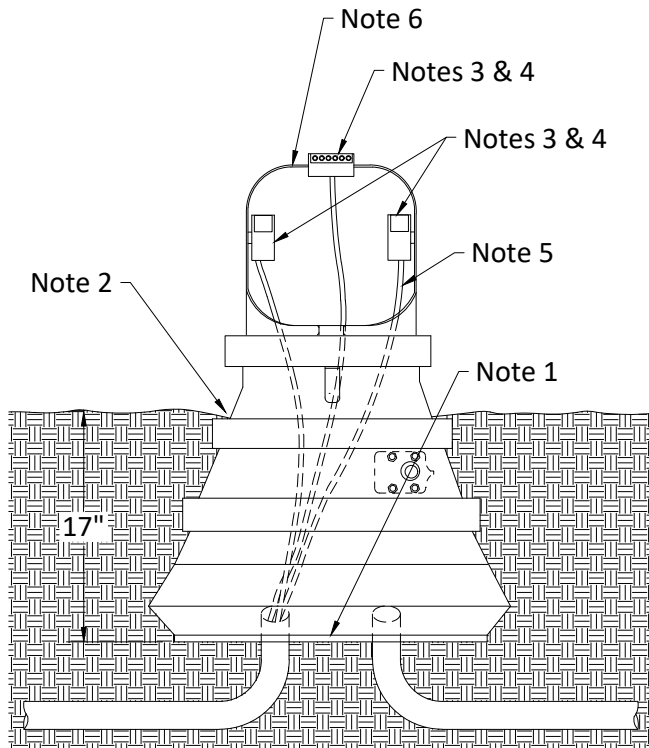

Replacement Parts	
Part	TSN
6 position connector #6 - 350 conductor	397461
6 position connector #4 - 500 conductor	397463
Clear lexan connector cover	397462
Cover tie	479418

**Installation notes:**

- Center the cables/conduits in the bottom opening of the pedestal.
- Bury the pedestal to the ground line marker and tamp the soil around the unit to secure it in the upright position.
- The connector cover is a reusable item. If missing or damaged replace with parts as shown. All connector covers shall be secured with ties. If the ties are cut or damaged in any way, replace with stock replacement parts as shown.
- Use the center top mounted connector for the neutral conductor. Use the side mounted connectors for the "hot" conductors.
- Position, cut and remove cable insulation. For good set screw compression on the conductors, extend bare conductor 1/4" above the connector. Brush conductors to remove oxide before installing in connector and apply inhibitor to cable and setscrew threads.
- Locate pedestal to minimize chance of pedestal being struck by vehicular traffic.
- Consult company representative for (1) approved secondary pedestals, (2) size of conduit, and (3) routing path of conduit into secondary pedestal.
- For installation of conduit to in-service secondary pedestals, consult company representative for details.
- Reference detail sheet 10 for bend radius for all horizontal and vertical conduit bends.



**TYPICAL SERVICE AREA-  
SINGLE PHASE  
SECONDARY PEDESTAL**

**DDS-3 UG DETAIL SHEET 18 OF 32**

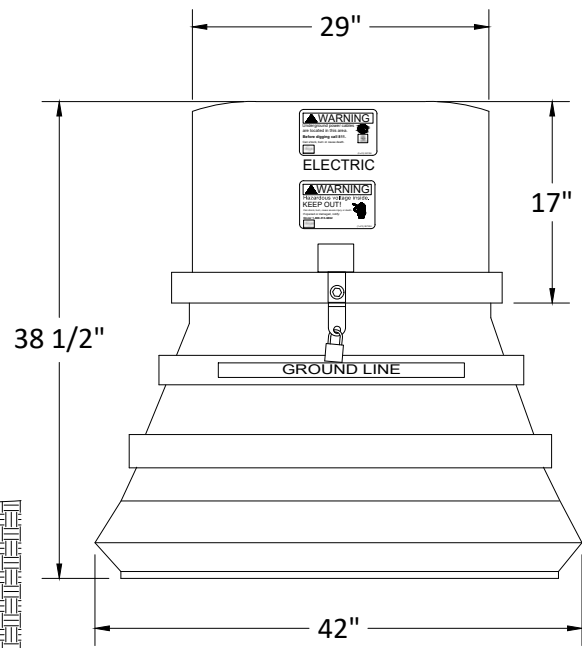
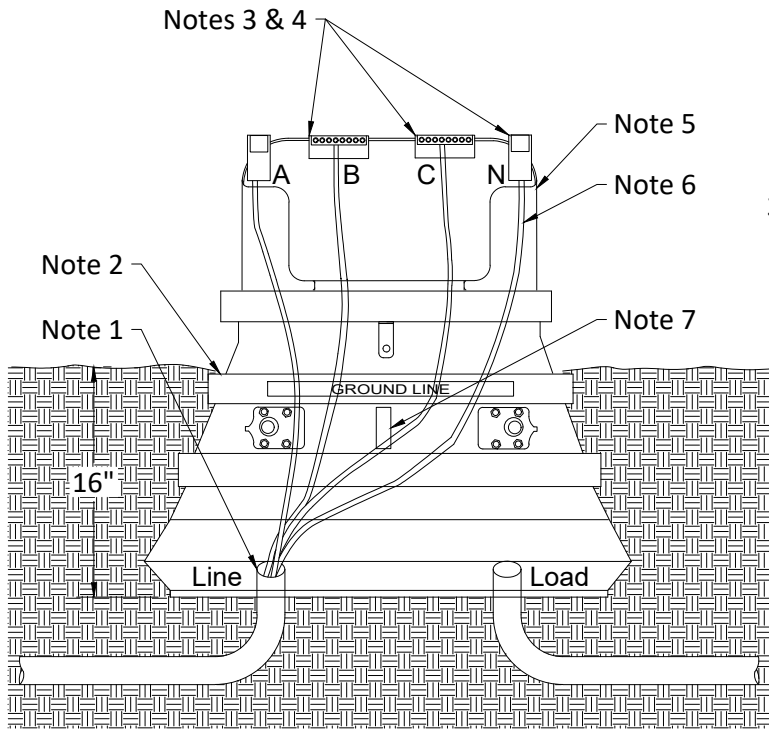

Replacement Parts	
Part	TSN
8 position connector #6 - 500 conductor with clear flexible connector cover	476321

**Installation notes:**

- Center the cables/conduits in the bottom opening of the pedestal as shown.
- Bury the pedestal to the ground line marker and tamp the soil around the unit to secure it in the upright position.
- The connector cover is a reusable item. If missing or damaged replace with stock replacement part.
- Use a clockwise phase rotation with the mounted cable connectors. Position the "A" phase connections at the 9:00, "B" phase at 11:00, "C" phase at 1:00 and the neutral at 3:00 as shown.
- Locate pedestal to minimize chance of pedestal being struck by vehicular traffic.
- Position, cut and remove cable insulation. For good set screw compression on the conductors, extend bare conductor 1/4 inches above the connector. Brush conductors to remove oxide before installing in connector and apply inhibitor to cable and setscrew threads.
- 2" x 4" wood brace has been installed to prevent the pedestal from collapse during installation compaction. After the installation is complete, cut to remove if necessary. If brace is not a space conflict, leave it in place.
- Consult company representative for (1) approved secondary pedestals, (2) size of conduit, and (3) routing path of conduit into secondary pedestal.
- For installation of conduit to in-service secondary pedestals, consult company representative for details.
- Reference detail sheet 10 for bend radius for all horizontal and vertical conduit bends.



**TYPICAL SERVICE AREA-  
SINGLE PHASE  
SECONDARY PEDESTAL**

**DDS-3 UG DETAIL SHEET 19 OF 32**

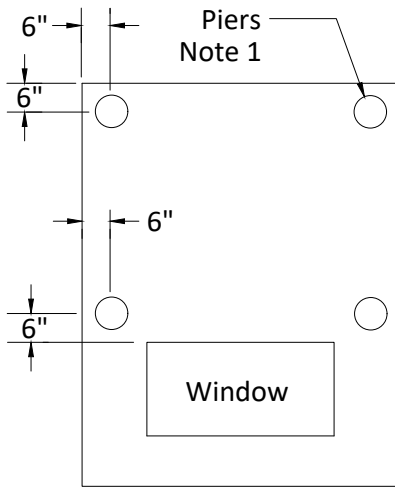

Transformer Pad

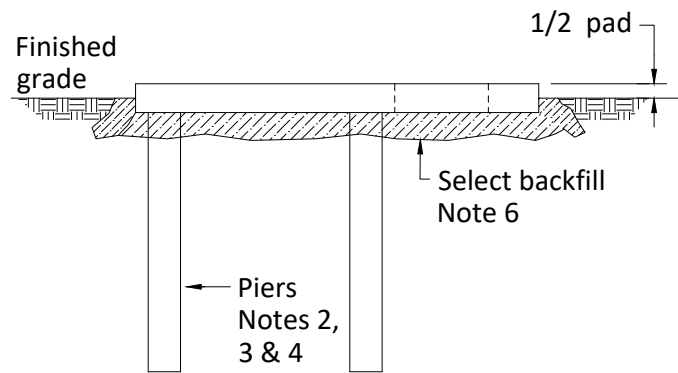

Side View for Level Terrain

**Notes:**

1. Piers shall be installed under pad when dirt has been disturbed under the load bearing area of pad. Tamp backfill (95% compaction) to top of pier supports (use ditch spoil when possible).
2. Cut support piers from section of 4" PVC conduit.
3. Place piers as shown. Fill with concrete.
4. Top of piers should be level and 3" below final ground level to a depth of:
  - (1) Minimum of 36" in undisturbed earth (soil).
  - (2) Bottom of ditch.
  - (3) Beginning of solid rock.
5. After placing pad, fill voids under and around pad with select ditch spoil.
6. All backfill under and around pad shall be well tamped.



**SINGLE-PHASE TRANSFORMER PAD  
PIER INSTALLATION**

**DDS-3 UG DETAIL SHEET 20 OF 32**

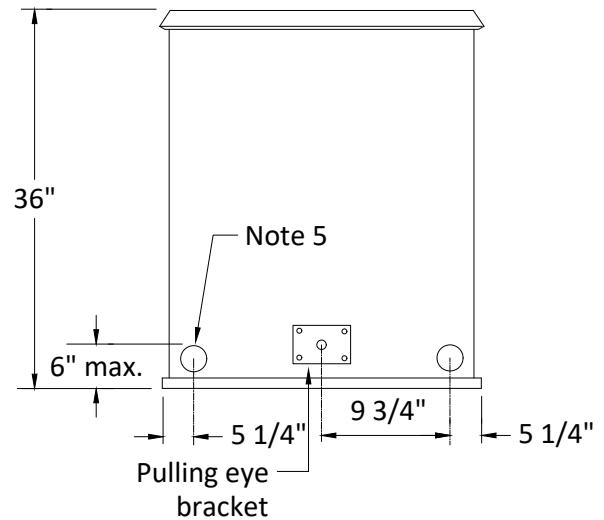
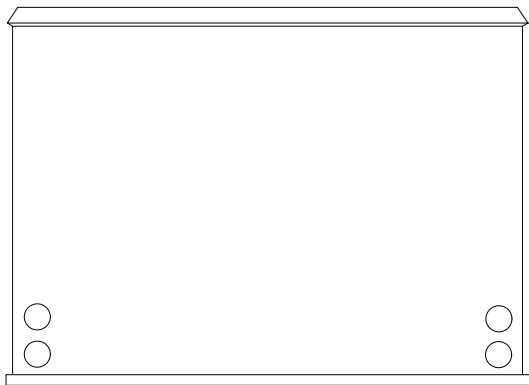
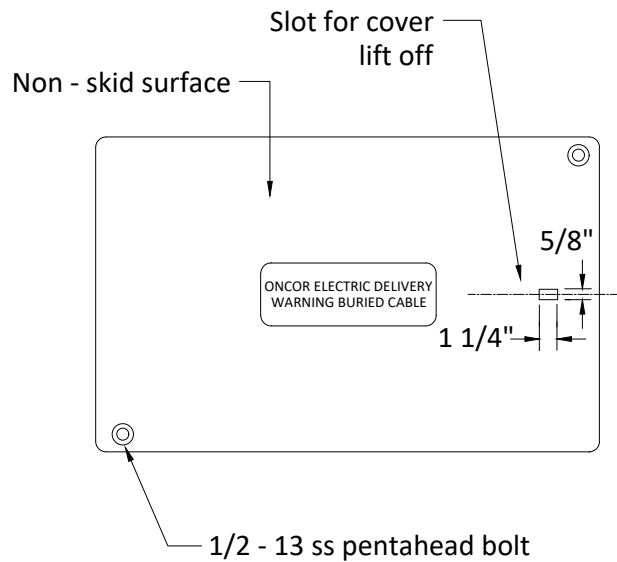
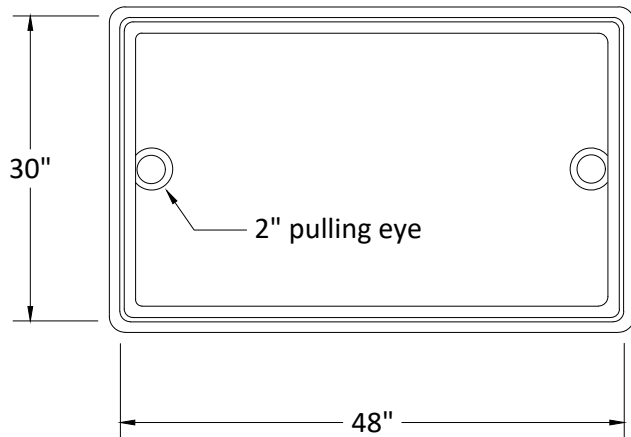

**Notes:**

1. Polymer concrete pull box has an ANSI TIER-15 vertical design loading (light vehicular rollover).
2. Precast concrete pull box has an AASHTO H-20 vertical design loading (heavy vehicular rollover).
3. Number and location of pentahead bolts and lifting provisions may vary among manufactures.
4. Limit to 1 phase of 1/0 conductor.
5. 2 1/2" diameter knockout provision for 2" conduit terminator.



**SINGLE-PHASE PRIMARY  
SUBSURFACE SPLICE/PULL BOX  
INSTALLATION**

**DDS-3 UG DETAIL SHEET 21 OF 32**

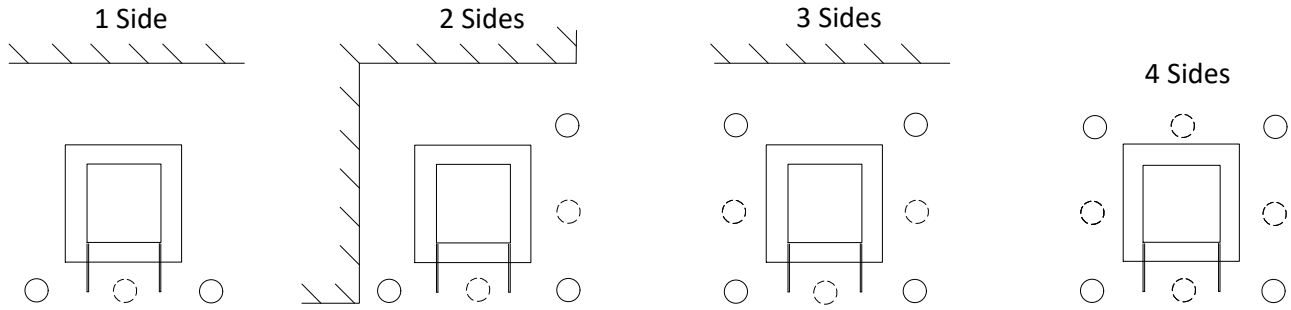

Typical Layout for Traffic and Parking

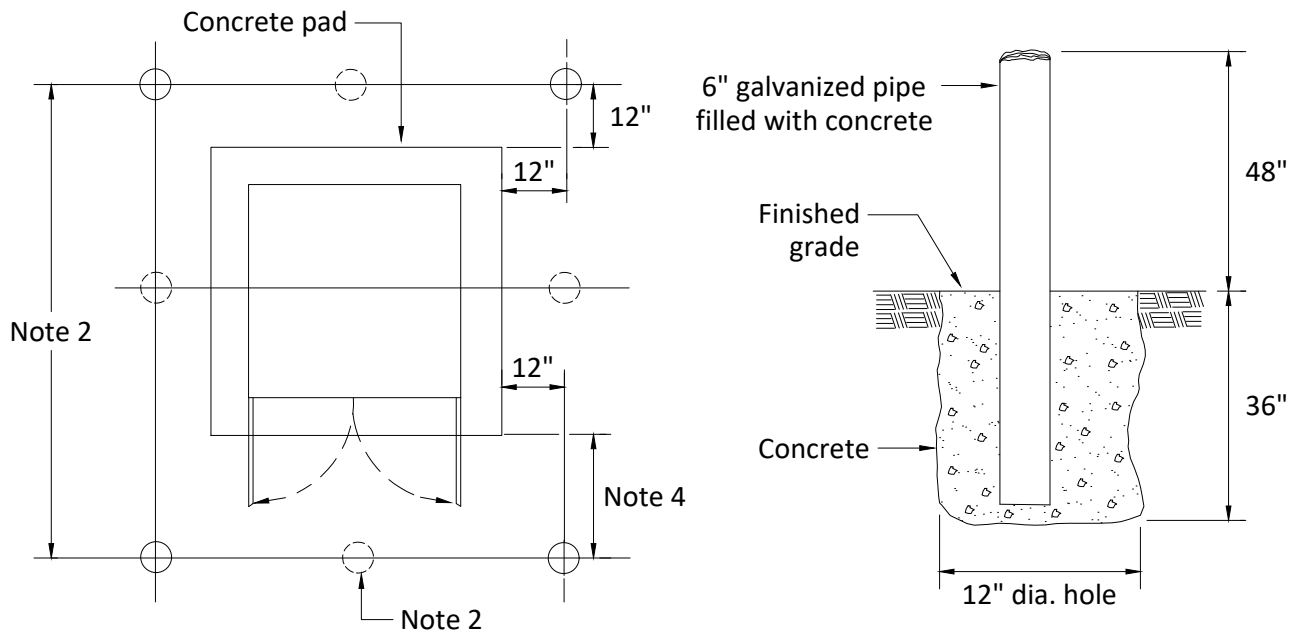

**Notes:**

1. Install guard post where protection from damage due to vehicular traffic is needed.
2. Distance between posts should not exceed 4'. Add additional posts where necessary to meet this condition. Verify location of post in front of transformer to allow for door opening (or removable post can be installed to achieve clearance).
3. This distance to be large enough to allow full opening of all equipment door(s). Contact company representative to verify dimension.
4. Paint each post "Safety Yellow" after installation for better visibility.



**GUARD POST INSTALLATION**

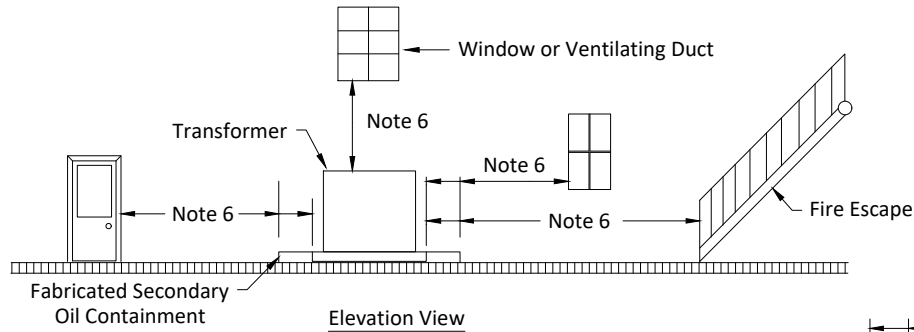
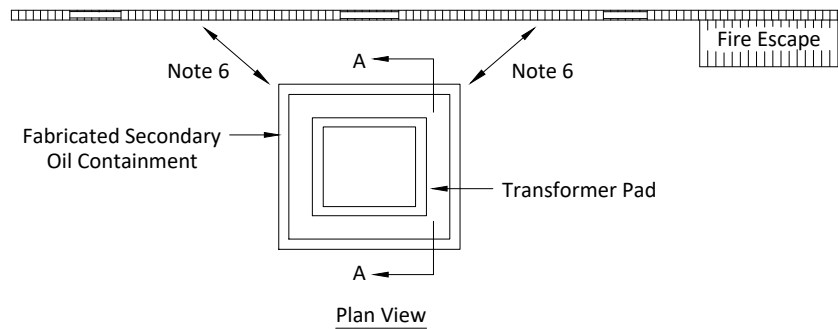

Transf. Type	Building Construction		Windows, Doors and Vents	Fire Escapes
	Fire Resistive Note 5	Non-Fire Resistive		
1 Phase	5'-0"	10'-0"	10'-0"	20'-0"
3 Phase	5'-0"	15'-0"	15'-0"	20'-0"

Clearance Table

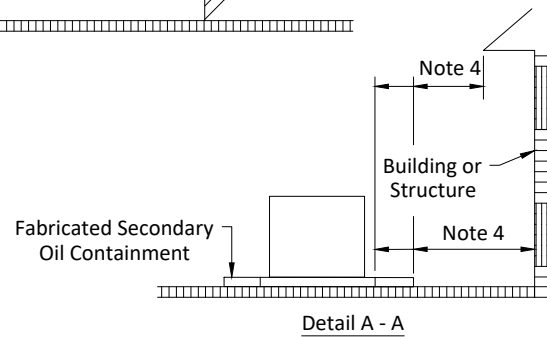

Notes:

1. All clearances shall comply with the clearance table. All dimensions specified are minimal dimensions.
2. Oncor facilities shall not be installed over underground parking garages or similar building structures, located 10' or less below ground level, unless the Oncor facilities are installed in an Oncor approved vault.
3. Oncor facilities shall not be installed under any building extents (eaves, overhangs, balconies, etc) unless the Oncor facilities are installed in an Oncor approved vault.
4. If the building has an extent, the building's reference point for measuring clearances is based on the height of the extent. Where the extent is 35' or more above ground level, clearances shall be measured horizontally from the building wall to the edge of the equipment pad or oil containment, if used. Where the extent is less than 35' above ground level, clearances shall be measured horizontally from the building extent's drip-line to the edge of the equipment pad or oil containment, if used.
5. To meet the fire-resistant dimensions, all material including building extents must meet a minimum 2-hour fire rating. Exception, if the extent is located 35' or more above ground level, only the wall is required to meet the 2-hour fire rating.
6. Clearance to building doors, windows, vents and fire escapes shall be measured radially from closest point of the Oncor equipment or oil containment, if used.
7. If hot stick use is required on operating side of pad mounted equipment, a 10' minimum clearance shall be maintained.
8. There should not be any ground level obstructions, such as, but not limited to, dedicated parking places, shrubs, cooling towers, gas meters, fencing, etc. within 10' of the operating side of the equipment or 5' from the non-operating side of the equipment.
9. Liquid flow in the immediate area surrounding Oncor transformers should be away from buildings. Where the ground is flat or slopes toward buildings, a fabricated secondary oil containment sufficient to contain all transformer oil for transformers 500 kVA and larger shall be provided.
10. There shall not be any piping or conduit under the pad, except mutually agreed upon communication conduits entering the transformer.



**CLEARANCES OF  
PAD MOUNTED TRANSFORMERS  
FROM BUILDINGS**

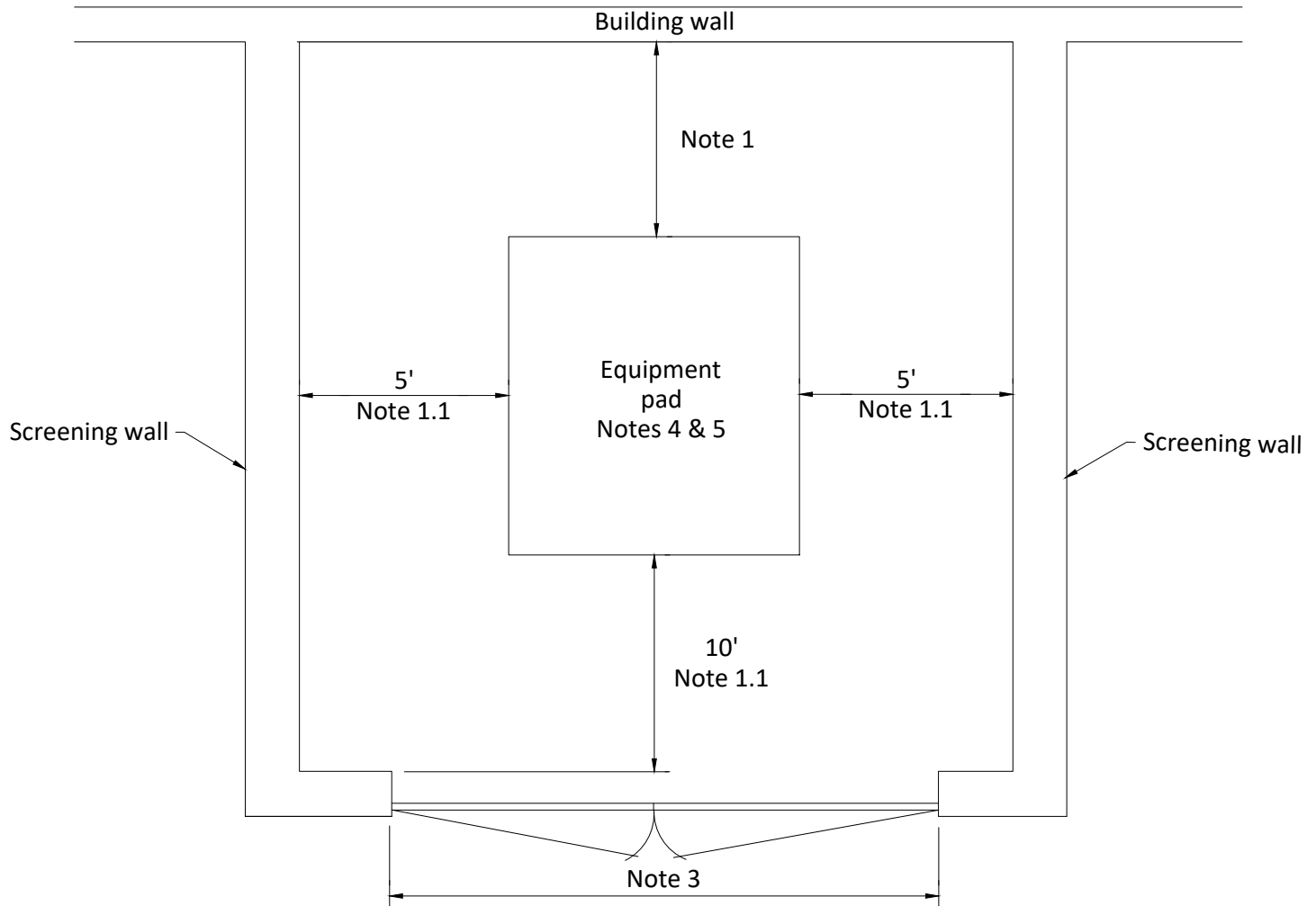

**Notes:**

1. Clearances to building walls shall be the greater of:
  - 1.1. Clearances listed in detail sheet 23 for oil filled equipment,
  - 1.2. 10' if hot stick use is required on this side of equipment, or
  - 1.3. 5' if hot stick use is not required on this side of equipment.
2. A minimum of 5' clearance is allowed if "hot stick" is not required.
3. Gate shall open outward and the width shall be no less than 10'.
4. Where ground is flat or slopes toward building, a dike sufficient to contain all oil for transformers 500 kVa and larger shall be provided. Reference detail sheet 23.
5. When transformers are installed, screening walls shall provide adequate ventilation.



**CLEARANCES AROUND  
PAD MOUNTED EQUIPMENT**

**DDS-3 UG DETAIL SHEET 24 OF 32**



## Transformer Clearance Details

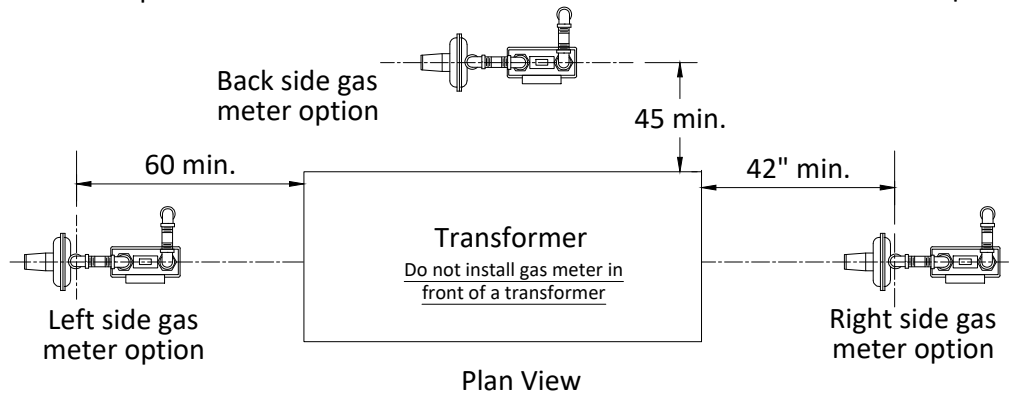
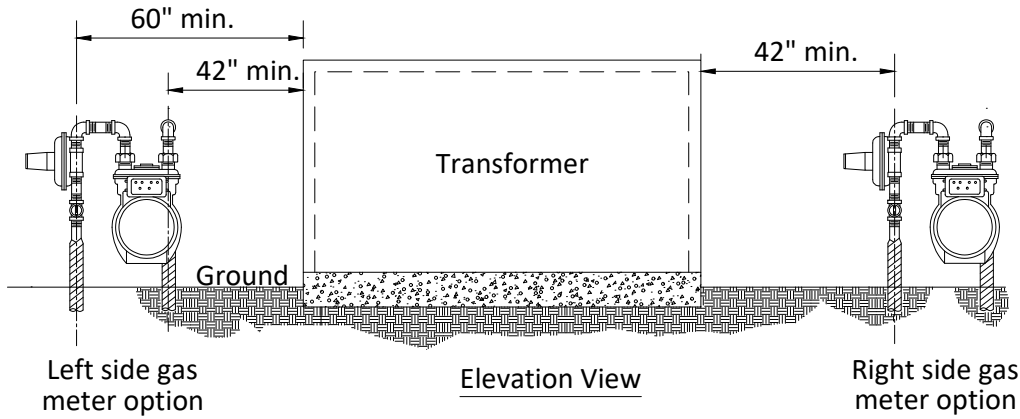

## Pedestal Clearance Details

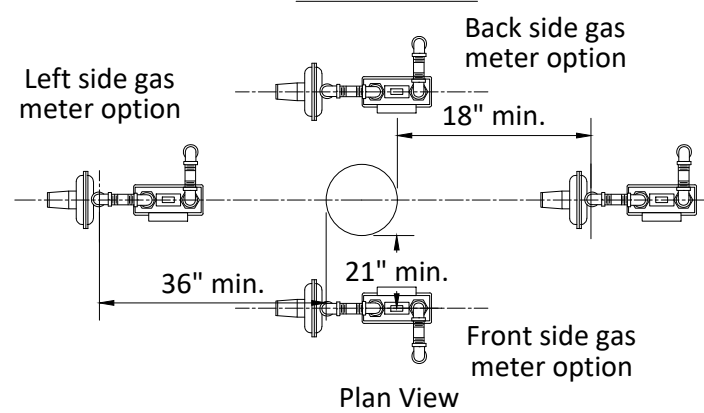
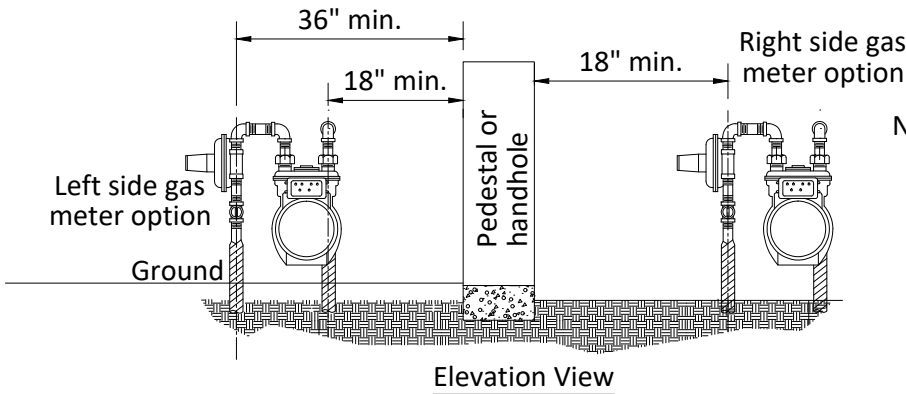

### Notes:

1. Measurements are referenced from the inlet gas riser.
2. The measurements will ensure:
  - 2.1. That a minimum clearance of 36" is attained between the entire gas meter installation and the transformer and
  - 2.2. That a minimum clearance of 12" is attained between the entire gas meter installation and all other aboveground facilities including electric and other utility pedestals and handholes.
3. This standard applies to 630 gas meter installations and smaller. For larger meter installations, contact company representative for assistance.
4. This drawing is typically used when the gas main is located in an alley or dedicated utility easement.



**ABOVEGROUND CLEARANCES  
FROM GAS METER INSTALLATIONS**

**DDS-3 UG DETAIL SHEET 25 OF 32**

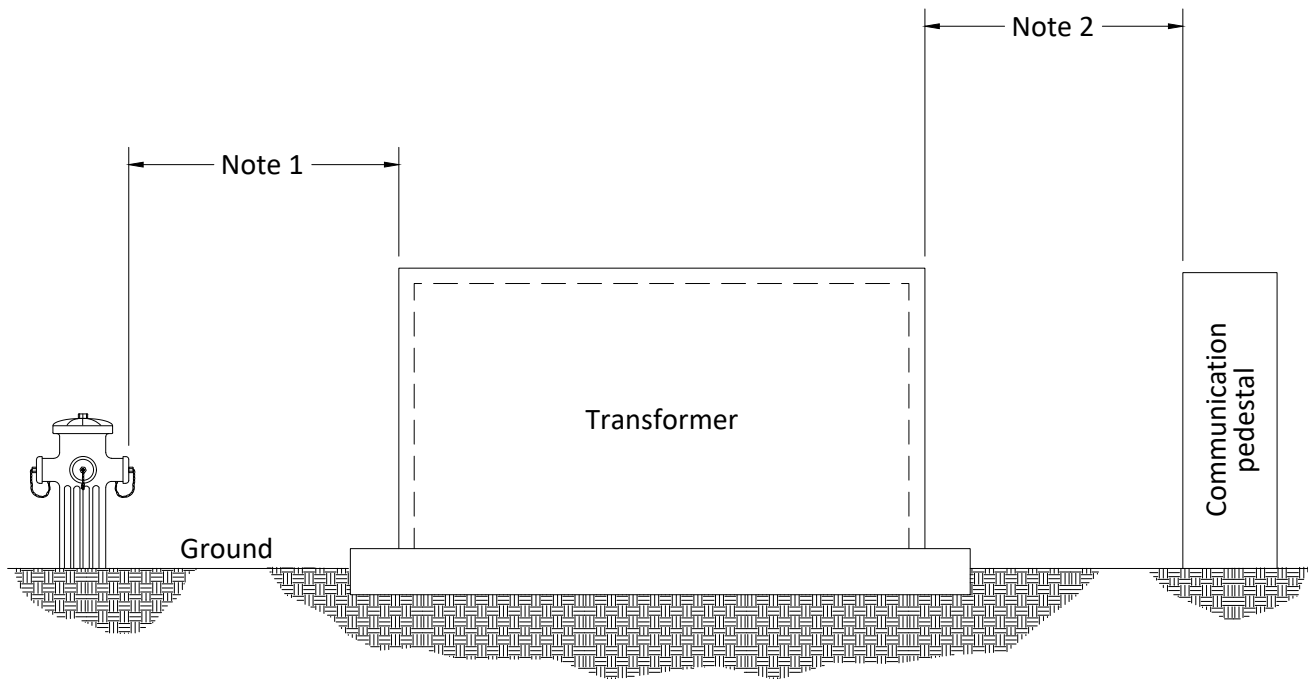

**Notes:**

1. Pad mounted equipment, pedestals and other above ground enclosures should be located not less than 4' from fire hydrants. Where conditions do not permit a clearance of 4', a clearance of not less than 3' is allowed.
2. All above ground metallic power and communication equipment (pedestals, transformer cases, apparatus cases, etc.) that are separated by a distance of 6' or less shall be bonded. Reference detail sheet 16 for method for providing utility company equipment ground.



**CLEARANCES OF ABOVEGROUND  
EQUIPMENT - FOREIGN UTILITIES  
ENCLOSURES AND EQUIPMENT**

**DDS-3 UG DETAIL SHEET 26 OF 32**

# CLEARANCES OF SWIMMING POOLS FROM OVERHEAD FACILITIES

## FIGURE 2-B

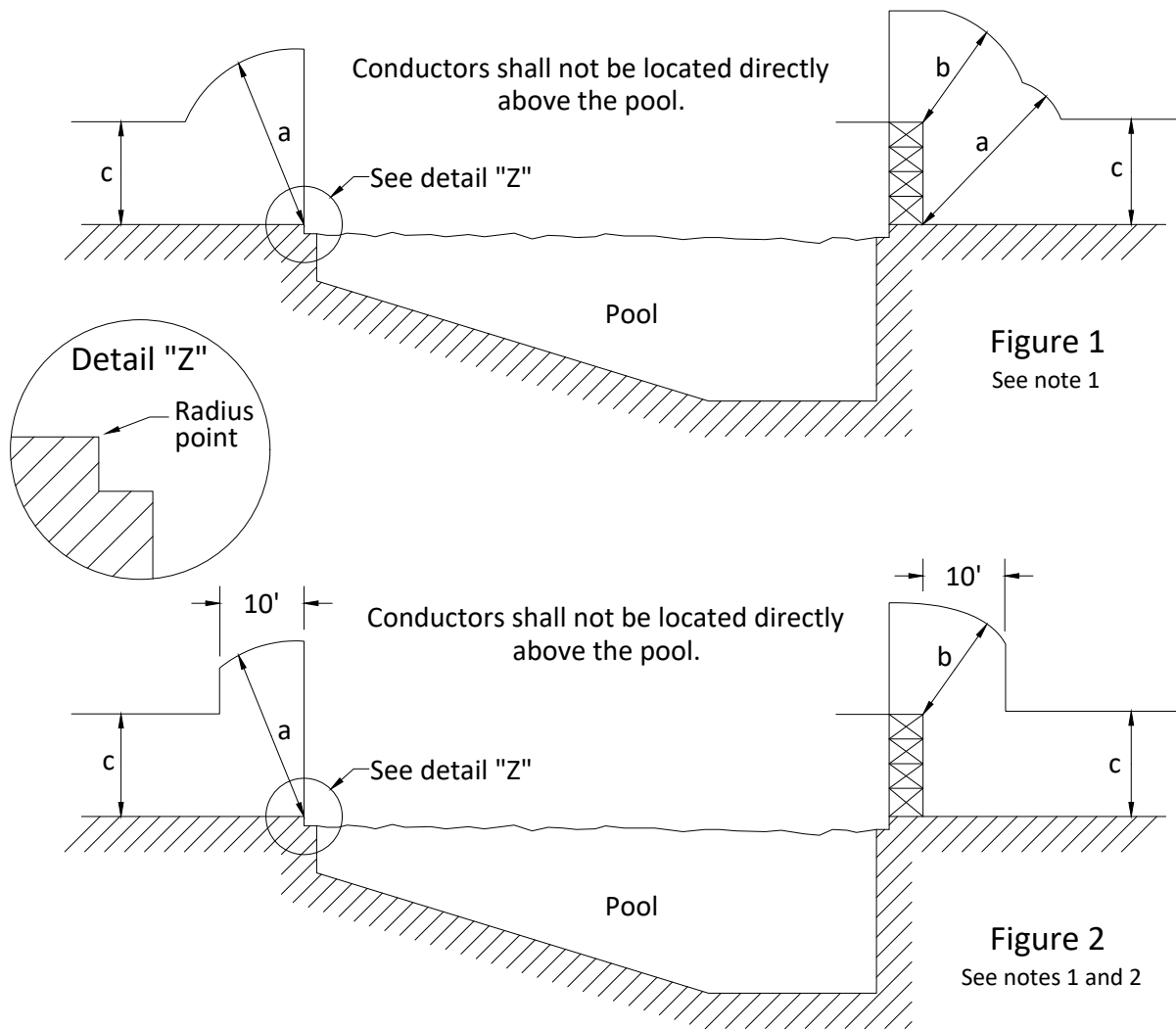

**Notes:**

1. Dimensions for "a", "b", and "c" shown above are defined by table on Page 18.
2. Figure 2 shall be applied ONLY to:
  - Overhead Guys;
  - Neutral Conductor;
  - Cabled Conductor  $\leq 750$  V Phase to Ground



**LOCATION OF SERVICE LATERAL  
NEAR A SWIMMING POOL**

**DDS-3 UG DETAIL SHEET 27 OF 32**

# CLEARANCES OF SWIMMING POOLS FROM OVERHEAD FACILITIES (cont'd)

## FIGURE 2-B

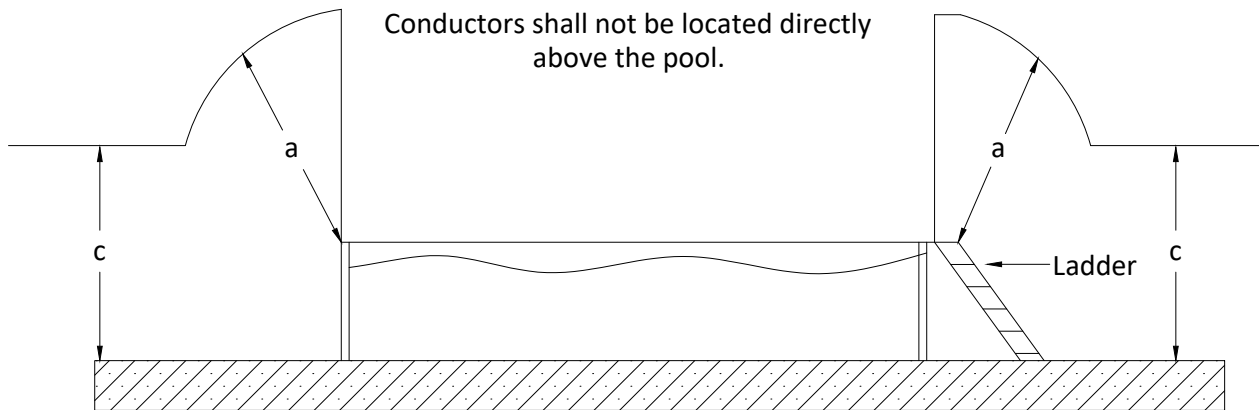

Above ground swimming pool without a deck. Clearances maintained from the highest point of the installation.

**Figure 3**  
See notes 1 and 3

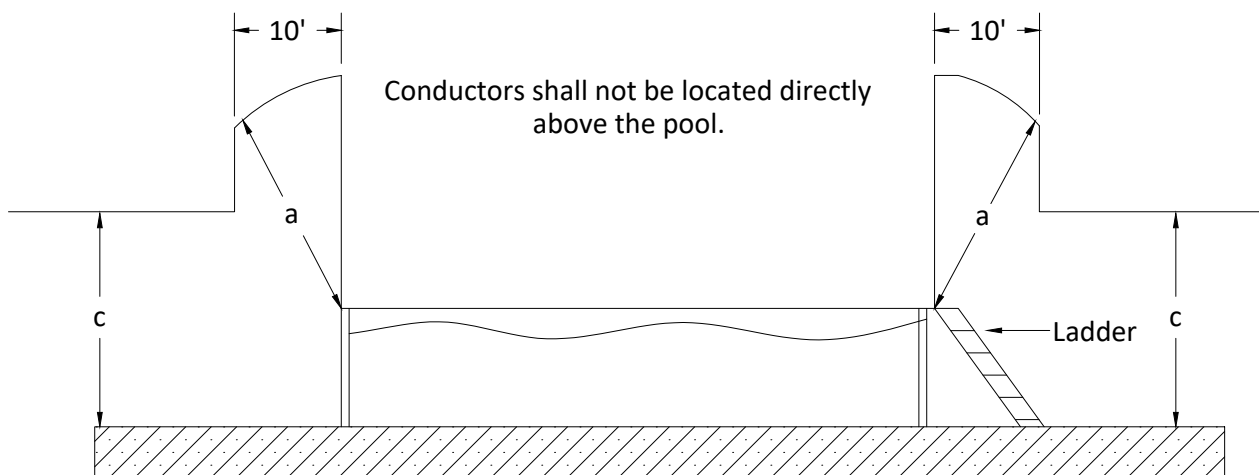

Above ground swimming pool without a deck. Clearances maintained from the highest point of the installation.

**Figure 4**  
See notes 1, 2, and 3

**Notes:**

1. Dimensions for "a" and "c" shown above are defined by table on Page 18.
2. Figure 4 shall be applied ONLY to:
  - Overhead Guys;
  - Neutral Conductor;
  - Cabled Conductor  $\leq 750$  V Phase to Ground
3. Proper respective clearances must be maintained if a diving platform, tower, water slide, or other fixed, pool-related structure exists.



**LOCATION OF SERVICE LATERAL  
NEAR A SWIMMING POOL  
(CONT.)**

**DDS-3 UG DETAIL SHEET 28 OF 32**

## CLEARANCES OF SWIMMING POOLS FROM OVERHEAD FACILITIES (cont'd)

### TABLE 2-B

The table below contains clearance values based upon the requirements of the National Electrical Safety Code with allowances for worst case conditions. Actual clearance requirements vary with conductor size and type, ambient air temperature, and other factors. The values shown in the table are meant to be a guideline. **When clearances are less than indicated in the table, the Customer should contact Company for exact requirements based on field conditions.**

Please Note: **Wires, conductors, cables, or unguarded rigid live parts shall not pass over a swimming pool.**

	Requirements	Overhead Guy or Neutral (ft)	Bundled or Cabled Secondary or Service (ft)	Open Wire Secondary or Service (ft)	Pole Line or Primary Conductor (ft)
a.	Clearance in any direction from water level, edge of pool, base of diving platform, or anchored raft.	27	27.5	28	30
b.	Clearance in any direction to diving platform, tower, water slide or other fixed, pool related structure.	19	19.5	20	22
c.	Vertical clearance over adjacent land which is driveways, parking lots, and alleys subject to truck traffic (any vehicle exceeding 8' in height).	20.5	21	21.5	23.5
d.	Vertical clearance over adjacent land which is spaces and ways subject to pedestrians or restricted traffic only. *	14.5	17	17.5	19.5
e.	These clearances do not apply to overhead guys, neutral conductors and cabled conductor $\leq$ 750 volts when these facilities are 10' or more horizontally from the edge of the pool, diving platform, diving tower, water slide, or other fixed, pool related structure.	10	-	-	-



**LOCATION OF SERVICE LATERAL  
NEAR A SWIMMING POOL  
(CONT.)**

**DDS-3 UG DETAIL SHEET 29 OF 32**

# CLEARANCE OF SWIMMING POOLS FROM UNDERGROUND FACILITIES

FIGURE 2-C

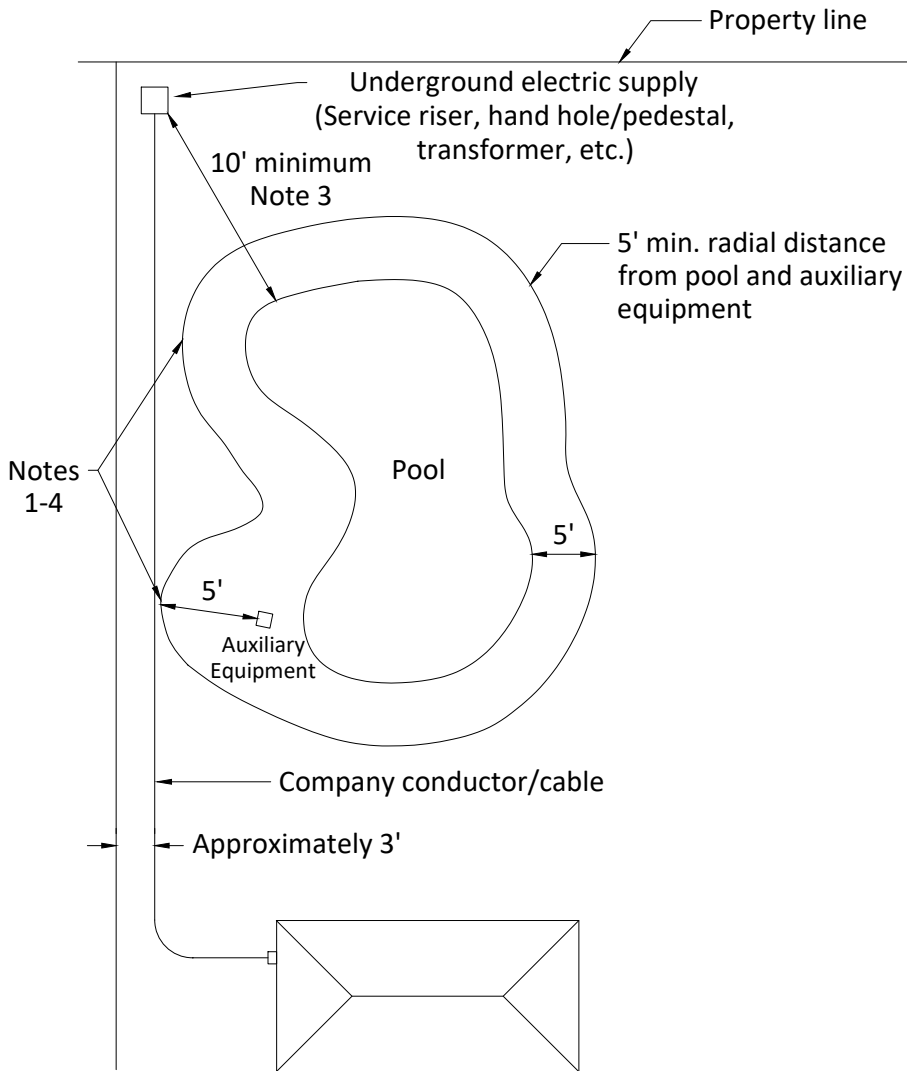

Notes:

1. Company Conductor/Cable - Oncor Electric Delivery Company LLC and its officers, agents, employees, successors, and assigned owned cable and/or conductor. (i.e. primary, secondary, service lateral)
2. A swimming pool or its auxiliary equipment or water pipes shall not be installed within 5' of direct-buried company conductor/cable.
3. Where a swimming pool must be installed within 5' of an existing direct-buried primary, secondary, and/or service, the primary, secondary, and/or service shall be installed in a continuous conduit to the point of delivery (POD).
4. Conduits installed for company conductor/cable shall be a minimum of 2' from the water's edge of the swimming pool. This distance applies to new pool site conduits and to the re-routing of existing company primary, secondary, and/or service.
5. The swimming pool auxiliary equipment conduits, conductors, water pipes, or customer owned facilities may not be installed in the same trench as the company conductor/cable.
6. Pad mounted equipment shall be located 10' or more from the water's edge.
7. Local requirements may require greater clearances.
8. For additional information related to company conductor/cable and swimming pools see document DDS1PR at Oncor.com.
9. Allowing pools and pool equipment as close as 2' from Oncor owned medium voltage cables (5 through 25 kV) may require the Oncor R.O.W. Department involvement.



**LOCATION OF SERVICE LATERAL  
NEAR A SWIMMING POOL  
(CONT.)**

**DDS-3 UG DETAIL SHEET 30 OF 32**

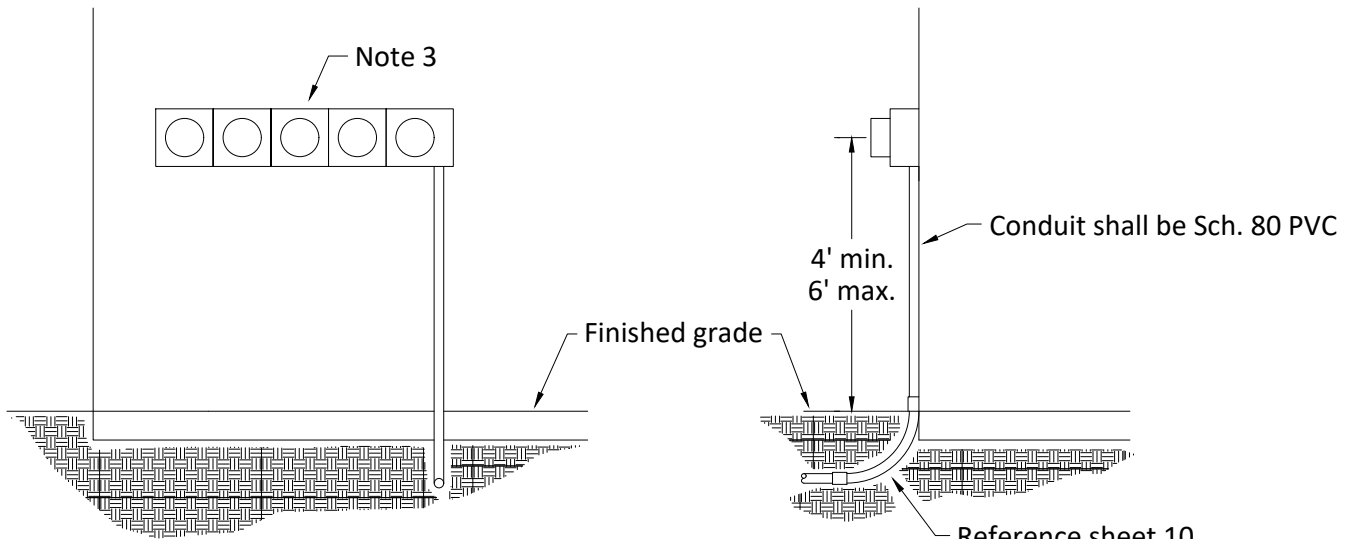

Typical Gang Meter Installation  
without Service Enclosure

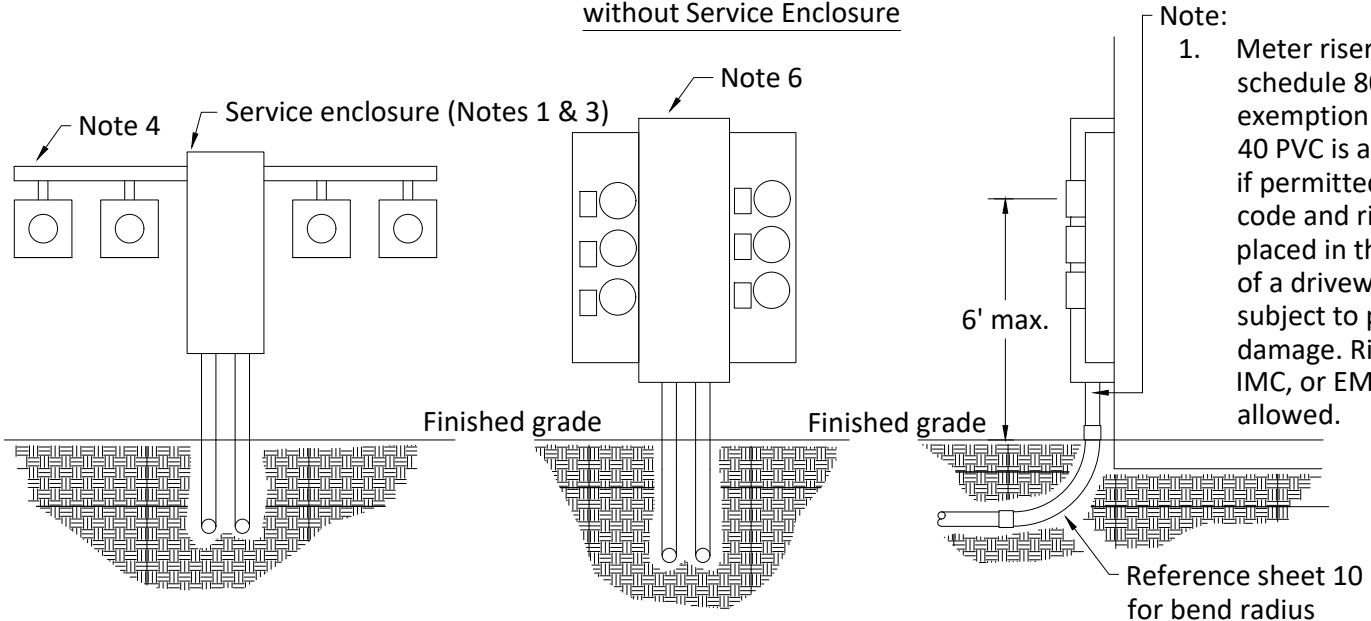

Typical Gang Meter  
with Service Enclosure

Typical Meter Pack

Note:  
1. Meter riser shall be schedule 80 PVC. exemption: schedule 40 PVC is acceptable if permitted by local code and riser is not placed in the vicinity of a driveway or subject to physical damage. Rigid steel, IMC, or EMC is not allowed.

**Notes:**

1. Service entrance enclosure (for multiple meter installations) provided by company and installed by contractor. Contact company representative for information.
2. Meter sockets provided and installed by contractor.
3. Reference Oncor's "Electric Service Guidelines" for meter and service enclosure information.
4. Conductors, raceway and gutter provided and installed by contractor.
5. Service entrance conductors to be continuous from meter socket into service enclosure.
6. Contact company for approval of meter packs prior to letting bids and installing equipment.



**TYPICAL APARTMENT METER  
INSTALLATIONS**

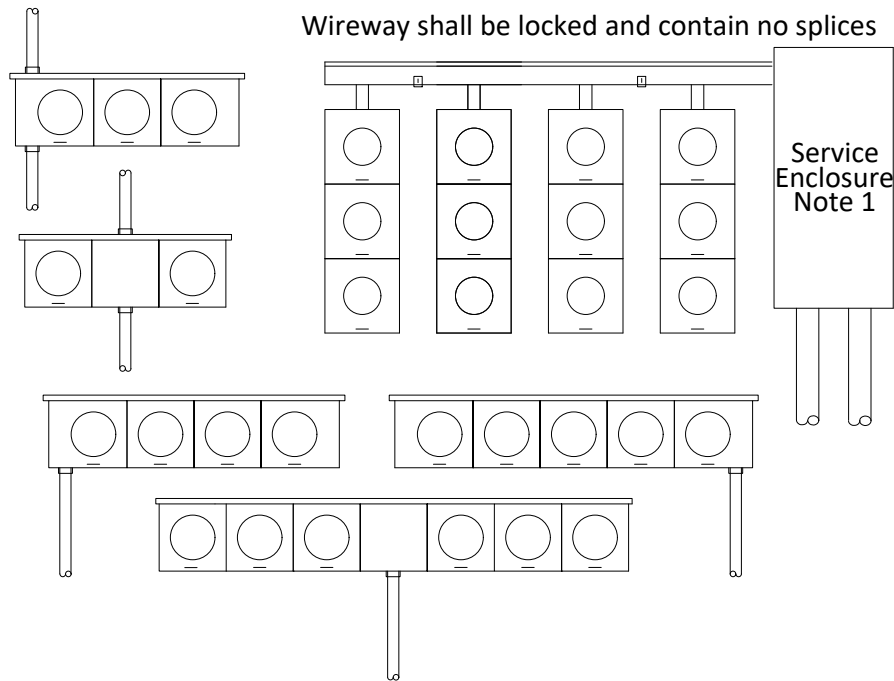

Typical Gang Meter Installations      Note 6

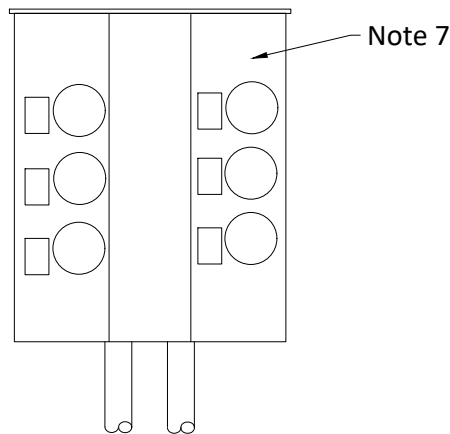

Typical Meter Pack Installation

**Notes:**

1. Service entrance enclosure (when required for multiple meter installations) provided by company and installed by contractor. Contact company representative for information.
2. Meter sockets provided and installed by contractor.
3. Reference Oncor's "Electric Service Guidelines" for meter and service enclosure information.
4. Conductors, raceway and gutter provided and installed by contractor.
5. Service entrance conductors to be continuous from meter socket into service enclosure.
6. Each socket must be clearly and permanently marked on the interior and exterior of the meter socket to indicate each apartment or location served.
7. Contact company for approval of meter packs prior to letting bids and installing equipment.
8. Contact company for approval of layouts other than those shown above prior to letting bids and installing equipment.



**METER SOCKETS  
TYPICAL LAYOUTS**