



Specification for Electrical Service Lateral Raceways- Single Unit & Duplex Residential

Specification DDS-1
Revision 13, January 2018

**Oncor Electric Delivery Company
Specifications for Electrical Service Lateral Raceways
Single Unit & Duplex Residential
Specification Number DDS-1**

Table of Contents

Section 1- Scope	Page 2
Section 2- References	Page 2
Section 3- Definitions	Page 2
Section 4- General	Page 2
Section 5- Company responsibility	Page 3
Section 6- Contractor responsibility	Page 3
Section 7- Acceptance	Page 4

ATTACHMENTS:

DDS-1 Detail Sheets 1 – 17

**Oncor Electric Delivery Company
Specifications for Electrical Service Lateral Raceways
Single Unit & Duplex Residential
Specification Number DDS-1**

1. SCOPE

This document represents the minimum requirements and specifications for the installation of electrical service lateral raceways, serving single unit and duplex residences, to be transferred to Oncor Electric Delivery Company ownership.

2. REFERENCES

This specification shall be used in conjunction with the latest revision of the following publications.

2.1 Electric Service Guidelines, Oncor Electric Delivery Company.

3. DEFINITIONS

3.1 Company: Oncor Electric Delivery Company and its designated representatives.

3.2 Contractor: Individual or firm installing underground electrical service lateral raceway.

3.3 Authority Having Jurisdiction: Generally an incorporated City or Town, but may include an agency of the County, State or Federal Government.

3.4 Point of Delivery: The point where Company's conductors are connected to the premise's service conductors, typically at the meter socket.

4. GENERAL

4.1 The latest edition of all applicable building and safety codes shall be followed in the installation of the electrical service lateral raceway. Included, but not limited to, are the:

4.1.1 Local City Building Code

4.1.2 National Electrical Safety Code (NESC)

4. GENERAL (continued)

4.1.3 U. S. Occupational Safety and Health Act of 1970 (OSHA)

4.1.4 Local City Location and Coordination Policy (if applicable)

4.2 Prior to construction a meeting shall be held to discuss and coordinate construction and inspection.

4.3 No electrical facilities shall be connected by the Company until after the final inspection is made and approval by the Authority Having Jurisdiction, as required by code, has been received.

5. COMPANY RESPONSIBILITY- The following shall be performed by, and the responsibility of, the Company:

5.1 The Company inspector is to check all conduit installations prior to backfilling.

5.2 After approval of the installed conduit system by the Company inspector, and after all appropriate contracts, agreements, and easements have been signed and any CIAC (contribution in aid of construction) has been paid, the Company shall install service lateral cables up to the line side of the point of delivery.

5.3 Upon notification of final electrical inspection from the Authority Having Jurisdiction, the Company is to make final electrical connections at the line side of the point of delivery.

6. CONTRACTOR RESPONSIBILITY- The following shall be performed by, and the responsibility of, the Contractor:

6.1 The Contractor is to coordinate with the Company inspector for inspection of work prior to backfilling.

6.2 The Contractor is to replace at his expense any damaged equipment or correct any work not in compliance with the requirements in these specifications, the project sketch, the DDS-1 Detail Sheets or as specified by the Company.

6.3 The Contractor is to furnish all conduit, bends, equipment and labor to install the service lateral raceway as per the DDS-1 Detail Sheets. All conduit and bends shall be Schedule 40 PVC or Schedule 80 PVC and shall be electrical grade. All PVC conduit and bends shall be gray in color.

6. CONTRACTOR RESPONSIBILITY (continued)

6.4 Contractor is to provide and install an oversized PVC conduit/raceway fitting that slips over the service lateral conduit. This fitting prevents exposure of conductors due to the conduit/raceway movement due to soil expansion and contraction. Conduit inserted a minimum of 12” into the fitting. Approved PVC conduit/raceway fitting manufacturers and part numbers:

Conduit Size	MFR	MRF#
2”	Carlon	E957JXX
2”	Cantex	5144028
2”	Heritage	610407
3”	Carlon	E954LXX
3”	Cantex	5144043
3”	Heritage	610409
4”	Carlon	E954NXX
4”	Cantex	5144027
4”	Heritage	610410

6.5 Contractor is to pull a mandrel through each conduit to check and clear blockage and leave an approved pull tape in each conduit. Pull tape shall be furnished by the party providing conduit and shall be installed by Contractor. Mandrel shall be furnished by Contractor. Conduit shall be plugged at both ends. Reference DDS-1 Detail Sheet 10 for approved pull tapes.

6.6 The Contractor is to secure inspection and approval of the premise’s facilities by the Authority Having Jurisdiction prior to connection of electrical facilities.

6.7 The Contractor shall provide and install self- contained meter sockets. Reference the Electrical Service Guidelines for approved self- contained meter sockets.

6.8 The Contractor is to make all connections on the load side of the point of delivery.

7. ACCEPTANCE

7.1 The Company inspector shall meet with the Contractor and review the project prior to acceptance. Electrical facilities will be installed only after acceptance of the service lateral raceway by the Company inspector.

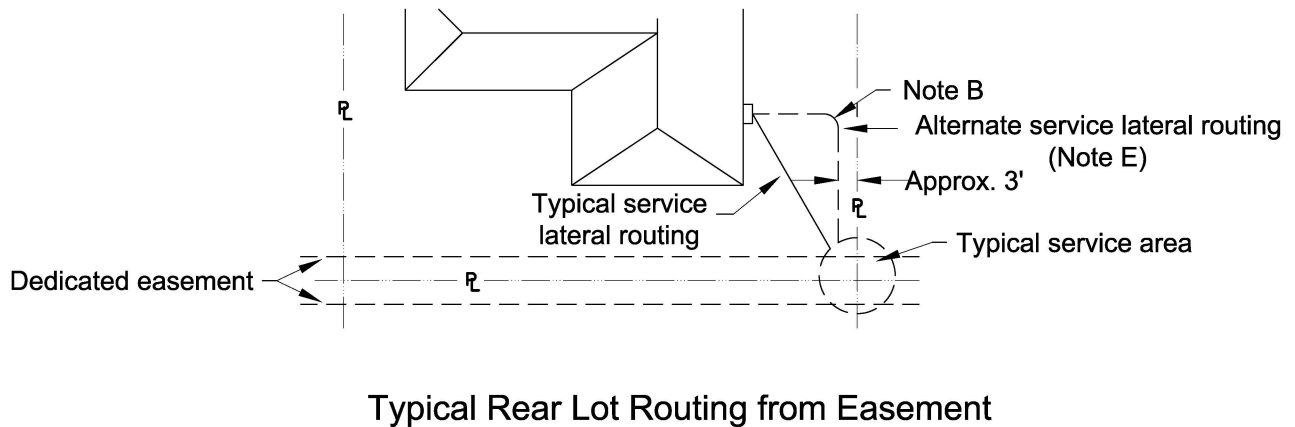
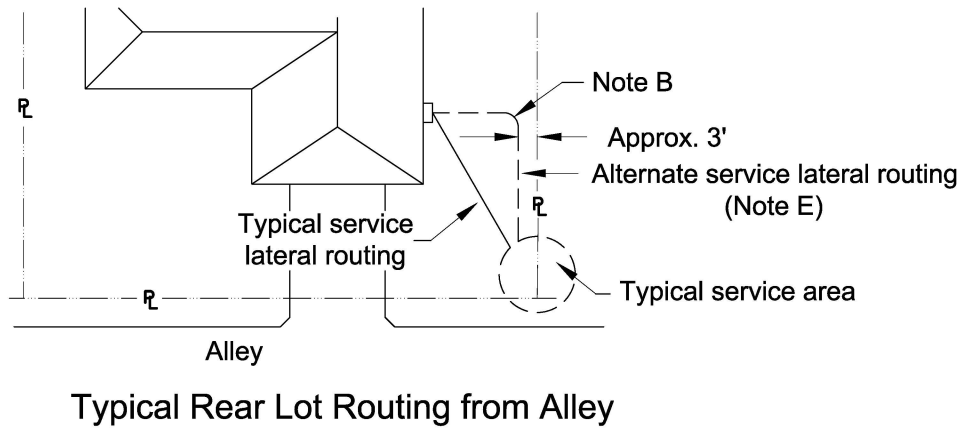
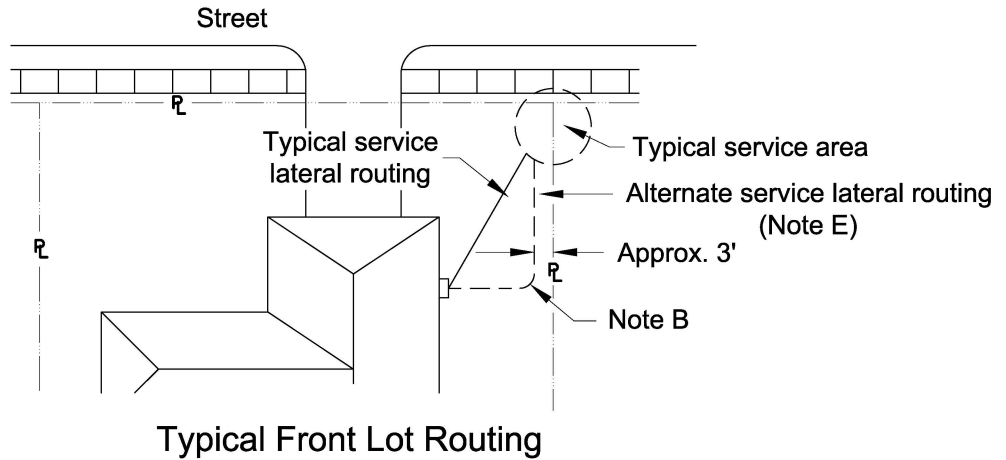

Notes:

- A. Consult company representative for size of conduit to be installed.
- B. Reference detail sheet 12 for bend radius for all horizontal and vertical conduit bends.
- C. Limit raceway to three 90° bends. If more than three 90° bends are required, contact company representative.
- D. Distance between 90° bends shall be five feet minimum.
- E. Alternate routing to allow for swimming pools and other obstructions. Reference dds-1 detail sheet 16.



**Service Lateral Routing -
Single Family Residential**

DDS-1 Detail Sheet 1 of 17

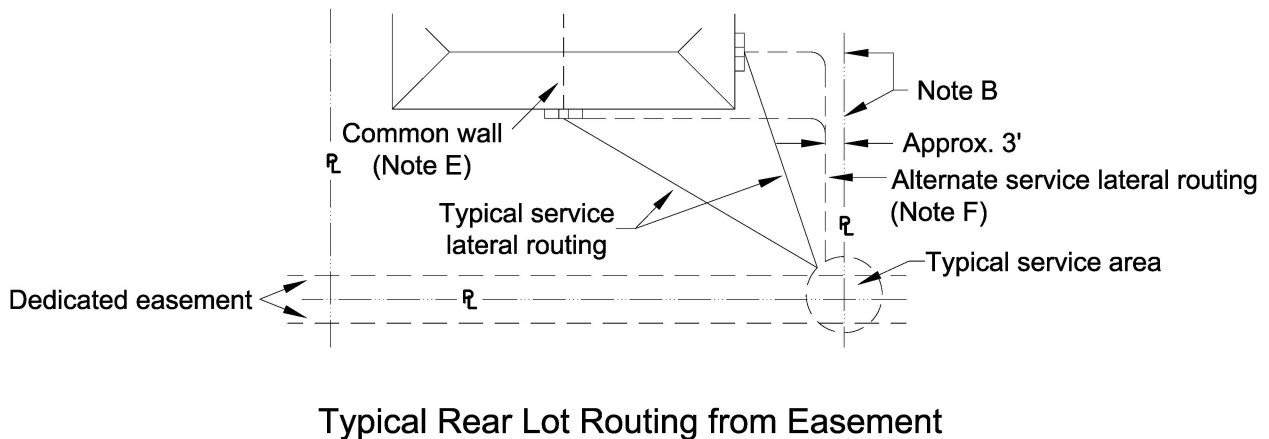
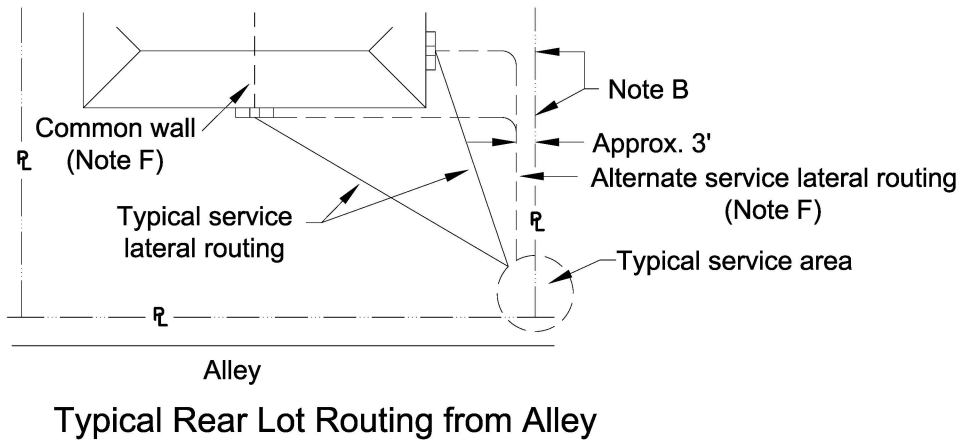
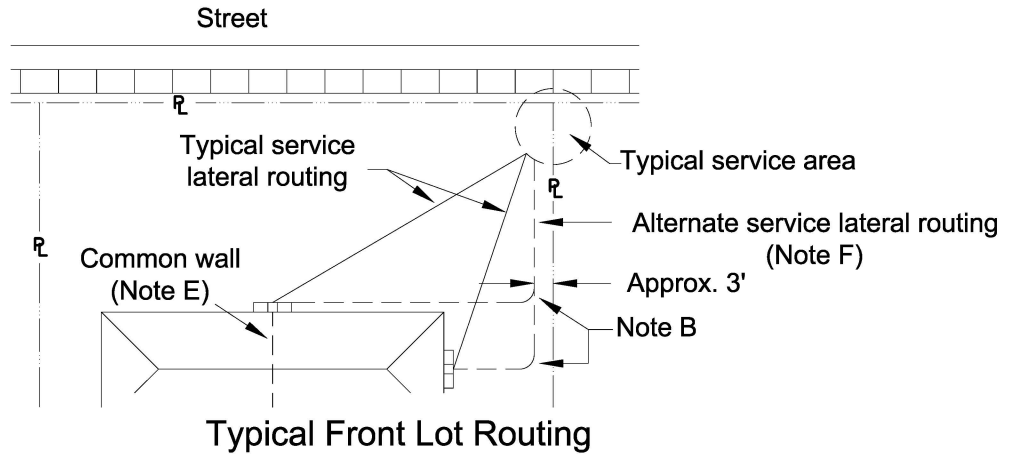

Notes:

- A. Consult company representative for size of conduit to be installed.
- B. Reference detail sheet 12 for bend radius for all horizontal and vertical conduit bends.
- C. Limit raceway to three 90° bends. If more than three 90° bends are required, contact company representative.
- D. Distance between 90° bends shall be five feet minimum.
- E. For a one owner two unit living structure, company provides one point of delivery to common wall.
- F. Alternate routing to allow for swimming pools and other obstructions. Reference DDS-1 detail sheet 16.



**Typical Service Lateral
Routing - Residential Duplex**

DDS-1 Detail Sheet 2 of 17

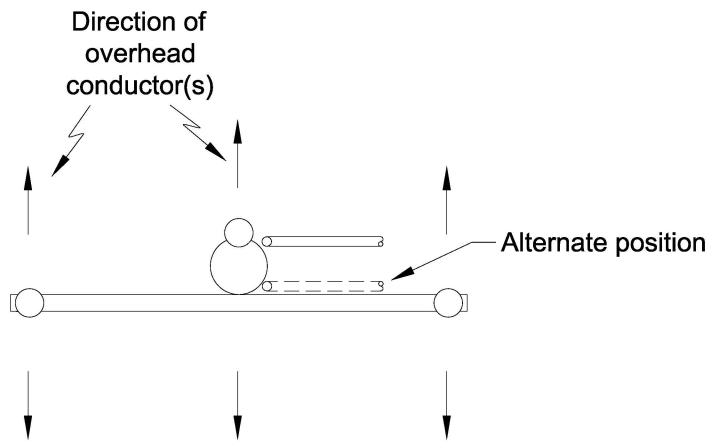

Top View

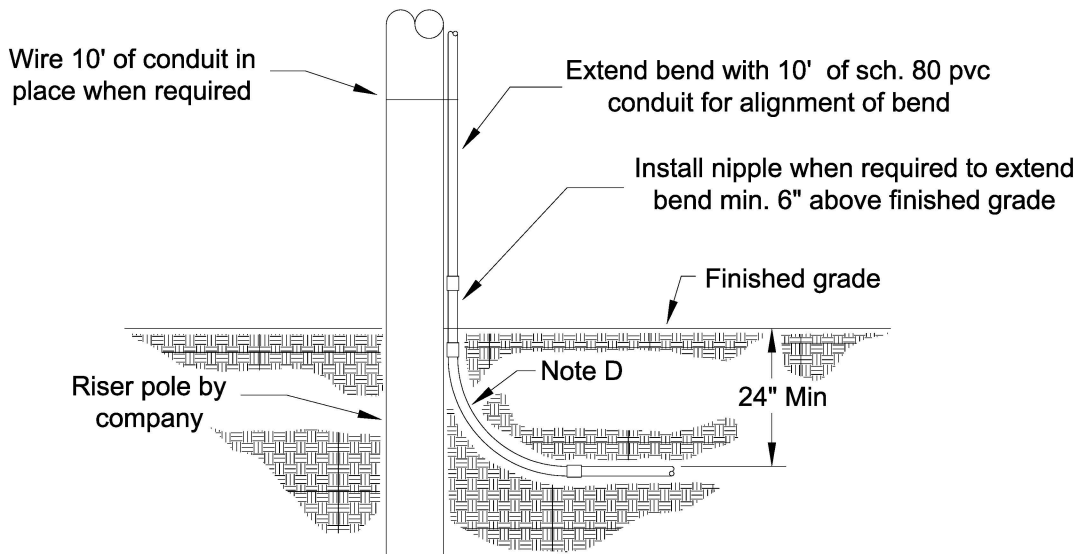

Plan View

Notes:

- A. Contact company representative for (1) routing of conduit line, (2) size of conduit, and (3) installations requiring more than one riser on pole.
- B. Limit raceway to three 90° bends. If more than three 90° bends are required, contact company representative.
- C. Distance between 90° bends shall be five feet minimum.
- D. Reference detail sheet 12 for bend radius for all horizontal and vertical conduit bends.



**Typical Service Area-
Secondary Riser Pole**

DDS-1 Detail Sheet 3 of 17

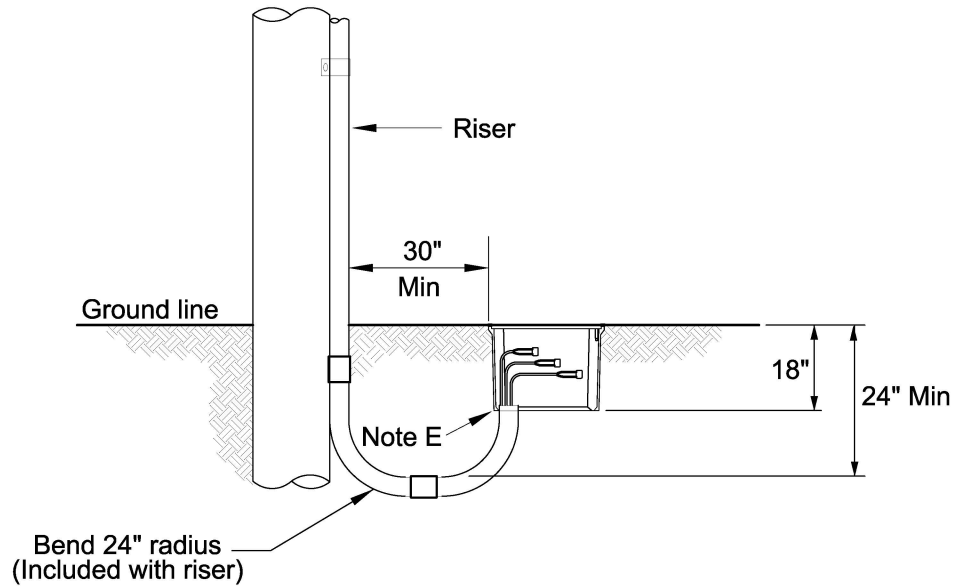
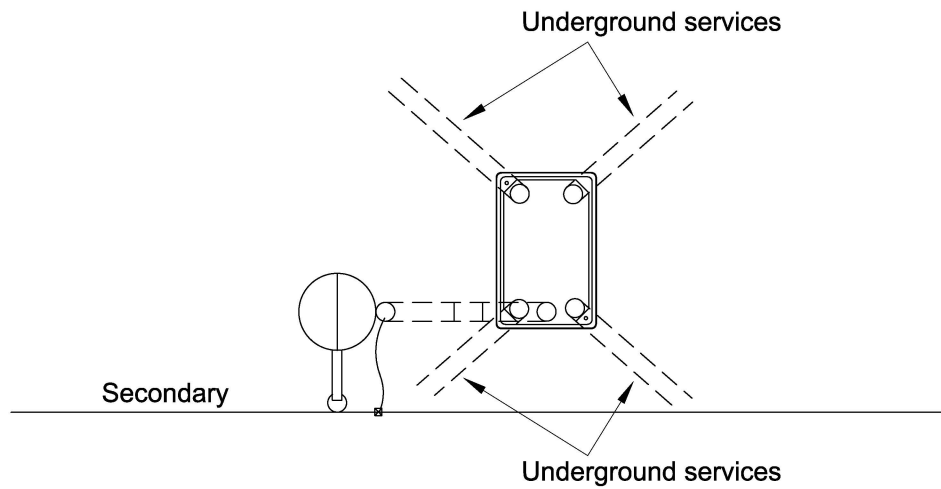

Notes:

- A. Contact company representative for (1) routing of conduit line, (2) size of conduit, and (3) installations requiring more than one riser on pole.
- B. Limit raceway to three 90° bends. If more than three 90° bends are required, contact company representative.
- C. Reference detail sheet 12 for bend radius for all horizontal and vertical conduit bends.
- D. Cut off bend flush with bottom of secondary/ service box.



Secondary Riser with Secondary Service Box, Conduit System

DDS-1 Detail Sheet 4 of 17

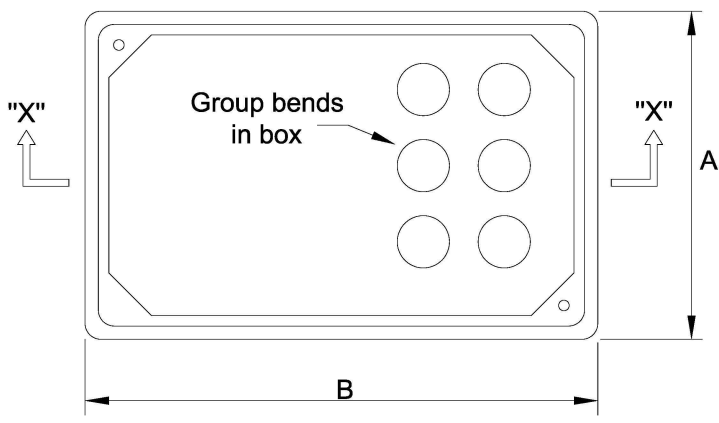

Plan View With Cover Removed

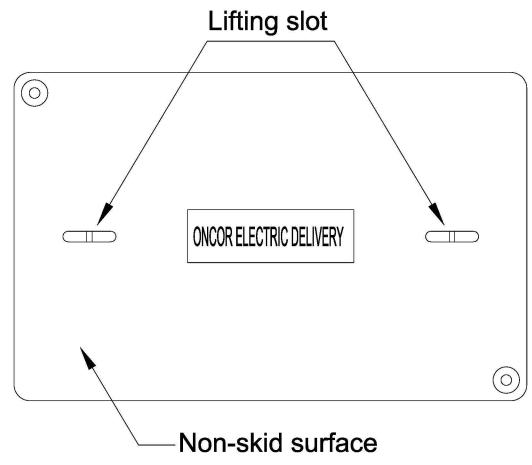

Cover - Top View

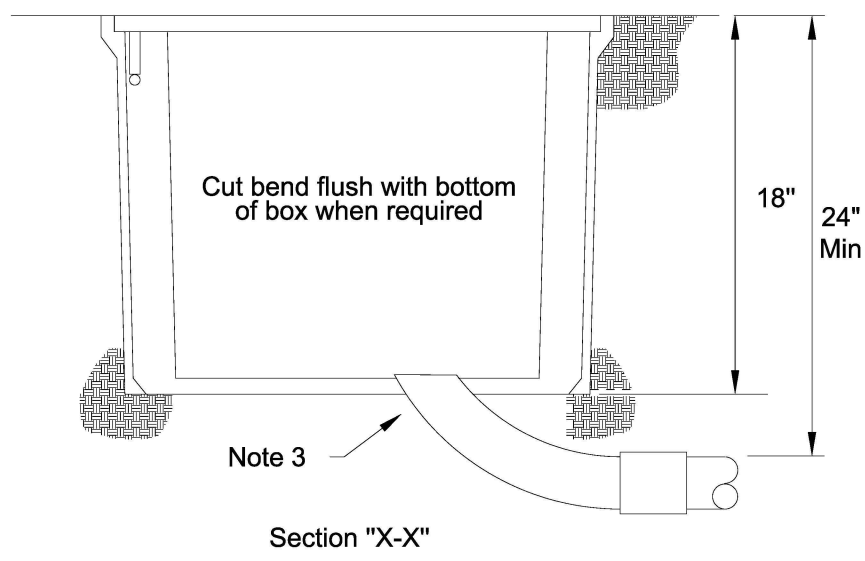

Section "X-X"

Box size (in.)	Overall dim. (in.)		Max. no. circuits
	A	B	
13 X 24	16	25	5
17 X 30	20	33	8

Box size (in.)	Replacement lid TSN
13 X 24	326506
17 X 30	326509

Notes:

1. Consult company representative for (1) approved precast secondary subsurface boxes, (2) size of conduit, and (3) routing path of conduit into secondary subsurface box.
2. For installation of conduit to in- service secondary subsurface boxes, consult company representative for details.
3. Reference detail sheet 12 for bend radius for all horizontal and vertical conduit bends.



**Typical Service Area-
Subsurface
Secondary / Service Box**
DDS-1 Detail Sheet 5 of 17

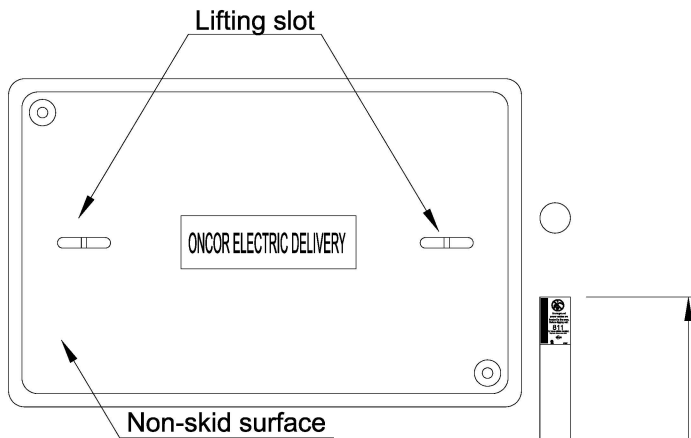

Top View

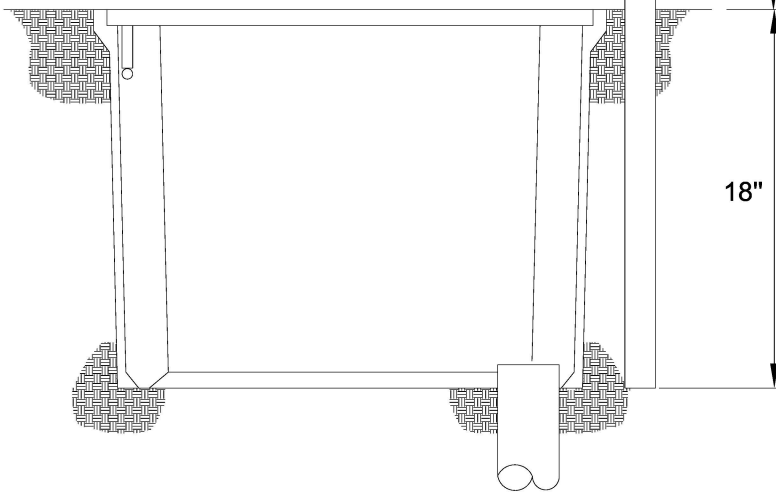

Side View

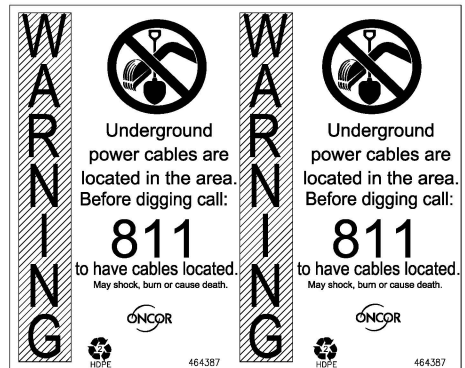

Notes:

- A. Consult company representative on where to acquire marker post.
- B. Install marker post within 3 inches of one end of subsurface box when box is being installed.
- C. Remove marker post when the last permanent meter is set.



**Marker Post for
Secondary / Service Box**

DDS-1 Detail Sheet 6 of 17

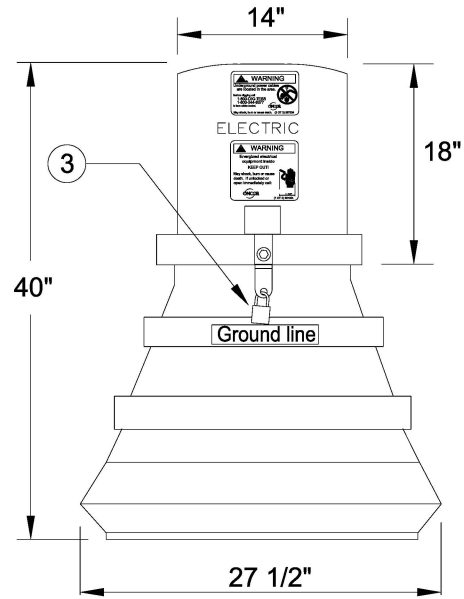
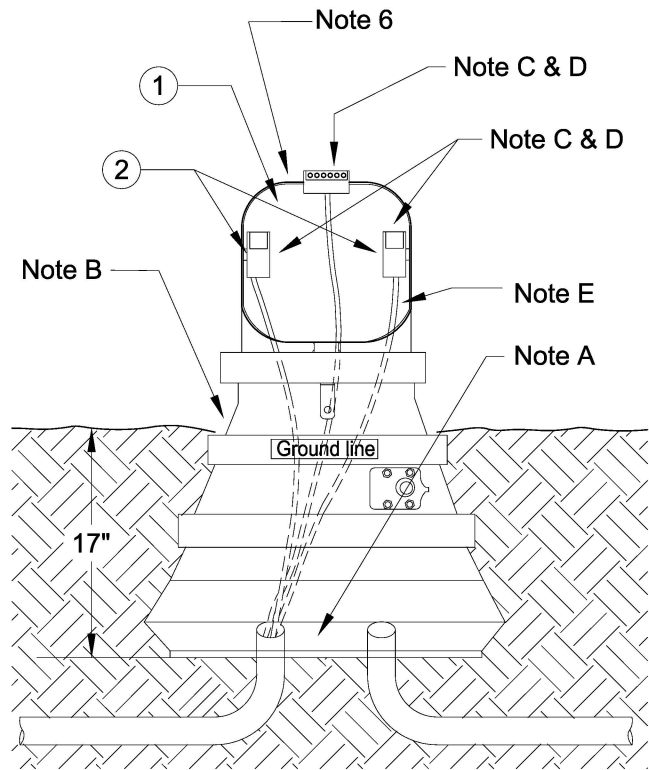

Replacement Parts	
Part	TSN.
6 Position connector #6 - 350 conductor	397461
6 Position connector #6 - 500 conductor	397463
Clear lexan connector cover	397462
Cover tie	386181

Installation notes:

- A. Center the conduits/ cables in the bottom opening of the pedestal.
- B. Bury the pedestal to the ground line marker and tamp the soil around the unit to secure it in the upright position.
- C. the connector cover is a reuseable item. If missing or damaged replace with parts as shown. All connector covers must be secured with ties. If the ties are cut or damaged in any way, replace with stock replacement parts as shown.
- D. use the center top mounted connector for the neutral conductor. Use the side mounted connectors for the "hot" conductors.
- E. Position, cut and remove cable insulation. For good set screw compression on the conductors, extend bare conductor 1/4 inch above the connector. Brush conductors to remove oxide before installing in connector and apply inhibitor.
- F. Locate pedestal to minimize chance of pedestal being struck by vehicular traffic.
- G. Consult company representative for (1) approved secondary pedestals, (2) size of conduit, and (3) routing path of conduit into secondary pedestal.
- H. For installation of conduit to in- service secondary pedestals, consult company representative for details.
- I. Reference detail sheet 12 for bend radius for all horizontal and vertical conduit bends.



**Typical Service Area-
Single Phase
Secondary Pedestal**

DDS-1 Detail Sheet 7 of 17

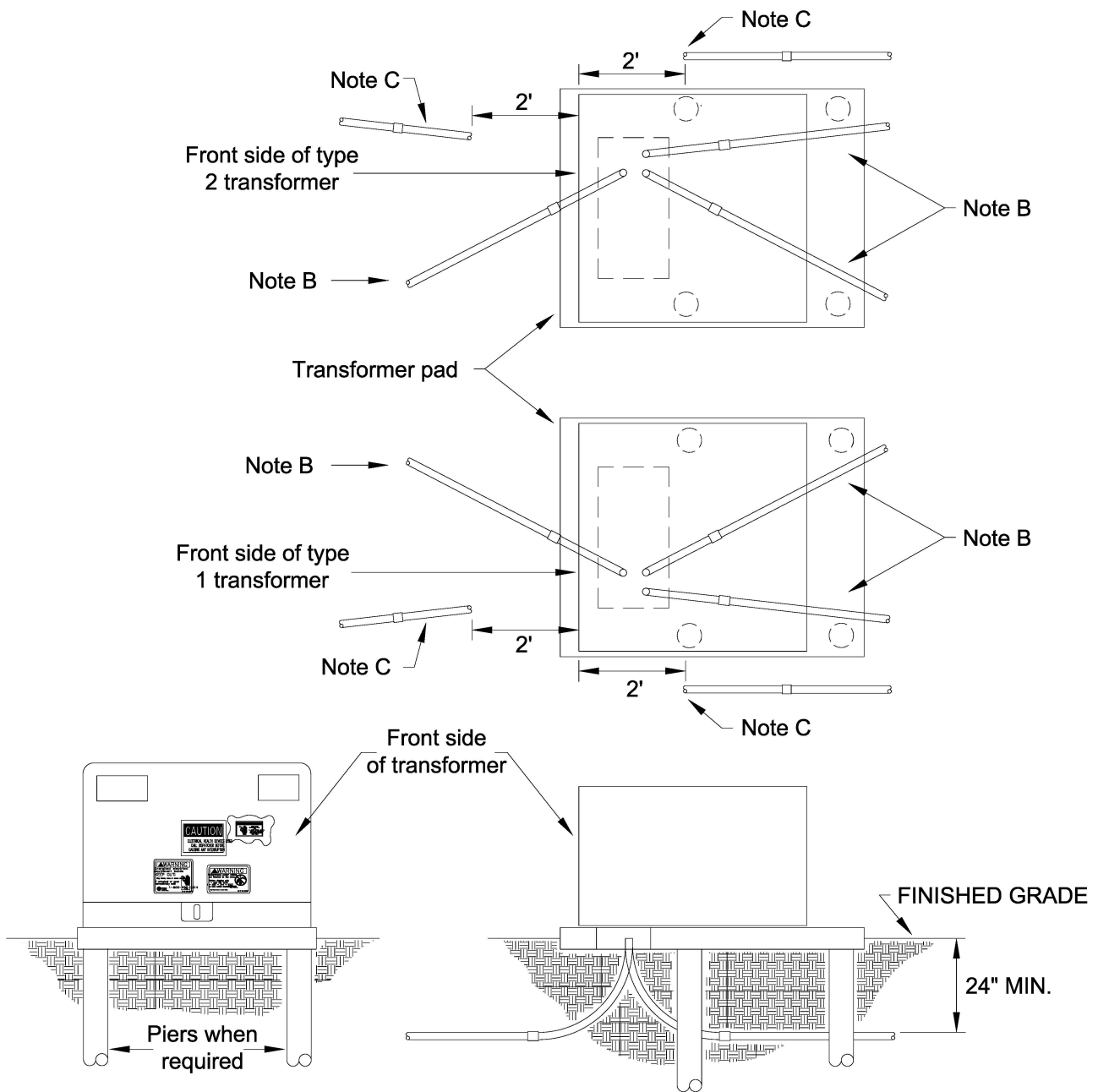

Notes:



- A. Consult company representative for size of conduit to be installed.
- B. Typical location of service conduits for initial installations.
- C. For installation of conduit to in- service transformer pads: bring conduit to within 2' of (1) right front side of transformer for type 1 transformers or (2) left front side of transformer for type 2 transformers. Consult company representative for routing path of conduit to transformer pad window.
- D. Reference detail sheet 12 for bend radius for all horizontal and vertical conduit bends.

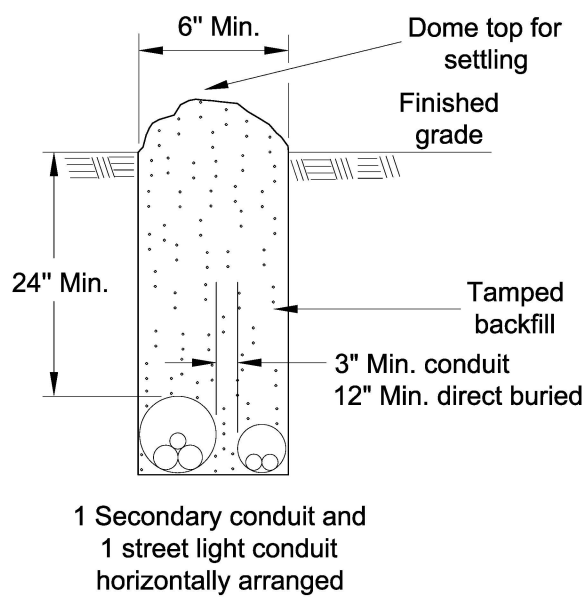
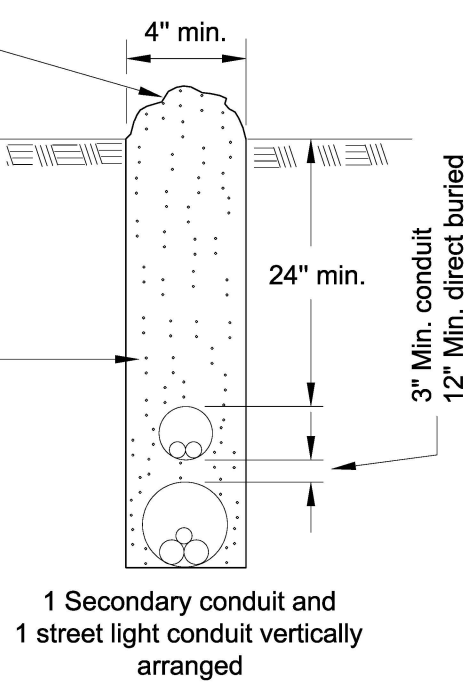
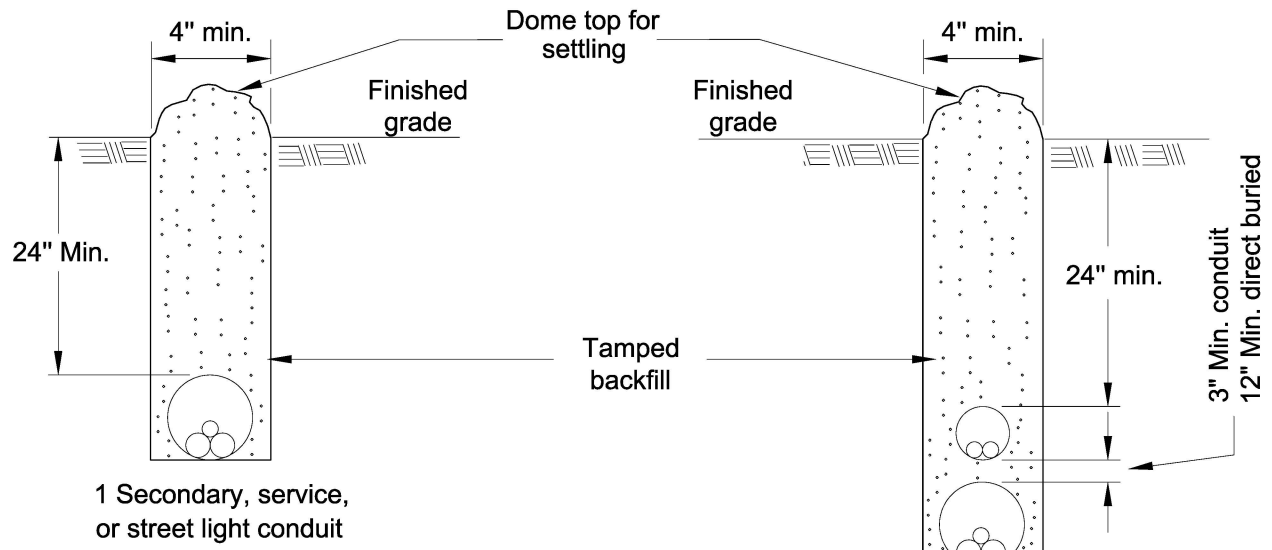

**Typical Service Area-
Transformer Pad**

DDS-1 Detail Sheet 8 of 17



- Legend:
-  Primary cable
 -  Secondary/service cable
 -  Street light cable

- Note:
- A. Consult company representative for conduit size.
 - B. Reference sheets 10 and 11 for notes and instructions.
 - C. Separation dimensions apply to company conduits or cables only. Maintain 12" separation between company conduits or cable and foreign conduits or cable.



Trench Requirements

DDS-1 Detail Sheet 9 of 17

1. Trench alignment shall be as straight as conditions permit. Any deviations from planned alignment shall have prior approval by the project engineer/ inspector. All trench cuts shall be in accordance with existing safety regulations in effect.
2. Trench bottom should be undisturbed, tamped, or relatively smooth earth. Where excavation is in rock, the conduit should be laid on a layer of clean backfill.
3. All backfill should be free of debris or other material that may damage the conduit system or cause settling. The material should fill the voids around the conduit to prevent hot spots & settling.
4. Backfill should be adequately compacted. Backfill not under pavement should be compacted to the density of the surrounding undisturbed soil. Backfill under pavement should be compacted to not less than 95% of the density of undisturbed soil as determined by ASTM D-698.
5. See sheet 11 for instructions for joining pvc conduit.
6. Each conduit run shall be checked by pulling a mandrel through the entire length at the completion of the civil installation.
7. A pull tape shall be left in each conduit. Conduit shall be plugged at both ends.

Approved Pull Tapes

Conduit size	Manufacturer	Catalog no.	TSN
1", 2", 3" & 4"	Arnco Neptco, Inc.	BL-WP25 WP2500P	321068
6"	Arnco Neptco, Inc.	BL-WP60 RP6000N	397616

8. Contact company representative for trench dimensions for more than 2 conduits in same ditch.



**Installation of Conduits
Notes and Instructions**

DDS-1 Detail Sheet 10 of 17

The chemicals used in solvent welding of conduit are intended to penetrate the surface of both pipe and fitting, which after curing result in a complete fusion at the joint. The over-use, or the under-use of chemicals results in leaky joints or weakened pipe.

- A. Clean conduit by wiping off all dust, dirt, and moisture from surfaces to be cemented, either by mechanical or chemical cleaning.
 - 1. Mechanical cleaning - fine abrasive paper or cloth (180 grit or finer) or clean oil-free steel wool.
 - 2. Chemical cleaning - cleaner recommended by manufacturer or equivalent (Methyl Ethyl Ketone - MEK).
- B. With a non-synthetic bristle brush, apply an even coating of cement to the outside of the pipe and inside the socket. Make sure that the amount of cement applied to the conduit is equal to the depth of the socket. Before assembly, if some evaporation of solvent from the surfaces to be joined is noted, reapply cement, then assemble.

If cement being used has an appreciable change in viscosity or shows signs of jelling, it shall be discarded. In no case shall thinner be used in an attempt to restore jelled PVC cement. Thinner may only be used to change the viscosity of a medium bodied cement to that of a regular bodied cement for application on pvc pipe smaller than 2 1/2 inch diameter. A medium bodied cement shall be used on 2 1/2 to 6 inch pvc pipe.

In cold weather, use a primer to soften the joining surfaces before applying cement. Allow longer cure time. (see item E).

- C. Join pipe within 20 seconds of applying cement, turn the pipe 1/4 turn to ensure even distribution of cement on surfaces to be bonded. Make sure that pipe is inserted to the full depth of the socket.
- D. Clean off any bead or excess cement that appears at the outer shoulder of the fitting. Excess cement allowed to remain in contact with the material is apt to cause weakening of the material and subsequent failure.
- E. Newly assembled joints should be handled carefully until the cement has cured the recommended set period. Set periods are related to the ambient temperature as follows:

30 Minute minimum at 60° to 100°F
1 Hr. minimum at 40 to 60°F
2 Hr. minimum at 20 to 40°F
4 Hr. minimum at 0 to 20°F



Instructions for Joining PVC Conduit

DDS-1 Detail Sheet 11 of 17

Conduit nominal size (in.)	Minimum bend radius (in.)	Type of bend material for pulls:
1	18	PVC
2	24	PVC
3	24	PVC
4	24	PVC
6	36	PVC

Notes:

- A. SCH. 80 PVC conduit shall be used for all above ground installations (pole and meter risers). SCH. 40 may be used for all below ground installations.



**Conduit Bend Radius
and Material**

DDS-1 Detail Sheet 12 of 17

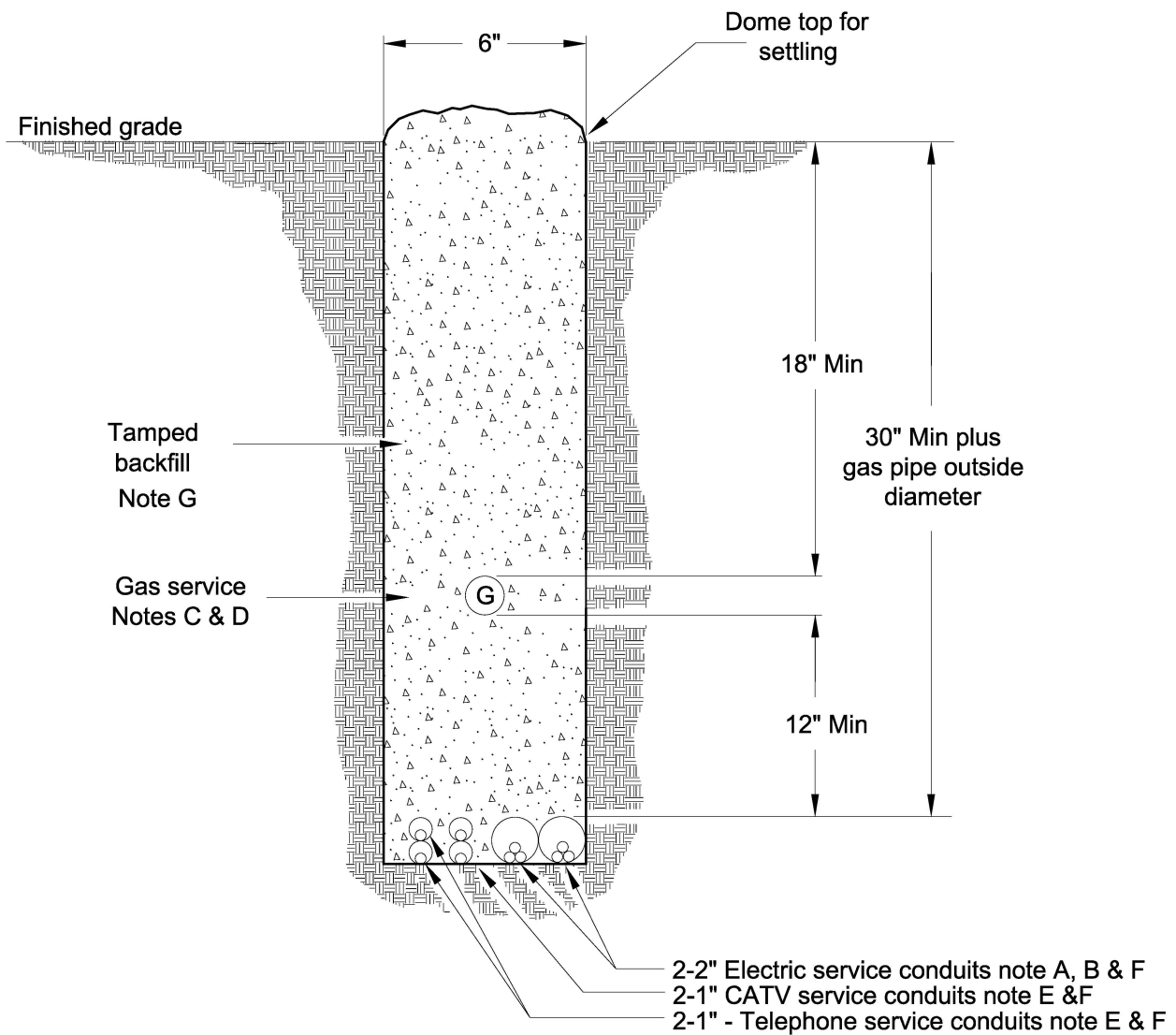

Notes:

- A. Ampacities are reduced for multiple circuits in a trench.
- B. For 120/ 240v single phase or 120/ 208v and 277/ 480v three phase services only.
- C. The gas line in a joint trench shall be polyethylene.
- D. When a gas line crosses under an enclosure such as a pedestal, padmount transformer or splice/pull box, it will be sleeved in a section of polyethylene or schedule 40 pvc. The sleeve will extend a minimum of three feet beyond the edge of the enclosure on each side. Maintain a 12" separation between gas line and electrical supply conduit(s).
- E. Conduit is preferred on CATV and telephone services.
- F. Adequate bonding shall be provided between the supply neutral and the communication shield or sheath at intervals that should not exceed 1000 feet. No bonding is required for entirely dielectric fiber optic communication cables.
- G. Backfill material and compaction shall meet or exceed each utility's specifications.



Joint Service Trench
Public Property

DDS-1 Detail Sheet 13 of 17

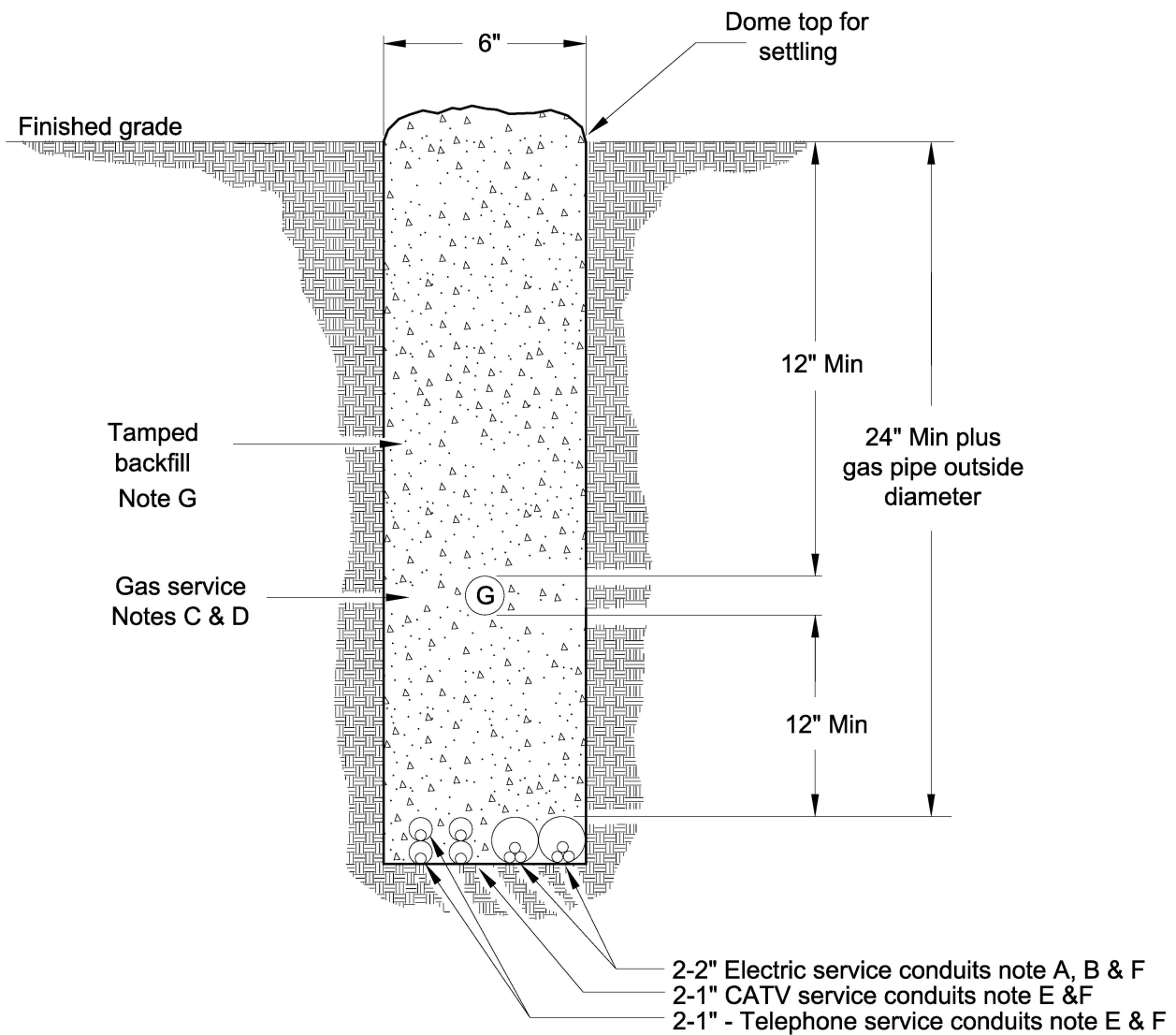

Notes:

- A. Ampacities are reduced for multiple circuits in a trench.
- B. For 120/ 240v single phase or 120/ 208v and 277/ 480v three phase services only.
- C. The gas line in a joint trench shall be polyethylene.
- D. When a gas line crosses under an enclosure such as a pedestal, padmount transformer or splice/pull box, it will be sleeved in a section of polyethylene or schedule 40 pvc. The sleeve will extend a minimum of three feet beyond the edge of the enclosure on each side. Maintain a 12" separation between gas line and electrical supply conduit(s).
- E. Conduit is preferred on CATV and telephone services.
- F. Adequate bonding shall be provided between the supply neutral and the communication shield or sheath at intervals that should not exceed 1000 feet. No bonding is required for entirely dielectric fiber optic communication cables.
- G. Backfill material and compaction shall meet or exceed each utility's specifications.



Joint Service Trench
Private Property

DDS-1 Detail Sheet 14 of 17

Transformer Clearance Details

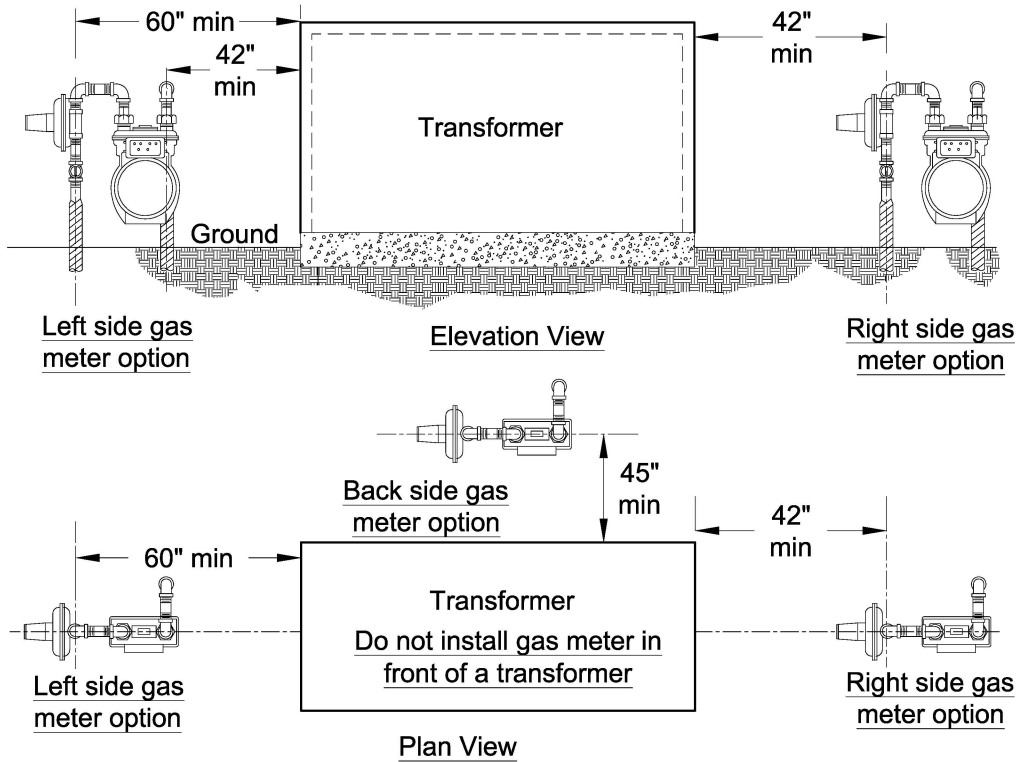

Pedestal Clearance Details

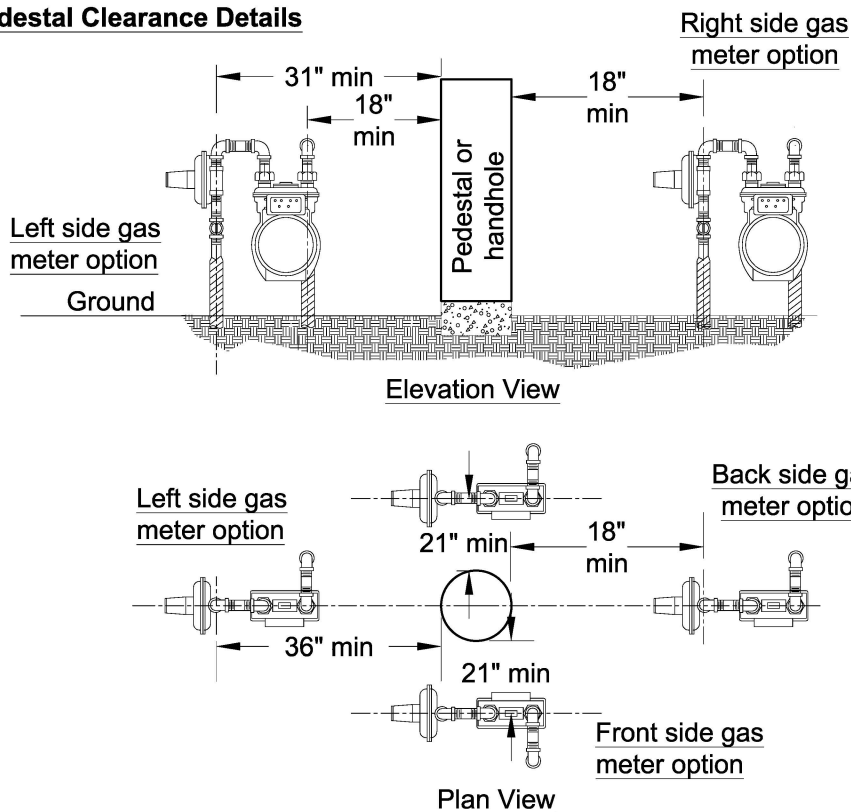

Notes:

- A. Measurements are referenced from the inlet gas riser.
- B. The measurements will ensure:
 1. That a minimum clearance of 36" is attained between the entire gas meter installation and the transformer and
 2. That a minimum clearance of 12" is attained between the entire gas meter installation and all other aboveground facilities including electric and other utility pedestals and handholes.
- C. This standard applies to 630 gas meter installations and smaller. For larger meter installations, contact company representative for assistance.
- D. This drawing is typically used when the gas main is located in an alley or dedicated utility easement.



Aboveground Clearances from Gas Meter Installations

DDS-1 Detail Sheet 15 of 17

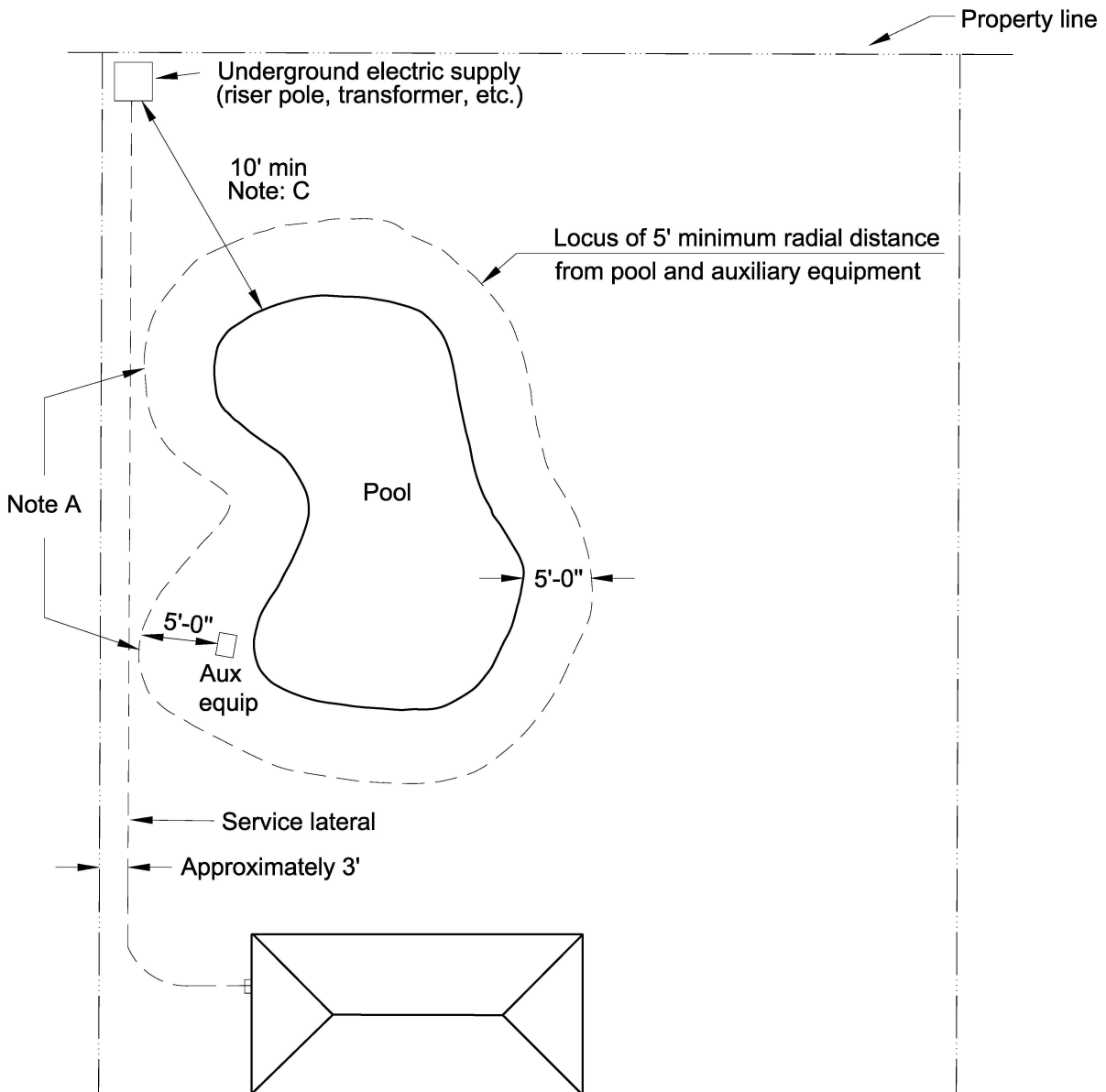

Notes:

- A. A swimming pool or its auxiliary equipment or water pipes shall not be installed within 5 feet of an existing direct buried underground service lateral.
- B. Where a swimming pool must be installed within 5 feet of existing items mentioned in note A, the client shall provide and install a conduit including pull wire from the service connection point to the meter.
- C. Padmounted equipment must be located 10 feet or more from the water's edge.



Location of Service Lateral
Near a Swimming Pool

DDS-1 Detail Sheet 16 of 17

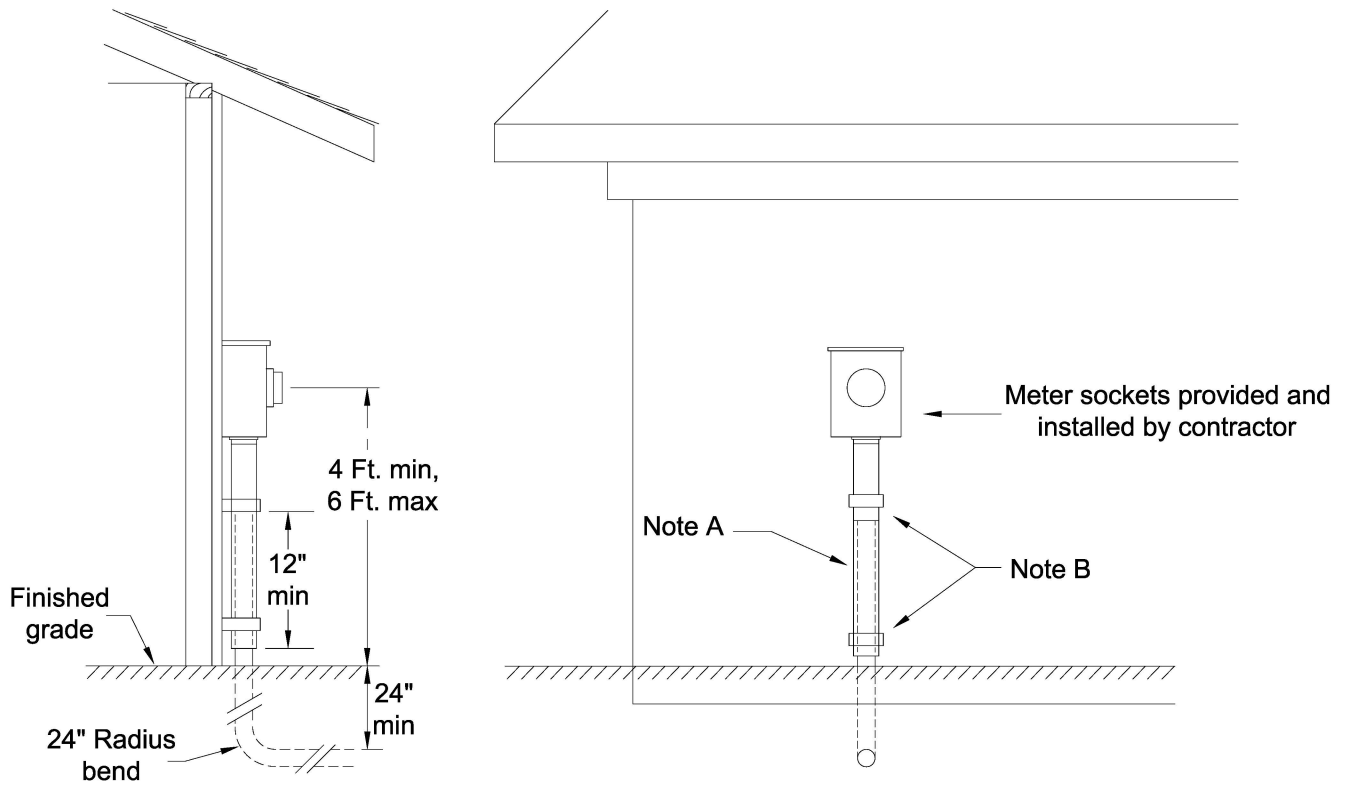

Typical Meter Installation



Meter Sockets-Single and Duplex
Note C

Notes:

- A. Meter riser shall be schedule 80 PVC. exemption: schedule 40 PVC is acceptable if permitted by local code and riser is not placed in the vicinity of a driveway or subject to physical damage.
- B. Two 2- hole straps may be required by the inspecting authority.
- C. Reference Oncor's "Electric Service Guidelines" for meter information.



Metering Information

DDS-1 Detail Sheet 17 of 17