



TRANSMISSION STANDARDS

520-106 Guideline - Facility Interconnection Requirements for Points of Delivery at Transmission Voltages with Retail Customers

INITIAL RELEASE DATE: December 30, 2005

LAST REVISION DATE: November 21, 2023

LAST REVIEW DATE: November 21, 2023

1.0 Scope

- 1.1 This guide applies to the interconnection of a Customer with the Company's system via a new or existing interconnection at transmission voltages (69 kV and higher), in compliance with the latest version of NERC Reliability Standard FAC-001.
- 1.2 This guide does not apply to a Point of Delivery capable of bi-directional power transfer.
- 1.3 The interconnection arrangements covered in this guide are not intended to cover all possible scenarios. Interconnection scenarios that differ from the arrangements covered in this guide will be addressed on a case-by-case basis.
- 1.4 Company reserves the right to deviate from the requirements specified in this guide based on the circumstances specific to a given Point of Delivery.
- 1.5 Interconnections will be provided in accordance with the Regulations specified herein. In the event of a conflict between this guide and the Regulations, the Regulations will control.
- 1.6 This guide is subject to revision at the sole discretion of Company. It is Customer's responsibility to request and comply with the latest revision of this guide.

2.0 Definitions

- 2.1 ANSI Standards – American National Standards Institute Standards
- 2.2 Customer – An end-use retail customer who purchases electric power and energy and ultimately consumes it.
- 2.3 Company – Oncor Electric Delivery Company LLC or its successors and assigns (Oncor).
- 2.4 Customer's Facilities or Customer Facilities – Customer-owned electric lines, electrical equipment, protection equipment and other facilities that function as part of Customer's electric system and which must be used, installed and/or modified to accept electrical service from Company's Facilities.
- 2.5 Company's Facilities or Company Facilities – Company-owned electric lines, electrical equipment, protection equipment, metering equipment, and other facilities that function as part of Company's electric system and which must be used, installed and/or modified to deliver electrical service from Company's transmission system to the Customer's Facilities.
- 2.6 ERCOT – Electric Reliability Council of Texas.
- 2.7 Good Utility Practice – Shall have the meaning as specified in the PUCT Substantive Rules Section 25.5.
- 2.8 IEEE Standards – Institute of Electrical and Electronic Engineers Standards
- 2.9 NERC Reliability Standards – North American Electric Reliability Corporation Reliability Standards

Oncor Proprietary Information

TRANSMISSION STANDARDS

520-106 Guideline - Facility Interconnection Requirements for Points of Delivery at Transmission Voltages with Retail Customers

INITIAL RELEASE DATE: December 30, 2005

LAST REVISION DATE: November 21, 2023

- 2.10 Point of Delivery (POD) – The point of interconnection where the Company’s conductors are connected to the Customer’s conductors and a change of ownership occurs.
- 2.11 PUCT – Public Utility Commission of Texas.
- 2.12 Qualified Change – This term is defined by ERCOT. If the work requested by the Customer meets the definition of “Qualified Change” that is in effect in ERCOT at the time of the Customer’s request, then the Company will treat the requested work as a “Qualified Change” for purposes of this document.
- 2.13 Regulations - Laws, regulations, tariffs, and agreements between Company and Customer applicable to the services provided under this guide.
- 2.14 Tariff – Oncor Tariff for Retail Delivery Service approved by the PUCT. Such Tariff is available on the Company website at: <http://www.oncor.com/EN/Pages/Transmission-Facility-Connection-Requirements.aspx>.

3.0 NERC Reliability Standard FAC-001 Facility Connection Requirements

3.1 Procedures for coordinated studies of new interconnections or existing interconnections seeking to make a Qualified Change and their impacts on affected systems

Company will perform assessments of the reliability impacts of new Points of Interconnection or a requested Qualified Change to existing Points of Interconnection, in accordance with the Oncor Assets Planning Processes Procedures Guide. Such procedures are available upon request.

3.2 Procedures for notifying those responsible for the reliability of affected system(s) of new interconnections or existing interconnections seeking to make a Qualified Change

3.2.1 Company will notify ERCOT of new interconnections or existing interconnections seeking to make a Qualified Change to transmission facilities as required by the ERCOT Nodal Protocols Section 3.10.

3.2.2 Company will provide advance notice to ERCOT of its future plans to make a Qualified Change to its transmission system in accordance with Oncor Transmission Standard 100-001, *NOMCR Process*. At the time such Qualified Change is to be made, Company will obtain approval from ERCOT for the Qualified Change prior to making such change and will notify ERCOT when a Qualified Change is implemented, both in accordance with Company’s Transmission Grid Organization Procedure SOP-200, *New or Modified Equipment Facilities*.

3.3 Procedures for confirming with those responsible for the reliability of affected systems that new transmission Facilities or existing transmission Facilities seeking to make a Qualified Change are within a Balancing Authority Area’s metered boundaries

3.3.1 The ERCOT Nodal Operating Guides Section 5.1, System Modeling Information, requires each Transmission Service Provider, or its Designated Agent, to provide accurate modeling information for all transmission facilities owned or planned by the

Oncor Proprietary Information



TRANSMISSION STANDARDS

520-106 Guideline - Facility Interconnection Requirements for Points of Delivery at Transmission Voltages with Retail Customers

INITIAL RELEASE DATE: December 30, 2005

LAST REVISION DATE: November 21, 2023

Transmission Service Provider, including, but not limited to, information necessary to represent the Transmission Service Provider's transmission facilities in any model of the ERCOT Transmission Grid whose creation has been approved by ERCOT.

3.3.2 The ERCOT Nodal Protocols Section 3.10, Network Operations Modeling and Telemetry, provides that ERCOT shall use the physical characteristics, ratings, and operational limits of all Transmission Elements of the ERCOT Transmission Grid and other information from Transmission Service Providers and Resource Entities to specify limits within which the transmission network is defined in the network models that are made available to market participants and used to operate the ERCOT Transmission Grid. ERCOT uses a Network Operations Model Change Request (NOMCR) process to control all information entering the Network Operations Model. Any request for any change in system topology or telemetry must receive approval from ERCOT before connecting a new transmission facility or an existing transmission facility that has undergone a Qualified Change.

3.3.3 Company will provide modeling changes to ERCOT in accordance with ERCOT Nodal Operating Guides Section 5, Network Operations Modeling Requirements, to request changes in system topology or telemetry for new transmission facilities or existing transmission facilities seeking to make a Qualified Change. Company will provide such modeling changes in accordance with Oncor Transmission Standard 100-001, NOMCR Process. ERCOT's approval of a Qualified Change to the Network Operations Model will serve as Company's confirmation that a new transmission facility or an existing transmission facility seeking to make a Qualified Change is within the ERCOT metered boundaries.

3.4 Voltage Level and MW and MVAR Demand

3.4.1 Company's transmission voltages are 69 kV, 138 kV, and 345 kV. The actual voltage for a Point of Delivery will be determined through analyses performed by Company. Not all voltages may be available to Customer at its location.

3.4.2 Customer will provide its load information in accordance with Section 4.1.8 below.

3.4.3 Customer will comply with Section 3.9 below regarding MVAR demand.

3.5 Breaker Duty and Surge Protection

3.5.1 Customer will comply with Section 5.2.1 below.

3.5.2 Customer's transmission voltage facilities directly connecting to the POD should meet the applicable IEEE Standards for direct lightning stroke shielding and surge arrester protection, including, but not limited to, the latest revision of IEEE Standards 998 and C62.22.

3.6 Metering and Telecommunication

3.6.1 Metering of service at each POD is required. The metering configuration will be determined on a per case basis. Company may at its option, install metering at the POD or on the low-side of Customer's transformer. An adder for loss compensation shall be used for metering installed on the low side of Customer's transformer.



TRANSMISSION STANDARDS

520-106 Guideline - Facility Interconnection Requirements for Points of Delivery at Transmission Voltages with Retail Customers

INITIAL RELEASE DATE: December 30, 2005

LAST REVISION DATE: November 21, 2023

3.6.2 If Company meters on the low side of Customer's transformer, Company shall provide a metering enclosure, metering voltage transformers (VTs) and current transformers (CTs) or reimburse Customer for the cost of Company specified, Customer purchased transformers. The Customer shall be responsible for installing the metering enclosure, the VTs and CTs and all associated fuses, structures, foundations, conduit, lockable junction boxes, Company specified cable, and grounding. The exact location of metering will be determined on a per case basis. VTs and CTs shall be installed so as to provide Company employees easy access without unnecessary intrusion into Customer's Facilities. The standard location for the installation of Company's metering enclosure shall be outside the Customer's substation fence. Customer shall be responsible for installing Company specified conduit and cable directly from the metering transformers to the metering enclosure. Company will complete and terminate the cable at the junction boxes and metering enclosure. If the installation of free standing VTs and CTs is not an option due to space limitations Customer may request an exception to install the VTs and CTs in Customer's switchgear. Company shall review request for exception on a per case basis and Customer must give Company sufficient notice for the VTs and CTs to be installed in Customer's switchgear before the switchgear is fabricated. Prior to procurement and construction, Customer will provide to Company for review drawings sufficient to show in detail the aforementioned equipment, including a one-line diagram.

3.6.3 Customer will not install bypasses around any Company CTs.

3.7 Grounding and Safety Issues

3.7.1 Customer will ground its transmission voltage equipment at the POD in accordance with applicable IEEE Standards, including, but not limited to, the latest revision of IEEE Standard 80.

3.7.2 Customer and Company will coordinate switching and tagging of switches at a POD in accordance with Company's procedures. Such procedures will be made available to Customer upon request.

3.8 Insulation and Insulation Coordination

Customer will meet the applicable requirements of the applicable IEEE Standards with respect to insulation, insulation coordination, and electrical clearances for its facilities at the POD, including, but not limited to, the latest version of IEEE Standards 1313.1, 1313.2, and 1427.

3.9 Voltage, Reactive Power, and Power Factor Control

Customer will comply with the applicable provisions of the Tariff with respect to the power factor of its load.

3.10 Power Quality Issues

Customer will comply with the applicable provisions of the Tariff and Section 5.2.2 below with respect to its obligations not to create adverse effects on Company's transmission system.



TRANSMISSION STANDARDS

520-106 Guideline - Facility Interconnection Requirements for Points of Delivery at Transmission Voltages with Retail Customers

INITIAL RELEASE DATE: December 30, 2005

LAST REVISION DATE: November 21, 2023

3.11 Equipment Ratings

Customer's equipment will be rated in accordance with applicable ANSI Standards, including, but not limited to, the latest version of ANSI Standards C84.1 and C92.2.

3.12 Maintenance Coordination

Company and Customer will conduct maintenance activities on their respective facilities in accordance with the applicable provisions of the Tariff.

3.13 Operational Issues (abnormal frequency and voltages)

Abnormal voltage and frequency may occur at a POD as is described in the Tariff. Customer is responsible for installing necessary equipment to protect its system in the event of abnormal voltage or frequency as is described in the Tariff.

3.14 Inspection Requirements

3.14.1 Customer shall have the responsibility for inspecting the Customer Facilities to determine if such Facilities have been constructed in accordance with all requirements applicable to such facilities.

3.14.2 Customer is responsible for obtaining all electrical inspections required by governmental authorities having jurisdiction.

3.15 Communications and Procedures during normal and emergency operating conditions

Company and Customer will communicate with each other in accordance with the applicable provisions of the Tariff and Section 7 below.

4.0 Customer Information

4.1 Customer will provide the following information to Company and secure from Company a commitment to interconnect Customer's Facilities with Company's Facilities prior to Customer finalizing the design of Customer's Facilities:

4.1.1 Desired in-service date for requested POD or for a Qualified Change to POD.

4.1.2 Physical location of proposed POD or the location of the transmission Facility that is subject to the requested Qualified Change.

4.1.3 Company's transmission line structure number for each structure on either side of the proposed POD if (1) Customer is requesting POD that is to an existing transmission circuit or (2) Customer is requesting a Qualified Change to an existing transmission circuit.

4.1.4 Voltage at which interconnection is being requested.

4.1.5 Length and calculated positive and zero sequence impedance of the transmission line extension from the POD, if Customer plans to build a line extension.



TRANSMISSION STANDARDS

520-106 Guideline - Facility Interconnection Requirements for Points of Delivery at Transmission Voltages with Retail Customers

INITIAL RELEASE DATE: December 30, 2005

LAST REVISION DATE: November 21, 2023

- 4.1.6 One-line electrical diagram of proposed Customer Facilities, both initial and ultimate.
- 4.1.7 Proposed transformer ratings, including:
 - Voltages and winding connections,
 - MVA (both base and maximum ratings), and
 - Impedances (both positive and zero sequence at base rating).
- 4.1.8 Initial and five-year load projections (MW), including peak load power factor at the POD.
- 4.1.9 List of all motors greater than 500 horsepower associated with the load addition and the following information for each motor listed:
 - Horsepower rating of each motor,
 - Code (A, B, C, D, etc.),
 - Rated voltage, and
 - Minimum starting voltage.
- 4.1.10 Size, voltage, and impedance of any step-down transformers.
- 4.1.11 Special service requirements (e.g., information on special requirements for Customer's manufacturing processes).
- 4.1.12 Relay functional diagram of Customer's proposed Facilities for Company's review will specifically include all facilities that may impact Company's system and relaying performance.
- 4.1.13 Drawings of proposed physical facilities, including initial installation and any anticipated future additions.
- 4.1.14 Surveyed or detailed site plan showing proposed Customer Facilities in proximity to existing Company Facilities.

5.0 Construction and Ownership

5.1 Company's Facilities

- 5.1.1 Company's Facilities will be designed, installed, owned, and operated by Company. Company will perform all maintenance work related to Company's Facilities.
- 5.1.2 Company will determine requirements for relaying protection of Company's Facilities and will specify and implement protection and control schemes to meet such requirements. Company will work with the Customer to determine protection requirements of Customer's Facilities necessary to provide coordination with protection of Company's Facilities.
- 5.1.3 Company will have no obligation to begin design, procurement of materials, construction of Company's Facilities, or make other project specific improvements until Customer and Company have completed contractual arrangements.



TRANSMISSION STANDARDS

520-106 Guideline - Facility Interconnection Requirements for Points of Delivery at Transmission Voltages with Retail Customers

INITIAL RELEASE DATE: December 30, 2005

LAST REVISION DATE: November 21, 2023

5.1.4 Company will not begin construction of Company's Facilities within Customer's property until any required easement and/or right-of-way has been provided, the required environmental site assessments have been made, and the required permitting requirements have been met.

5.1.5 At Points of Delivery where existing Company Facilities are not equipped with ac and/or dc service and new Company Facilities will require ac and/or dc service and Customer's Facilities are or will be equipped with ac and/or dc service, Customer will, if requested by Company, provide the necessary ac and/or dc service to Company's Facilities at no cost to Company.

5.1.6 Company will install a full tension conductor dead-end structure in the Company's transmission line if a tap point is required. Company will also own all facilities in Company's through flow transmission current path. All switches in Company's through flow path will be operated by or under the dispatch authority of Company. The Customer's line extension will contact Company Facilities at slack tension. Company will determine the exact tension requirements for each installation in cooperation with the Customer.

5.2 Customer's Facilities

5.2.1 Customer will be responsible for the design, installation, ownership, operation, and protection of Customer's Facilities. Customer's protective equipment will be fully rated to interrupt available fault current (See Section 6).

5.2.2 Customer's Facilities, and any modifications thereof, will meet all applicable national, state, and local construction, operation, and safety codes. Design of Customer's Facilities is subject to Company's review as to suitability for safe, compatible, and reliable operation with Company's system so as not to reduce or adversely impact the quality of electric service being provided by Company to all customers.

5.2.3 Customer's Facilities will be constructed and operated in accordance with Company's Tariff and any applicable agreement.

5.2.4 Customer will submit to Company proposed modifications to Customer Facilities prior to making the modifications so that Company can determine if the proposed modifications will impact Company Facilities.

5.2.5 A manual or motor operated switch with visible break for the purpose of isolating Customer's Facilities from Company's Facilities will be provided by Customer. Such switch shall be accessible to Company personnel for operation at all times, and shall be capable of being locked in an open position by Company and Customer. (See Section 6.1)

5.2.6 Customer will provide relay settings and relay testing documentation to Company certifying that all protection equipment has been properly adjusted and trip tested before Customer's Facilities are placed in service.

5.2.7 Customer will provide space for the installation of a wave trap if the transmission line utilizes carrier relaying.



TRANSMISSION STANDARDS

520-106 Guideline - Facility Interconnection Requirements for Points of Delivery at Transmission Voltages with Retail Customers

INITIAL RELEASE DATE: December 30, 2005

LAST REVISION DATE: November 21, 2023

5.2.8 The location of Customer's Facilities on Company's transmission system along with the characteristics of the Customer's equipment may result in a situation where the transmission line's power line carrier signal is negatively impacted. If normal mitigating techniques do not resolve this problem Company may install a wave trap at the POD.

6.0 System Protection Requirements

The system protection requirements for Company and Customer are described in the sections below. The system protection requirements for a specific POD depend on several factors, including the location of Customer's substation and Company's existing line protection system.

The protection systems and associated equipment required to be installed as part of Customer's Facilities can be determined using Section 6.1.

The protection systems and associated equipment to be installed as part of Company's Facilities can be determined using Section 6.2.

6.1 Customer Equipment Requirements

Customer will provide, install and maintain the equipment necessary to automatically disconnect Customer's Facilities from Company's Facilities in the event of a fault on Customer's Facilities.

6.1.1 If the Customer's substation is less than 1000 feet from Company's transmission line, the requirements at the Customer's substation are:
(Figure 1)

- Customer will install at least two independent fault sensing systems. Separate relays and CTs shall be used in each system.
- Customer will install at least two disconnect devices. The primary clearing device will complete a disconnection within 6 cycles. The backup disconnect device will visibly isolate the faulted equipment within 5 seconds, coordinate with Company's system, and not adversely affect other customers. A motor-operated disconnect switch meets the visible backup disconnect device requirement if the primary clearing device is a circuit breaker. A circuit switcher that incorporates a motor-operated air break switch also meets the requirement of a primary clearing device and a visible backup disconnect device.
- If the Customer chooses to use a fuse as the clearing device, the visible disconnect device will be a three-phase gang-operated air switch and is not required to be motor-operated. Customer will be responsible for all risk associated with the exposure to ferroresonance, single phasing and other negative effects potentially caused by the fuses. To ensure coordination, Company will review Customer's choice of disconnect device.
- If the Customer installs a bypass switch around the Customer's disconnect devices, it shall be used for validating the operation of the disconnect devices only. If maintenance is required a clearance must be taken. The bypass switch shall not be closed without notifying Company's transmission system dispatcher.

Oncor Proprietary Information



TRANSMISSION STANDARDS

520-106 Guideline - Facility Interconnection Requirements for Points of Delivery at Transmission Voltages with Retail Customers

INITIAL RELEASE DATE: **December 30, 2005**

LAST REVISION DATE: **November 21, 2023**

Company's relaying exists solely for the purpose of protecting Company's facilities and does not exist to provide protection for facilities not owned by Company.

Oncor Proprietary Information



TRANSMISSION STANDARDS

520-106 Guideline - Facility Interconnection Requirements for Points of Delivery at Transmission Voltages with Retail Customers

INITIAL RELEASE DATE: December 30, 2005
LAST REVISION DATE: November 21, 2023

Figure 1

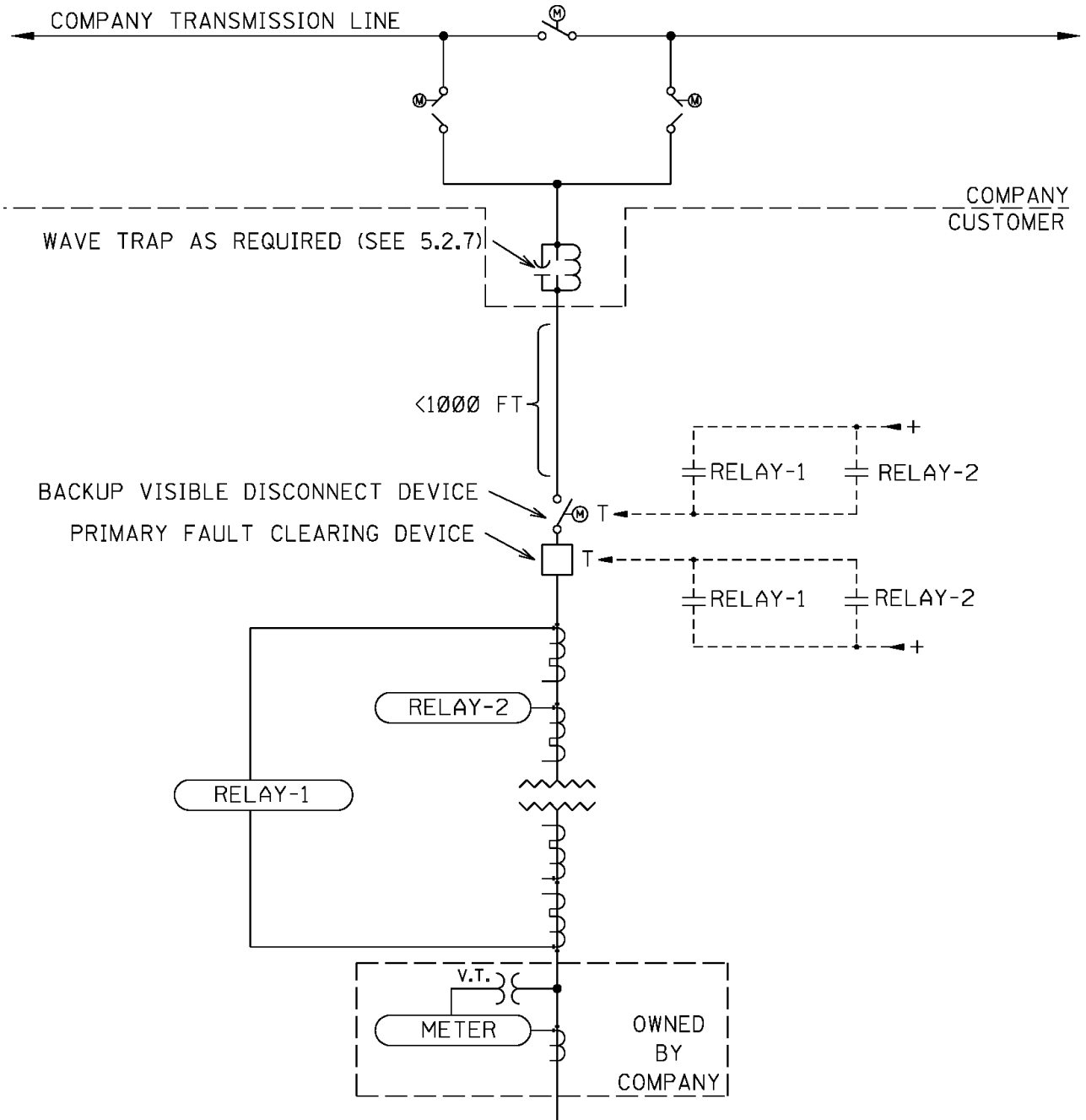

**TRANSMISSION STANDARDS****520-106 Guideline - Facility Interconnection Requirements for Points of Delivery at Transmission Voltages with Retail Customers****INITIAL RELEASE DATE: December 30, 2005****LAST REVISION DATE: November 21, 2023**

6.1.2 If the Customer's substation is greater than 1000 feet from Company's transmission line, the requirements at Customer POD are:
(Figure 2)

- Customer will install at least two independent fault current sensing systems. Separate relays and CTs shall be used in each system. The independent relays shall be set to instantaneously trip the Customer's breaker for faults on the Customer's transmission voltage equipment. The relays shall be set to reach into the Customer's substation transformer and detect any faults occurring at the transmission voltage on Customer's equipment.
- Customer will install a circuit breaker with a maximum clearing time of 3 cycles. To ensure coordination, Company will review Customer's choice of circuit breaker.
- Customer will install a visible disconnect that allows Customer's Facilities to be isolated from Company's Facilities.
- If the Customer installs a bypass switch around the Customer's circuit breaker, it shall be used for validating the operation of the breaker only. If maintenance is required, a clearance must be taken. The bypass switch shall not be closed without notifying Company's transmission system dispatcher. Company's relaying exists solely for the purpose of protecting Company's facilities and does not exist to provide protection for facilities not owned by Company.
- Customer's remote substation shall meet the requirements described in Section 6.1.1.



TRANSMISSION STANDARDS

520-106 Guideline - Facility Interconnection Requirements for Points of Delivery at Transmission Voltages with Retail Customers

INITIAL RELEASE DATE: December 30, 2005
LAST REVISION DATE: November 21, 2023

Figure 2

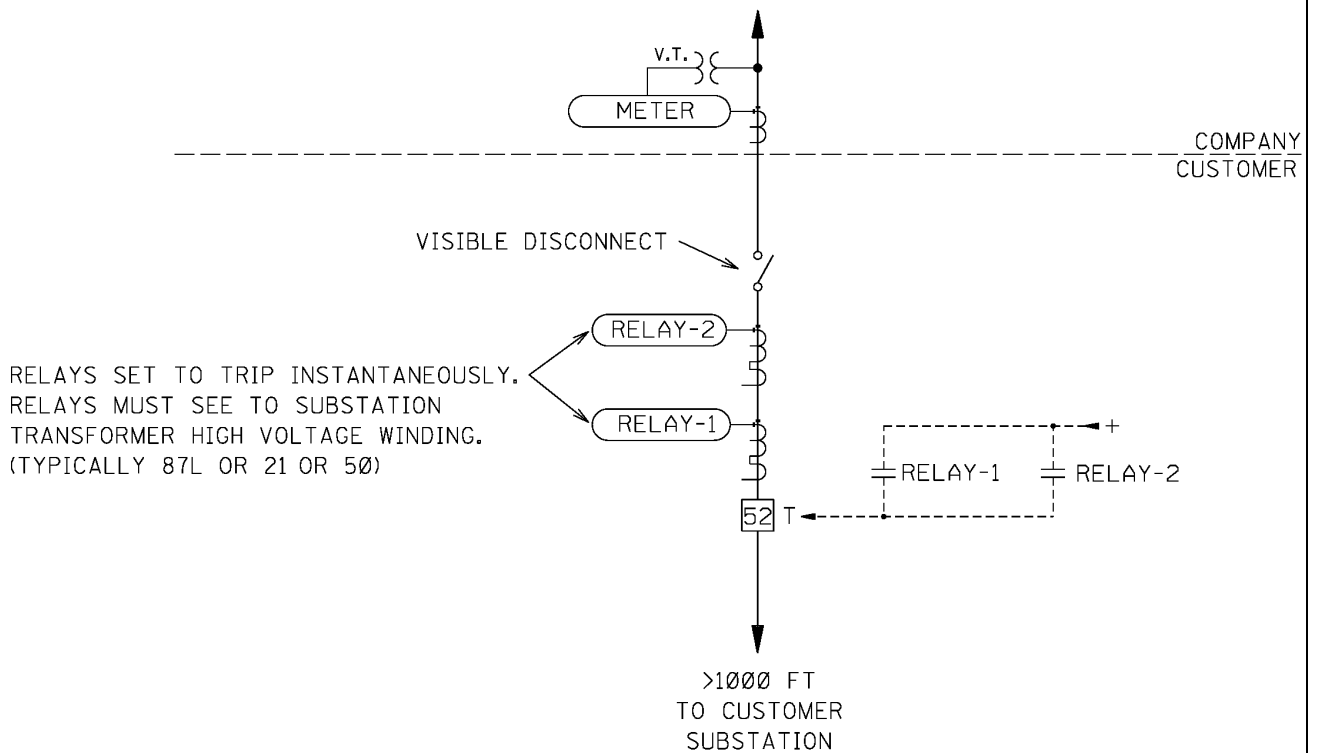

Oncor Proprietary Information



TRANSMISSION STANDARDS

520-106 Guideline - Facility Interconnection Requirements for Points of Delivery at Transmission Voltages with Retail Customers

INITIAL RELEASE DATE: December 30, 2005

LAST REVISION DATE: November 21, 2023

6.2 Company Equipment Requirements

6.2.1 If the Customer substation is less than 1000 feet from Company's transmission line, the Company will install:
(Figure 3)

- Air switches to sectionalize Company's existing line. The switches may be manually operated or motor operated.
- Wave trap in Customer's Facilities if required (see Section 5.2.7).
- Revenue metering equipment (see Section 3.6).

Oncor Proprietary Information



TRANSMISSION STANDARDS

520-106 Guideline - Facility Interconnection Requirements for Points of Delivery at Transmission Voltages with Retail Customers

INITIAL RELEASE DATE: December 30, 2005
LAST REVISION DATE: November 21, 2023

Figure 3

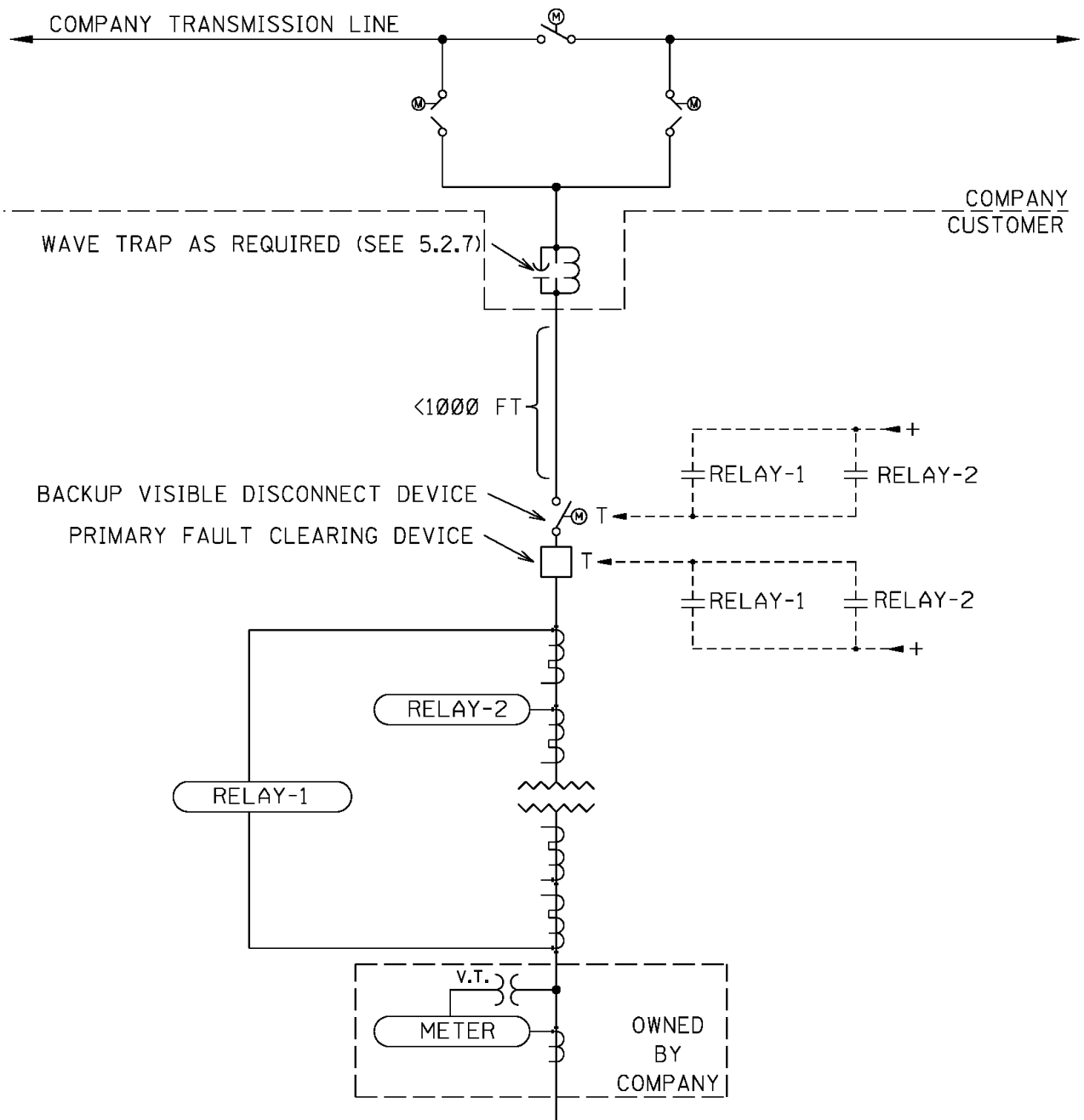



TRANSMISSION STANDARDS

520-106 Guideline - Facility Interconnection Requirements for Points of Delivery at Transmission Voltages with Retail Customers

INITIAL RELEASE DATE: December 30, 2005
LAST REVISION DATE: November 21, 2023

6.2.2 If the Customer substation is greater than 1000 feet from Company's transmission line, the Company equipment guidelines are:

6.2.2.1 If no pilot relaying exists on Company's line and Company's relaying can adequately detect faults to the end of Customer's transmission line extension, Company will install:
 (Figure 4)

- Air switches to sectionalize Company's existing line. The switches may be manually operated or motor operated.
- Revenue metering equipment (see Section 3.6).

Figure 4

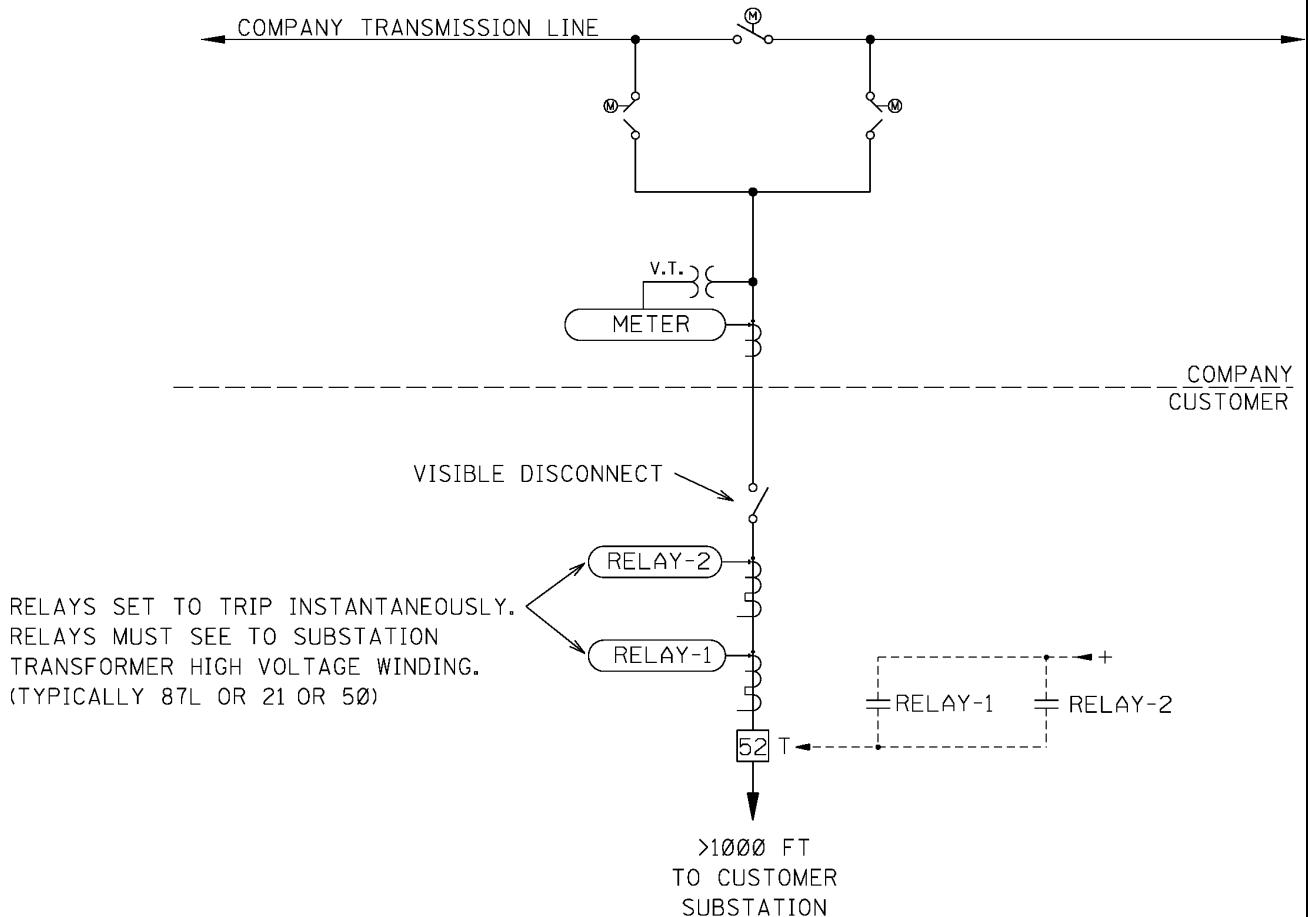



TRANSMISSION STANDARDS

520-106 Guideline - Facility Interconnection Requirements for Points of Delivery at Transmission Voltages with Retail Customers

INITIAL RELEASE DATE: December 30, 2005

LAST REVISION DATE: November 21, 2023

6.2.2.2 If no pilot relaying exists on Company's line and Company's relaying cannot adequately detect faults to the end of Customer's transmission line extension, Company will install:
(Figure 5)

- Air switches to sectionalize Company's existing line. The switches may be manually operated or motor operated.
- A motor-operated air switch (MOAS) as part of the breaker failure backup protection to isolate Customer's Facilities from Company's Facilities.
- Relaying to provide breaker failure detection and trip the MOAS.
- A single-phase high-speed grounding switch connected on the Customer's side of the MOAS.
- Revenue metering equipment (see Section 3.6).



TRANSMISSION STANDARDS

520-106 Guideline - Facility Interconnection Requirements for Points of Delivery at Transmission Voltages with Retail Customers

INITIAL RELEASE DATE: December 30, 2005
LAST REVISION DATE: November 21, 2023

Figure 5

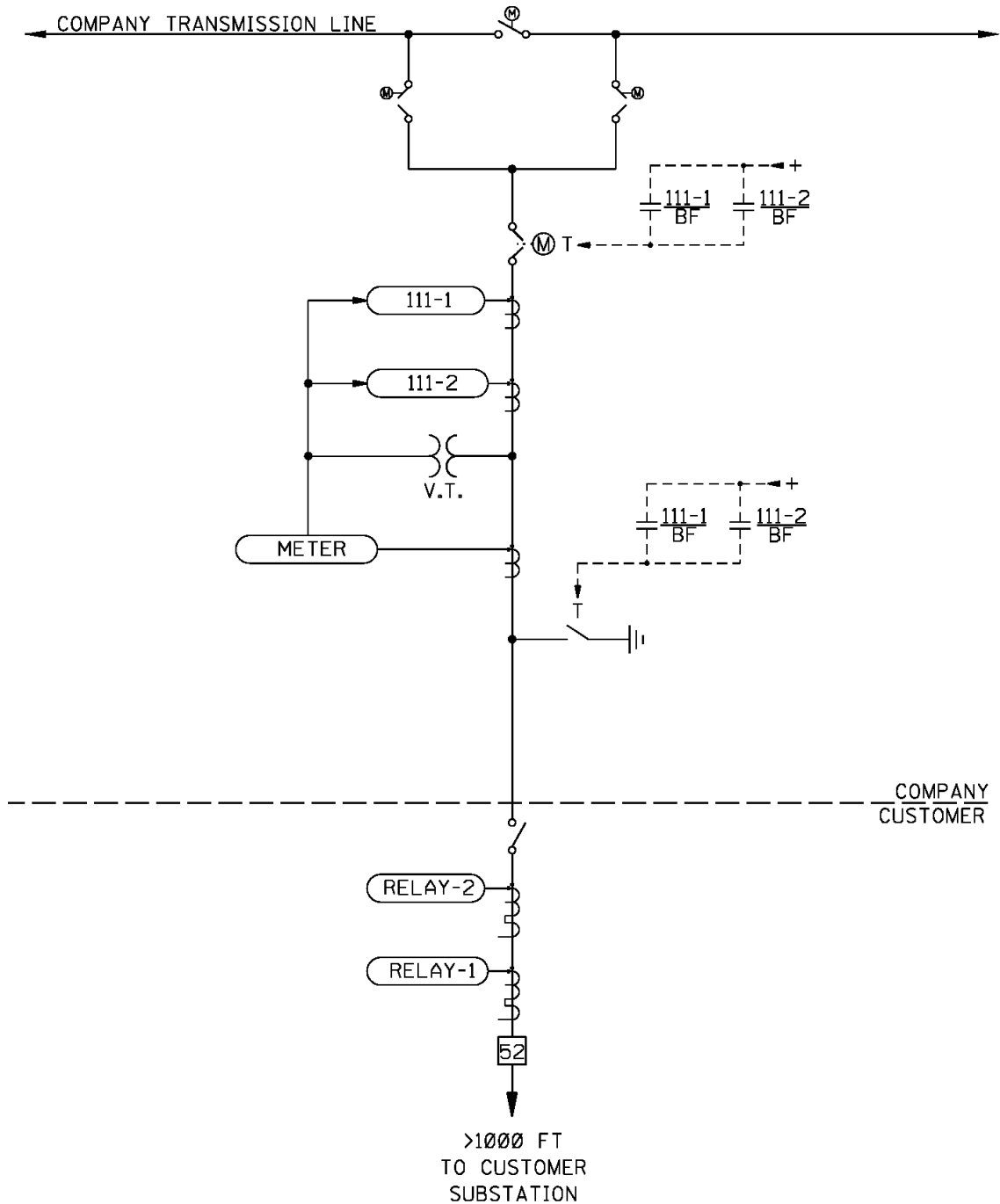



TRANSMISSION STANDARDS

520-106 Guideline - Facility Interconnection Requirements for Points of Delivery at Transmission Voltages with Retail Customers

INITIAL RELEASE DATE: December 30, 2005

LAST REVISION DATE: November 21, 2023

6.2.2.3 If pilot relaying exists on Company's line and Company's relaying can adequately detect faults to the end of Customer's transmission line extension, Company will install:
(Figure 6)

- Air switches to sectionalize Company's existing line. The switches may be manually operated or motor operated.
- A motor-operated air switch (MOAS) as part of the breaker failure backup protection to isolate Customer's Facilities from Company's Facilities.
- Relaying to provide breaker failure detection, blocking and trip the MOAS.
- Communication equipment to establish a blocking terminal. The blocking terminal is installed to prevent Company's remote terminals from tripping on high-speed relaying when a fault occurs on Customer's line extension.
- Wave trap if pilot relaying utilizes power line carrier.
- Revenue metering equipment (see Section 3.6).



TRANSMISSION STANDARDS

520-106 Guideline - Facility Interconnection Requirements for Points of Delivery at Transmission Voltages with Retail Customers

INITIAL RELEASE DATE: December 30, 2005
LAST REVISION DATE: November 21, 2023

Figure 6

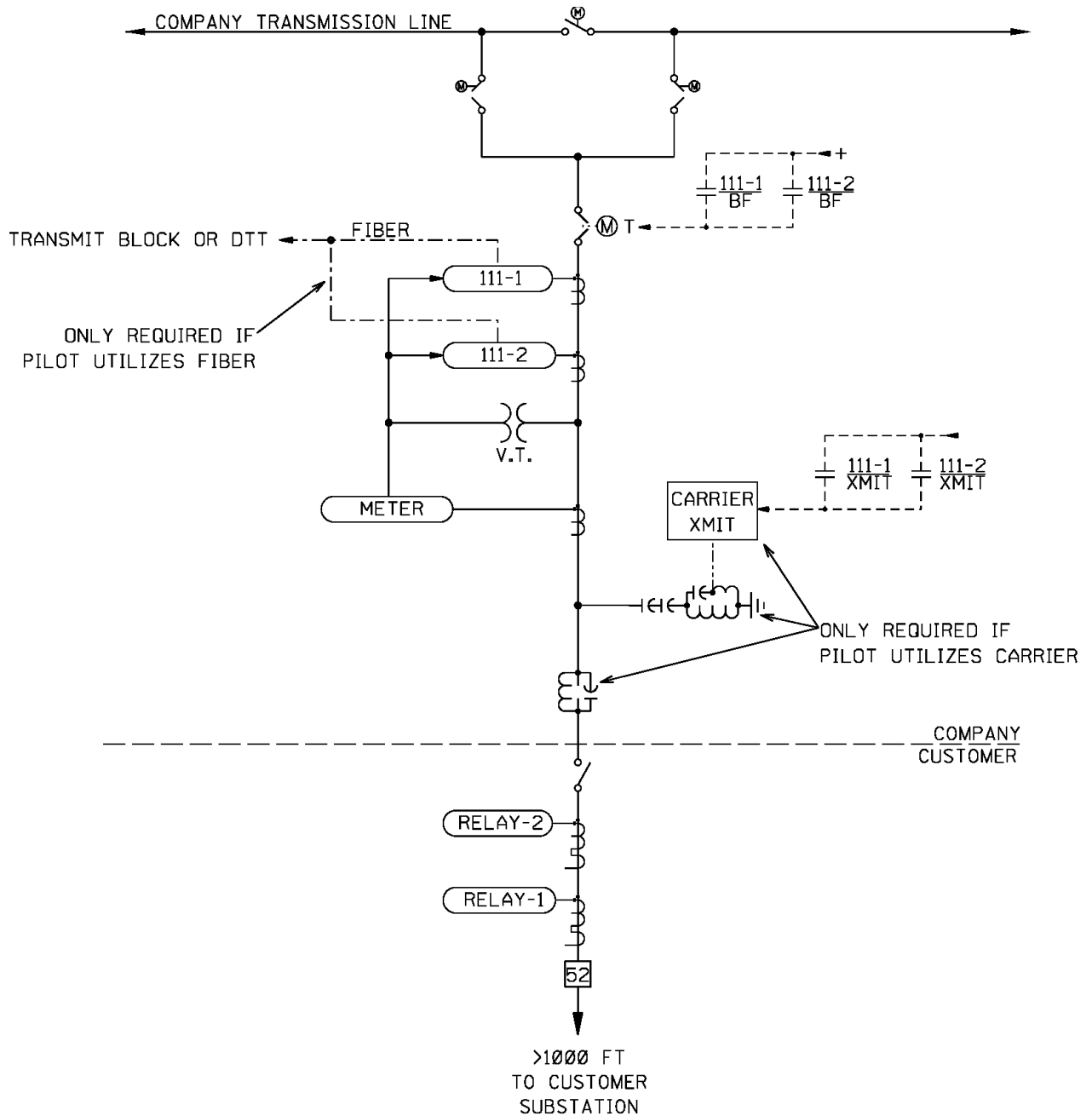

**TRANSMISSION STANDARDS****520-106 Guideline - Facility Interconnection Requirements for Points of Delivery at Transmission Voltages with Retail Customers****INITIAL RELEASE DATE: December 30, 2005****LAST REVISION DATE: November 21, 2023**

6.2.2.4 If pilot relaying exists on Company's line and Company's relaying cannot adequately detect faults to the end of Customer's transmission line extension, Company will install:
(Figure 7)

- Air switches to sectionalize Company's existing line. The switches may be manually operated or motor operated.
- A motor-operated air switch (MOAS) as part of the breaker failure backup protection to isolate Customer's Facilities from Company's Facilities.
- Relaying to provide breaker failure detection, blocking and trip the MOAS.
- Communication equipment to establish a blocking terminal. The blocking terminal is installed to prevent Company's remote terminals from tripping on high speed relaying when a fault occurs on Customer's line extension.
- Wave trap if the pilot relaying utilizes power line carrier.
- Transfer trip equipment.
- Revenue metering equipment (see Section 3.6).



TRANSMISSION STANDARDS

520-106 Guideline - Facility Interconnection Requirements for Points of Delivery at Transmission Voltages with Retail Customers

INITIAL RELEASE DATE: December 30, 2005
 LAST REVISION DATE: November 21, 2023

Figure 7

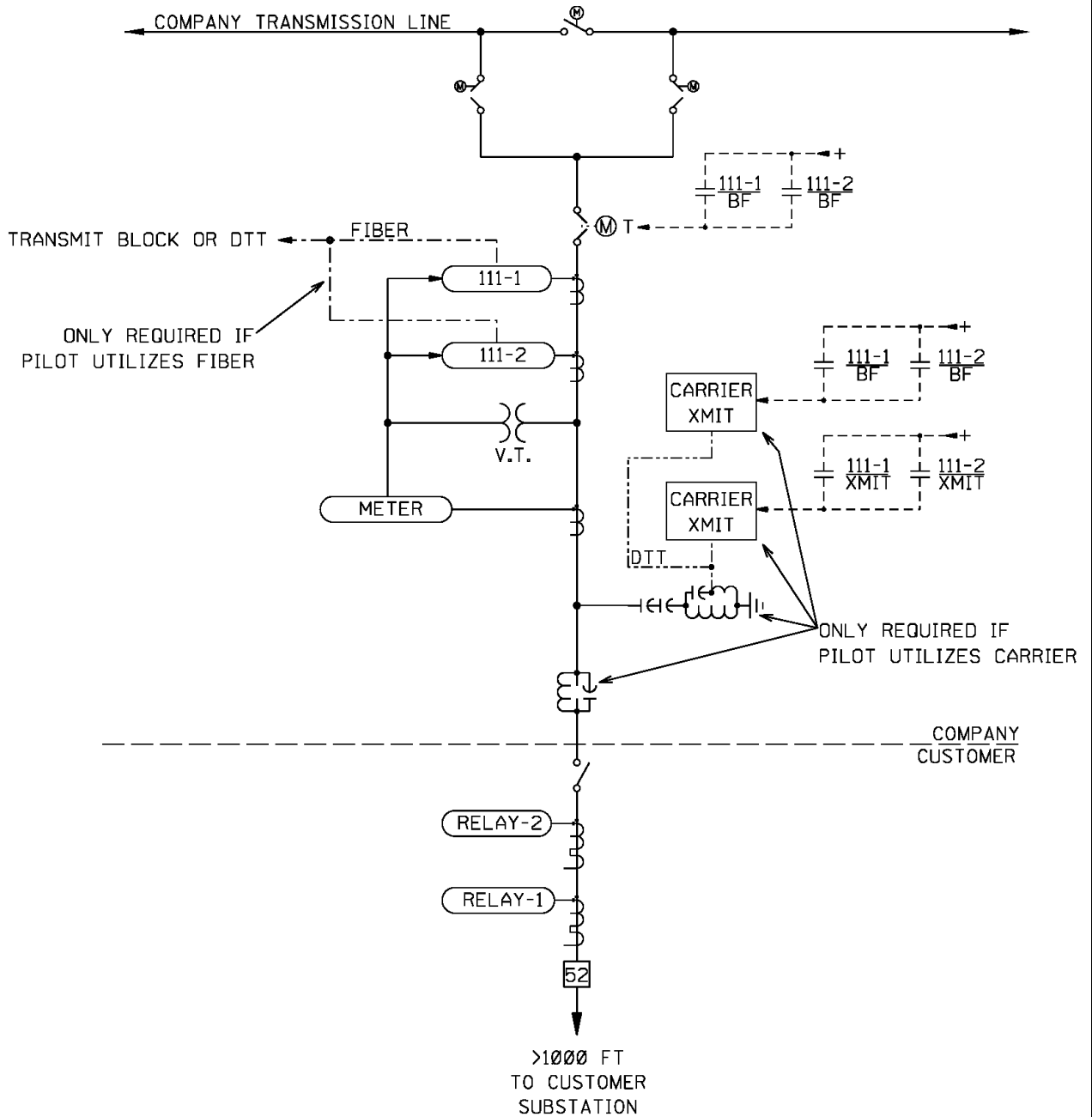

**TRANSMISSION STANDARDS****520-106 Guideline - Facility Interconnection Requirements for Points of Delivery at Transmission Voltages with Retail Customers****INITIAL RELEASE DATE: December 30, 2005****LAST REVISION DATE: November 21, 2023**

7.0 Operational Requirements

7.1 Operating provisions governing the interconnected operations between Company's Facilities and Customer's Facilities when Customer's Facilities will consist of multiple substation transformers connected to multiple transmission lines will be in accordance with this guide, Company procedures, and Regulations. Figure 8 is a typical representation of this type of interconnection.

7.1.1 In the event of a scheduled outage of a Customer substation transformer or a Point of Delivery, if Company's transmission system conditions permit, Company's transmission system dispatcher will permit Customer to transfer all or a part of its load from one Customer substation transformer to a Customer substation transformer connected to another transmission line by paralleling the secondary sides of the transformers, but only if appropriate relaying is in service in Customer's substation to limit the closed transition load transfer time to a maximum of 500 milliseconds. Customer shall not parallel the secondary sides of Customer substation transformers connected to different transmission lines without the approval of Company's transmission system dispatcher. Company will make reasonable efforts to support such request to transfer load. Customer's load-side bus-tie device used to transfer Customer's substation load between transformers connected to different transmission lines shall normally be operated in the open position.

7.1.2 In the event a Customer substation transformer or a POD is de-energized due to an unscheduled event, Customer may transfer all or a part of its load from the de-energized transformer to a Customer substation transformer connected to another transmission line without Company's transmission system dispatcher's prior approval, but only after the Customer opens a circuit breaker or switch to isolate the Customer's substation load from the de-energized transformer. In the event Customer transfers its load in accordance with this paragraph, Customer shall notify Company's transmission system dispatcher of the load transfer as soon as reasonably possible after the transfer takes place.

7.1.3 Company reserves the right to demand Customer, and Customer shall comply with such demand, to remove all or a part of Customer's load from a POD, if Company believes that conditions exist that, in accordance with Good Utility Practice, may endanger persons or property.

7.1.4 If generation will be included as part of Customer's Facilities, additional requirements may apply, and Customer shall contact Company for further review.



TRANSMISSION STANDARDS

520-106 Guideline - Facility Interconnection Requirements for Points of Delivery at Transmission Voltages with Retail Customers

INITIAL RELEASE DATE: December 30, 2005
LAST REVISION DATE: November 21, 2023

Figure 8

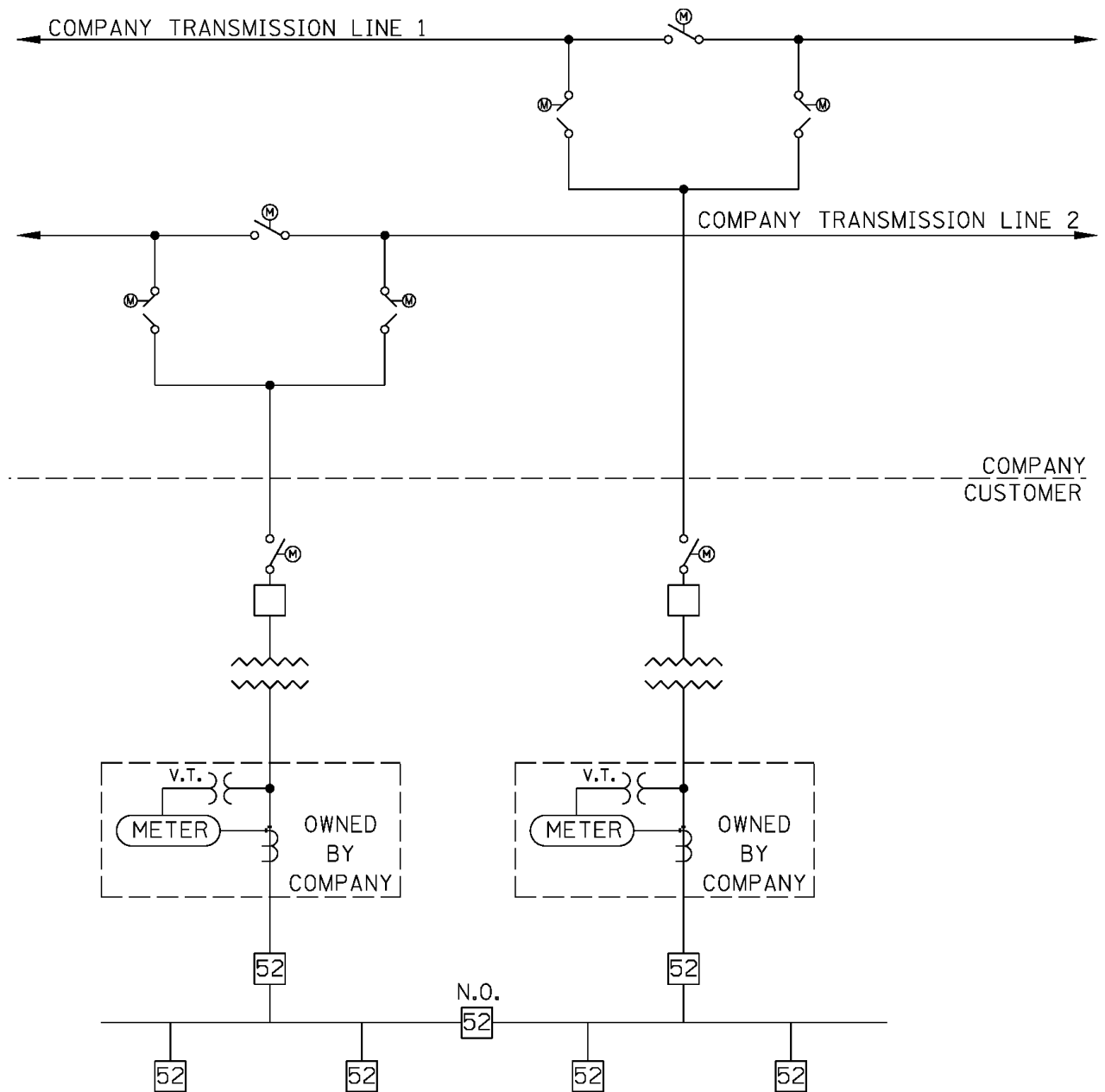

Oncor Proprietary Information



TRANSMISSION STANDARDS

520-106 Guideline - Facility Interconnection Requirements for Points of Delivery at Transmission Voltages with Retail Customers

INITIAL RELEASE DATE: December 30, 2005
LAST REVISION DATE: November 21, 2023

Document History

Change Request Number	Changes Made by	Summary of Changes		
CR-2	Matt Tovar	Minor revision to update language to reflect changes to FAC-001-2 and FAC-002-2 incorporating the 'Qualified Change' definition. Collaborative effort from Transmission Planning, Transmission Services, the RSC team, Transmission Standards, and Legal (Jo Ann Biggs).		
Date	Signature	Name	Title	Department
11/28/2023 2:06 PM PST		Matt Tovar	Manager	Transmission Planning
11/29/2023 3:28 PM PST		Jacob Lewis	Manager	Transmission Services
11/30/2023 10:57 AM PST		Dennis Johnson	Manager II	Transmission Engineering
12/1/2023 8:37 AM PST		Matthew Morrison	Manager	Transmission Standards
12/15/2023 11:52 AM PST		Lance Spross	Director	NERC Compliance

Date	Change Request Number	Changes Made by	Summary of Changes	Approval/Background Information
12/28/2018		James Carroll, Jorge Salinas, Robert Holt	System Protection requirements were updated. The System Protection section is now divided into Customer Equipment Requirements section based on the distance between the Customer Substation and Oncor. The threshold distance is 1000 ft. All figures have been updated, including metering, relaying, and pilot over fiber or carrier.	Approved by stakeholders – 12/28/2018.

Oncor Proprietary Information

Oncor Proprietary Information**TRANSMISSION STANDARDS****520-106 Guideline - Facility Interconnection Requirements for Points of Delivery at Transmission Voltages with Retail Customers****INITIAL RELEASE DATE: December 30, 2005****LAST REVISION DATE: November 21, 2023**

			<p>The term Point of Interconnect (POI) has been replaced with Point of Delivery (POD) throughout the document.</p> <p>Modified the titles in Sections 3.1 and 3.2 to match the wording in NERC Standard FAC-001, Requirements 3.1 and 3.2 and added Section 3.3, Procedures for confirming with those responsible for the reliability of affected systems of new or materially modified transmission facilities are within a Balancing Authority Area's metered boundaries to address NERC Reliability Standard FAC-001, Requirement 3.3 which will become effective on 1-1-19. Revised reference to NERC Reliability Standard FAC-001-1 to read "the latest version of" NERC Reliability Standard FAC-001.</p>	
9/10/2014		T. Preuninger	Revised NERC Reliability Standard to FAC-001-1	
7/28/2010	N/A	B. Dietzman	Guidelines revised to comply with NERC Standard FAC-001-0 - Facility Connection Requirements.	Initial release and officer approval – 7/28/2010.
9/11/2008	F-00102	Libby Smith	Template format change – added "Oncor Proprietary Information"	
9/10/2007		Libby Smith	Template format changes	
12/30/2005		Rafael Garcia	Initial Release The original 500-250 was split into 500-250	

Oncor Proprietary Information

Oncor Proprietary Information



TRANSMISSION STANDARDS

520-106 Guideline - Facility Interconnection Requirements for Points of Delivery at Transmission Voltages with Retail Customers

INITIAL RELEASE DATE: December 30, 2005

LAST REVISION DATE: November 21, 2023

			and 500-251 in order to better define the differences between retail customers and non-retail customers and to provide better guidance on allowable interconnections to Jeff Herring's group who has to deal with the customers up front.	
--	--	--	---	--

Oncor Proprietary Information